

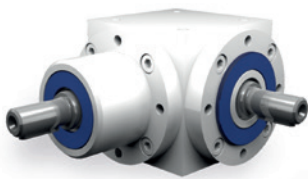

## 6.1 Type overview



### Type V – Standard bevel gearboxes

Gear ratios:  $i = 1:1$  to  $6:1$   
Maximum output torque: 5400 Nm  
9 gearbox sizes with edge lengths of 065 to 350 mm  
Low-backlash construction < 6 angular minutes possible  
Housing made of grey cast iron or steel

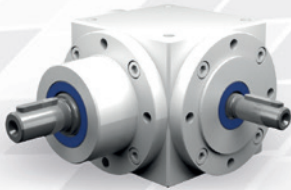

### Type VS – Type V with step-up ratio

Gear ratios:  $i = 1:1.5$  and  $1:2$   
Maximum output torque: 1200 Nm  
6 gearbox sizes with edge lengths of 090 to 260 mm  
Low-backlash construction < 10 angular minutes possible  
Larger shaft diameter ( $N_2$ ), slowly rotating  
Housing made of grey cast iron or steel

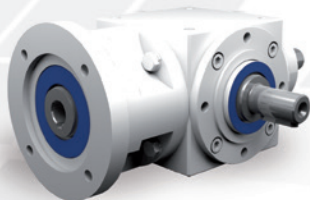

### Type VL – Type V with flange

Gear ratios:  $i = 1:1$  to  $6:1$   
Maximum output torque: 2310 Nm  
8 gearbox sizes with edge lengths of 065 to 260 mm  
Low-backlash construction < 6 angular minutes possible  
Suitable for fitting IEC standard motors  
Drive side with hollow-bored shaft and flange  
Housing made of grey cast iron or steel



### Multi shaft gearbox – with additional shafts

for gear ratios of  $1.5:1$  to  $6:1$  with type V  
for gear ratios of  $1.5:1$  to  $2:1$  with type VS  
with solid shaft or hollow shaft  
up to 6 shaft ends

## 6.2 General construction

A bevel gearbox enables alternatively stepping-down or stepping-up.

The axles intersect in the gearbox in an angle of 90°. The edge length of the housing is reflected in the gearbox size (example: V 120 – housing edge length 120 mm).

### 6.2.1 Tothing

ATEK bevel gearboxes have gear sets with high-quality spiral tothing made of hardened carburised steel. A gear set comprises one bevel pinion (small number of teeth / small diameter) and one bevel gear (large number of teeth / large diameter). Gear sets with spiral tothing offer the advantage of very favourable engagement factors (high meshing ratio). Therefore they are predestined for usage with high loads, combined with optimal running smoothness and high transmission accuracy.

### 6.2.2 Construction types

Due to the modular system, different gearbox construction types can be configured. The construction types vary in

Construction type	No. of gear sets	Additional gears
<b>A0 through E0</b>	1 gear set	
<b>F0 through K0</b>	1 gear set	+ 1 bevel pinion or bevel gear
<b>Branch-off gearbox</b>	1 gear set	+ 2–3 bevel pinions/gears

Table 6.2.2-1

The construction types differ in type and number of the shafts, the rotational direction of the shafts and their support by bearings.

Example of order code: V 090 1:1 A0 - 1.1 -1000 /0000

### 6.2.3 Threaded mounting holes

All 6 sides of the gearboxes are machined and may be used as mounting surfaces. All flanges always have threaded mounting holes. You have the following available ordering options:

Ordering options	Threaded mounting holes are in the housing surfaces on the gearbox side	Threaded mounting holes are in the flanges on the gearbox side
<b>0</b>	-	3, 5, 6
<b>1, 2, 3, 4, 5, 6</b>	1, 2, 4	3, 5, 6
<b>9</b>	1, 2, 4	3, 5, 6

Table 6.2.3-1

The standard version has the order code 9.

Example of order code for mounting option 9: V 090 1:1 A0 - 9.1 -1000 /0000

Other mounting options must be enquired.

### 6.2.4 Installation position

The installation position is defined by the gearbox side directed downwards during operation and will be indicated by the associated numeral. The gearboxes can be used in all installation positions. The technically most favourable and thus recommended installation position is the position in which the shafts are horizontal. These are the installation positions 1 and 2.

Please contact us for consultation if the angle of the gearbox side directed downwards deviates more than 15° from the horizontal position.

For an optimal technical design of the gearboxes, we principally ask to specify the installation position.

Example of order code for installation position 2: V 090 1:1 A0 - 1.2 -1000 /0000

### 6.2.5 Shaft designation – allocation to the gearbox sides

The fast-rotating shaft has the speed  $n_1$  and is identified by  $N_1$ .

The bevel pinion is located on this shaft. The slowly rotating shaft has the speed  $n_2$  and is identified by  $N_2$ .

The bevel gear is located on this shaft.

The gearbox sides are identified by the numerals 1 to 6 (see Figure 4.3.1-1; Gearbox sides)

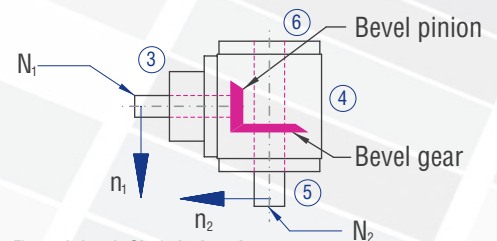

Figure 6.2.5-1; Shaft designations

### 6.2.6 Preferred direction of rotation

If the clockwise (CW) direction of rotation (viewing direction from shaft end face of the fast-rotating shaft towards the gearbox centre) is selected, a 1 to 2 dB(A) lower noise level is generated.

# 6 Bevel gearboxes

## 6.2.7 Efficiency

The achievable efficiency depends on rotational speed, torque, installation position, sealing, and lubricant type.

With gearboxes having only one gear set, an efficiency of 97% can be achieved. With gearboxes having several gear meshings, an efficiency of 94% can be achieved. The efficiencies specified in the tables relate to the permissible nominal load and are guidance values for run-in gearboxes at operating temperature with standard sealing.

## 6.2.8 Lubrication

With the bevel gearboxes, different conditions for the lubrication will arise depending on gearbox size, rotational speed, on-period, temperature, and type of application. The decisive variable is the circumferential speed of the bevel gear. Depending thereon, different oil quantities and viscosities will be used.

These will be defined by ATEK based on your ordering details (rotational speed, on-period, and ambient temperature).

They will be reflected in the type designation. You can find the itemisation in the example: V 090 1:1 C0 - 1.1 -1000 /B0

Here, /B0 means:

	Abbreviation	Explanation	Reference
Letter	B	Oil viscosity 220	Table 6.2.8-1
Numeral	0	no venting	Table 6.2.8-2

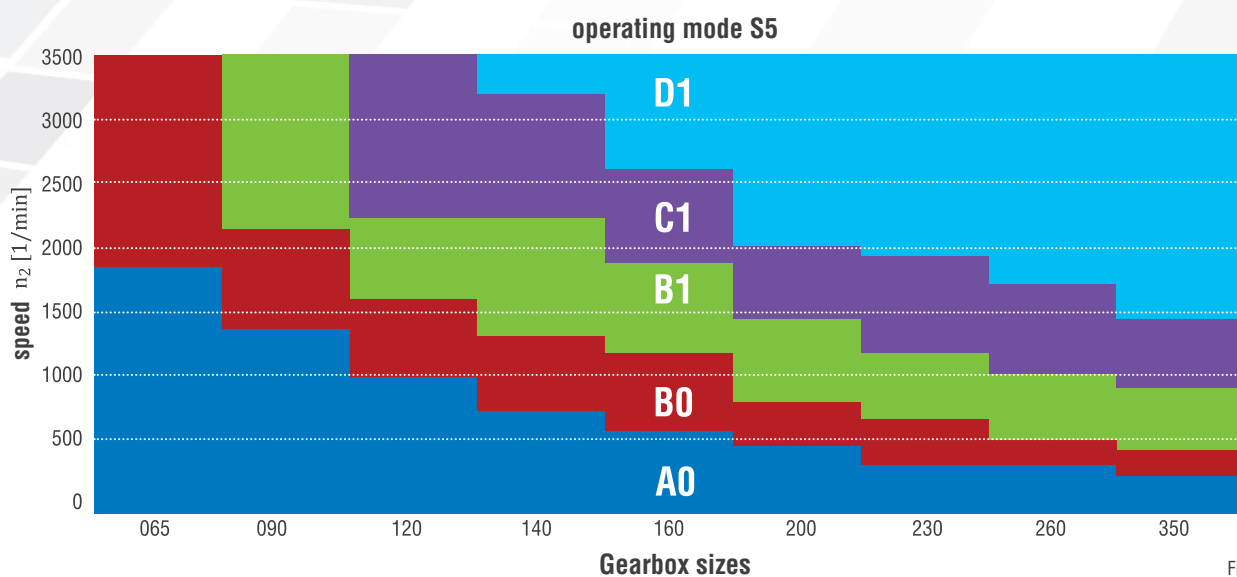
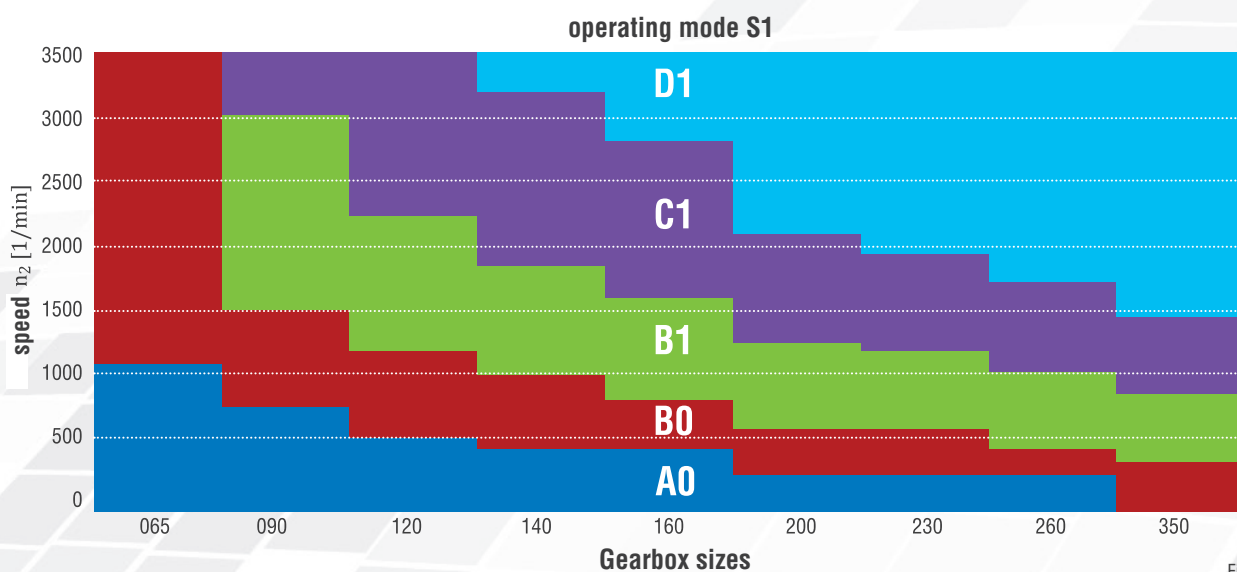

For the abbreviations, refer to the following tables.

## Oil viscosity table

Letter	Viscosity
A	460
B	220
C	68
D	Injection lubrication
F	Fluid grease

Table 6.2.8-1

Depending on the gearbox size, injection lubrication may be necessary in case of high rotational speeds. In case of very low rotational speeds, lubrication by fluid grease is also possible.

Numeral	Vent filter
0	No
1	Yes

Table 6.2.8-2

### 6.2.9 Vent filter

If venting is required (B1 or C1) the gearboxes will be delivered with a vent filter. The vent bores will be equipped with screw plugs for transport. The vent filter will be enclosed as a separate item and must be mounted in the intended position prior to commissioning. An elbow may be required. Please adhere to the operating instructions!

Gearbox size	V065	V090	V120	V140	V160	V200	V230	V350
Pipe thread	G1/4	G1/4	G3/8	G3/8	G1/2	G1/2	G1/2	G1/2

The position of the filter will be specified in the order documents. Please refer to the following table for the position of the filter. The meaning here, for example: /B1-E4 = oil viscosity 220; vent filter on side 4.

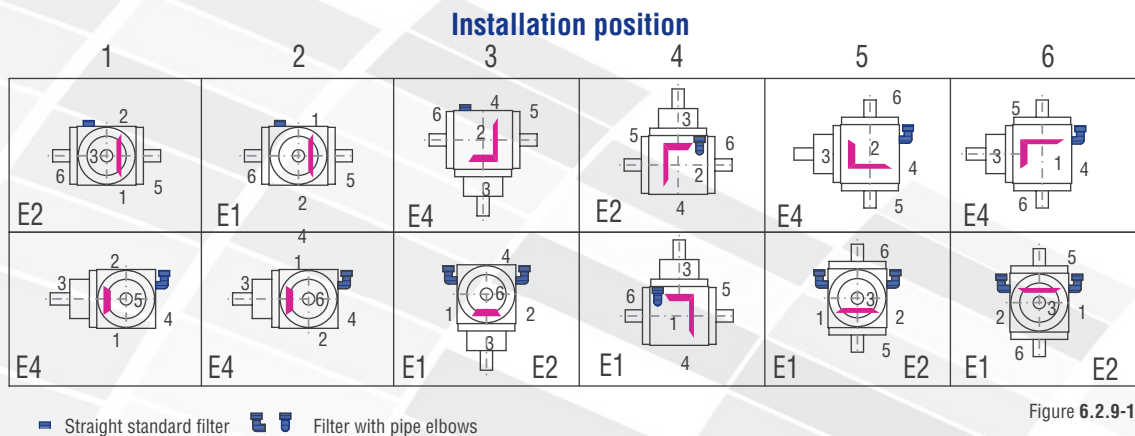

### 6.2.10 Low-backlash construction

For optimal running, the tooth space in the gear set is manufactured larger than the tooth. When the direction of rotation is changed, this results in a rotation angle until the counter-rotating tooth flanks contact each other. This rotation angle is called circumferential backlash.

#### Circumferential backlash, measuring method

The circumferential backlash is measured after the shaft  $N_1$  has been fixed. A force of around 2% of the nominal torque is applied to the shaft  $N_2$  in both rotational directions. A tooth backlash will result between the two final positions. This can be measured as rotation angle and is indicated in minutes of arc [arcmin].

#### Circumferential backlash, type

All ATEK bevel gearboxes can be delivered as low-backlash types. (u.r. – upon request)

Ordering option	Gear set	1:1, 2:1	3:1, 4:1, 5:1, 6:1
/0000	Standard	$\leq 30$ arcmin	$\leq 30$ arcmin
/S2	Standard	$\leq 10$ arcmin	$\leq 10$ arcmin
/S1	Standard	$\leq 6$ arcmin	u.r.
/S0	Special gear set	$\leq 4$ arcmin	u.r.

Abbreviation: u.r. – upon request

Table 6.2.10-1

# 6.3 Type V – Standard bevel gearboxes

## 6.3.1 Features

Gear ratios:  $i = 1:1$  to  $6:1$   
 Maximum output torque: 5400 Nm  
 9 gearbox sizes with edge lengths of 065 to 350 mm  
 Low-backlash construction < 6 angular minutes possible  
 Housing made of grey cast iron or steel

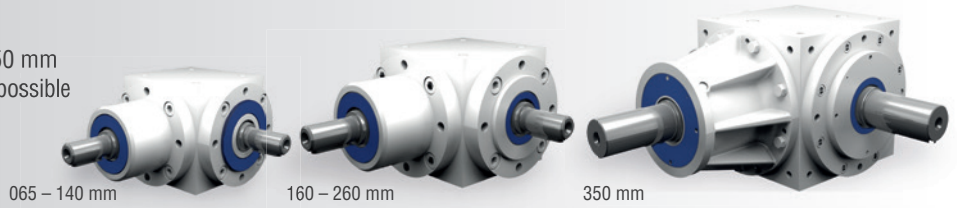

## 6.3.2 Models

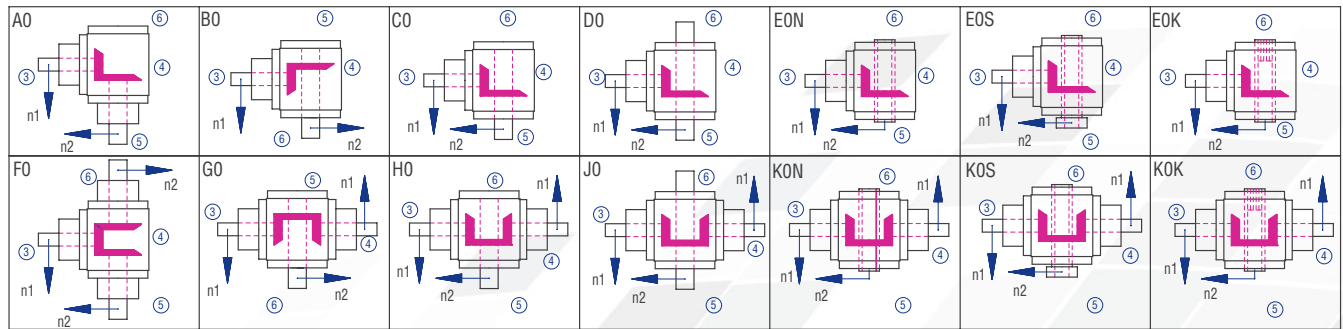

Figure 6.3.2-1; Models

## 6.3.3 Gearbox sides

The example shows the Model C0

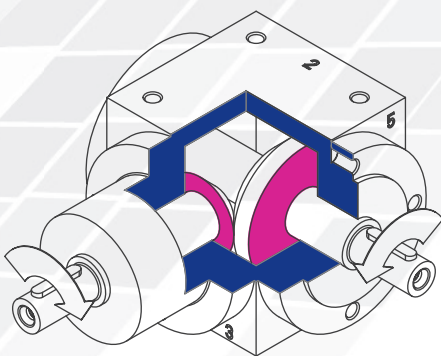

Figure 6.3.3-1; Gearbox sides

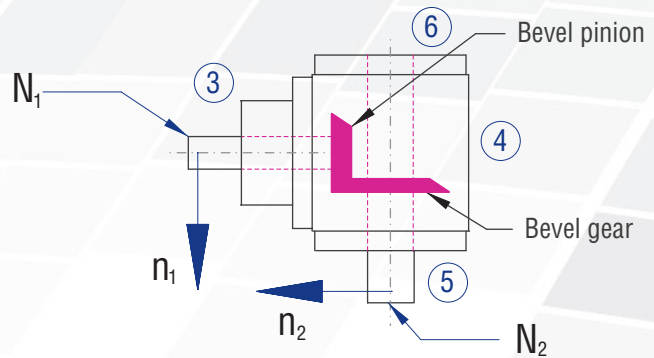

Figure 6.3.3-2; Shaft designations

## 6.3.4 Order code

The order code reflects the customer specifications. Example:

Type	Size	Gear ratio	Model	Fixing side	Installation position	Speed $n_2$	Design
V	065	1:1	C0-	1.	1-	1500	/0000
<b>Description</b>	Housing edge length; Table 6.3.5-1	Table 6.3.5-1	Figure 6.3.2-1; Models	Gearbox side on which fixing is made; Table 6.2.3-1; Figure 4.3.1-1; Gearbox sides	Gearbox side directed downwards; Figure 4.3.1-1; Gearbox sides	Slowly rotating shaft; Table 6.3.5-1	Standard

Table 6.3.4-1

### 6.3.5 Overview of performance data

Bavol  
gearboxes

Size	n <sub>1</sub> [rpm]	1:1			1.5:1			2:1			3:1			4:1			5:1			6:1			
		n <sub>2</sub> [rpm]	P <sub>1N</sub> [kW]	T <sub>2N</sub> [Nm]	n <sub>2</sub> [rpm]	P <sub>1N</sub> [kW]	T <sub>2N</sub> [Nm]	n <sub>2</sub> [rpm]	P <sub>1N</sub> [kW]	T <sub>2N</sub> [Nm]	n <sub>2</sub> [rpm]	P <sub>1N</sub> [kW]	T <sub>2N</sub> [Nm]	n <sub>2</sub> [rpm]	P <sub>1N</sub> [kW]	T <sub>2N</sub> [Nm]	n <sub>2</sub> [rpm]	P <sub>1N</sub> [kW]	T <sub>2N</sub> [Nm]	n <sub>2</sub> [rpm]	P <sub>1N</sub> [kW]	T <sub>2N</sub> [Nm]	
065	3000	3000	3.31	10	2000	2.20	10	1500	1.65	10	1000	1.10	10										
	2400	2400	2.65	10	1600	1.76	10	1200	1.32	10	800	0.88	10										
	1500	1500	1.82	11	1000	1.21	11	750	0.91	11	500	0.61	11										
	1000	1000	1.32	12	667	0.88	12	500	0.66	12	333	0.44	12										
	750	750	1.07	13	500	0.72	13	375	0.54	13	250	0.33	12										
	500	500	0.83	15	333	0.55	15	250	0.41	15	167	0.24	13										
	250	250	0.47	17	167	0.31	17	125	0.23	17	83	0.12	13										
50	50	0.10	18	33	0.07	18	25	0.05	18	17	0.03	14											
090	3000	3000	8.93	27	2000	5.51	25	1500	3.80	23	1000	2.54	23	750	1.90	23	600	1.52	23	500	1.25	23	
	2400	2400	7.41	28	1600	4.59	26	1200	3.17	24	800	2.12	24	600	1.65	25	480	1.32	25	400	1.09	25	
	1500	1500	5.29	32	1000	3.20	29	750	2.23	27	500	1.49	27	375	1.12	27	300	0.89	27	250	0.74	27	
	1000	1000	3.75	34	667	2.35	32	500	1.71	31	333	1.14	31	250	0.85	31	200	0.68	31	167	0.53	29	
	750	750	3.06	37	500	1.93	35	375	1.32	32	250	0.88	32	188	0.66	32	150	0.53	32	125	0.40	29	
	500	500	2.20	40	333	1.36	37	250	0.94	34	167	0.63	34	125	0.47	34	100	0.37	34	83	0.27	29	
	250	250	1.21	44	167	0.74	40	125	0.50	36	83	0.33	36	63	0.25	36	50	0.20	36	42	0.14	30	
50	50	0.28	50	33	0.16	45	25	0.10	37	17	0.07	37	13	0.05	37	10	0.04	37	8	0.03	33		
120	3000	3000	21.82	66	2000	13.45	61	1500	9.26	56	1000	6.39	58	750	4.96	60	600	3.97	60	500	2.95	54	
	2400	2400	18.52	70	1600	11.46	65	1200	8.07	61	800	5.56	63	600	4.43	67	480	3.44	64	400	2.53	57	
	1500	1500	13.56	82	1000	8.60	78	750	6.03	73	500	4.08	74	375	3.06	74	300	2.38	72	250	1.75	64	
	1000	1000	10.14	92	667	6.32	86	500	4.46	81	333	3.01	82	250	2.18	79	200	1.76	80	167	1.22	66	
	750	750	8.51	103	500	5.18	94	375	3.55	86	250	2.40	87	188	1.69	82	150	1.42	86	125	0.94	68	
	500	500	6.34	115	333	3.85	100	250	2.54	92	167	1.66	90	125	1.16	84	100	0.98	89	83	0.63	69	
	250	250	3.39	123	167	1.99	100	125	1.35	98	83	0.87	95	63	0.60	87	50	0.51	92	42	0.33	71	
50	50	0.72	130	33	0.41	100	25	0.29	107	17	0.21	110	13	0.12	90	10	0.10	95	8	0.06	66		
140	3000	3000	39.68	120	2000	24.91	113	1500	16.53	100	1000	12.12	110	750	8.51	103	600	6.61	100	500	5.18	94	
	2400	2400	37.04	140	1600	22.22	126	1200	14.68	111	800	11.46	130	600	7.34	111	480	5.56	105	400	4.58	104	
	1500	1500	26.78	162	1000	17.08	155	750	11.41	138	500	8.05	146	375	4.96	120	300	3.80	115	250	2.95	107	
	1000	1000	20.28	184	667	12.87	175	500	8.38	152	333	5.87	160	250	3.75	136	200	2.73	124	167	2.06	112	
	750	750	16.20	196	500	10.47	190	375	6.86	166	250	4.60	167	188	3.06	148	150	2.15	130	125	1.61	117	
	500	500	11.46	208	333	7.34	200	250	4.96	180	167	3.20	174	125	2.12	154	100	1.50	136	83	1.09	119	
	250	250	5.92	215	167	3.76	204	125	2.62	190	83	1.62	177	63	1.12	162	50	0.79	143	42	0.56	121	
50	50	1.21	220	33	0.76	210	25	0.55	200	17	0.34	180	13	0.23	170	10	0.17	150	8	0.11	120		
160	3000			2000	40.78	185	1500	28.11	170	1000	20.94	190	750	14.88	180	600	11.90	180	500	7.09	129		
	2400	2400	57.67	218	1600	36.15	205	1200	25.53	193	800	17.81	202	600	13.23	200	480	10.48	198	400	5.98	136	
	1500	1500	42.99	260	1000	27.78	252	750	20.25	245	500	12.68	230	375	9.09	220	300	7.11	215	250	3.95	143	
	1000	1000	31.96	290	667	20.59	280	500	14.88	270	333	8.99	245	250	6.61	240	200	4.96	225	167	3.01	164	
	750	750	25.63	310	500	16.26	295	375	11.57	280	250	6.89	250	188	5.17	250	150	3.97	240	125	2.43	176	
	500	500	18.19	330	333	11.56	315	250	8.27	300	167	4.79	260	125	3.58	260	100	2.76	250	83	1.72	187	
	250	250	9.64	350	167	6.07	330	125	4.41	320	83	2.56	280	63	1.86	270	50	1.49	270	42	0.92	199	
50	50	2.09	380	33	1.29	355	25	0.98	355	17	0.57	305	13	0.39	280	10	0.32	290	8	0.18	197		
200	3000			2000	72.75	330	1500	51.25	310	1000	46.29	420	750	28.93	350	600	19.84	300	500	11.45	208		
	2400			1600	63.49	360	1200	45.24	342	800	39.24	445	600	26.45	400	480	17.99	340	400	9.60	218		
	1500	1500	74.40	450	1000	48.17	437	750	35.13	425	500	28.38	515	375	18.81	455	300	12.57	380	250	6.54	237	
	1000	1000	56.21	510	667	37.13	505	500	27.56	500	333	20.37	555	250	13.36	485	200	9.26	420	167	4.74	258	
	750	750	45.88	555	500	30.31	550	375	22.52	540	250	15.98	580	188	10.54	510	150	7.27	440	125	3.98	289	
	500	500	34.17	620	333	22.57	615	250	16.81	610	167	11.04	600	125	7.23	525	100	5.18	470	83	2.79	304	
	250	250	19.56	710	167	12.70	690	125	9.37	680	83	5.76	630	63	3.79	550	50	2.78	505	42	1.44	311	
50	50	4.13	750	33	2.73	750	25	2.07	750	17	1.29	690	13	0.80	580	10	0.58	525	8	0.28	306		
230	3000			2000	99.20	450	1500	87.63	530	1000	44.09	400	750	36.37	440	600	33.73	510	500	20.17	366		
	2400			1600	91.35	518	1200	80.02	605	800	39.68	450	600	32.74	495	480	29.10	550	400	18.08	410		
	1500	1500	87.63	530	1000	72.20	655	750	59.11	715	500	29.76	540	375	24.80	600	300	21.00	635	250	13.50	490	
	1000	1000	71.65	650	667	56.21	765	500	45.19	820	333	23.33	635	250	18.60	675	200	15.76	715	167	9.92	540	
	750	750	60.76	735	500	45.47	825	375	36.79	890	250	19.29	700	188	15.19	735	150	12.73	770	125	7.78	565	
	500	500	45.19	820	333	33.79	920	250	26.73	970	167	14.07	765	125	10.95	795	100	9.15	830	83	5.42	590	
	250	250	26.73	970	167	20.57	1120	125	16.88	1225	83	7.58	825	63	5.99	870	50	5.07	920	42	2.82	610	
50	50	7.00	1270	33	4.89	1330	25	3.66	1330	17	1.63	870	13	1.35	980	10	1.09	990	8	0.57	625		
260	3000			2000	189.58	860	1500	133.92	810	1000	85.97	780	750	57.87	700	600	46.29	700	500	27.27	495		
	2400			1600	158.72	900	1200	112.43	850	800	72.39	821	600	51.58	780	480	40.21	760	400	23.12	524		
	1500	1500	157.07	950	1000	104.71	950	750	78.53	950	500	49.60	900	375	37.20	900	300	29.10	880	250	16.36	594	
	1000	1000	115.73	1050	667	77.19	1050	500	57.87	1050	333	36.34	990	250	28.93	1050	200	21.82	990	167	12.93	702	
	750	750	96.72	1170	500	64.48	1170	375	48.36	1170	250	28.93	1050	188	22.73	1100	150	18.19	1100	125	10.91	792	
	500	500	72.75	1320	333	47.72	1300	250	35.27	1280	167	20.43	1110	125	16.26	1180	100	13.23	1200	83	8.06	878	
	250	250	42.44	1540	167	27.43	1490	125	20.12	1460	83	11.16											

## 6.3.6 Type V 065 – Standard bevel gearboxes

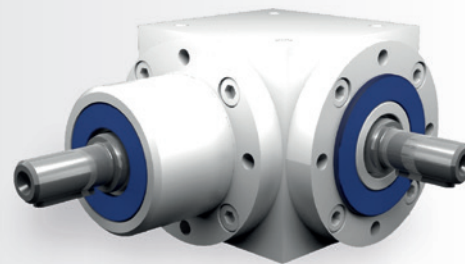

### Characteristics

Characteristic	Standard	Option
<b>Toothing</b>	Spiral toothed bevel gear set	See chapter 6.2.1
<b>Gear ratio</b>	1:1 to 3:1	
<b>Housing / Flanges</b>	Grey cast iron; steel	
<b>Threaded mounting hole</b>	On all housing surfaces without flange and on all flanges.	See chapter 6.2.3
<b>Shaft</b>	Material 1 C45, shaft ends greased Fit with ISO 6 tolerance with parallel keyway: according to DIN 6885 Sheet 1	See chapter 4.6.2
<b>Hollow shaft</b>	Material 1 C45, shafts greased Fit with ISO 7 tolerance with parallel keyway: according to DIN 6885 Sheet 1	See chapter 4.6.3
<b>Radial shaft seal ring</b>	NBR, form A	See chapter 4.8
<b>Ambient temperature</b>	-10°C to +90°C. The values of the performance tables are valid for +20°C	See chapter 4.9.3
<b>Circumferential backlash</b>	< 30 arcmin	See chapter 6.2.10
<b>Protection class</b>	IP 54	See chapter 4.5
<b>Corrosion protection</b>	Prime coat; layer thickness > 40 µm	See chapter 4.4.1
<b>Bearing life L10h</b>	more than 15,000h	See chapter 4.9.1
<b>Oil change intervals</b>	Not required if the oil temperature is kept < 90°C The lifetime of the bearings can be increased by the factor 1.5 if the oil is changed after the first 500 service hours and then every 5000 service hours.	See chapter 6.2.8
<b>Lubricant</b>	Synthetic lubricants	See chapter 6.2.8

## Performance data

n <sub>1</sub> [rpm]	1:1			1.5:1			2:1			3:1			4:1			5:1			6:1			
	n <sub>2</sub> [rpm]	P <sub>1N</sub> [kW]	T <sub>2N</sub> [Nm]	n <sub>2</sub> [rpm]	P <sub>1N</sub> [kW]	T <sub>2N</sub> [Nm]	n <sub>2</sub> [rpm]	P <sub>1N</sub> [kW]	T <sub>2N</sub> [Nm]	n <sub>2</sub> [rpm]	P <sub>1N</sub> [kW]	T <sub>2N</sub> [Nm]	n <sub>2</sub> [rpm]	P <sub>1N</sub> [kW]	T <sub>2N</sub> [Nm]	n <sub>2</sub> [rpm]	P <sub>1N</sub> [kW]	T <sub>2N</sub> [Nm]	n <sub>2</sub> [rpm]	P <sub>1N</sub> [kW]	T <sub>2N</sub> [Nm]	
3000	3000	3.31	10	2000	2.20	10	1500	1.65	10	1000	1.10	10										
2400	2400	2.65	10	1600	1.76	10	1200	1.32	10	800	0.88	10										
1500	1500	1.82	11	1000	1.21	11	750	0.91	11	500	0.61	11										
1000	1000	1.32	12	667	0.88	12	500	0.66	12	333	0.44	12										
750	750	1.07	13	500	0.72	13	375	0.54	13	250	0.33	12										
500	500	0.83	15	333	0.55	15	250	0.41	15	167	0.24	13										
250	250	0.47	17	167	0.31	17	125	0.23	17	83	0.12	13										
50	50	0.10	18	33	0.07	18	25	0.05	18	17	0.03	14										
P <sub>1Nt</sub> [kW]		1.6			1.6			1.6			1.6											
T <sub>2max</sub> [Nm]		25			25			25			23											

## Permissible radial force F<sub>r1</sub> and axial force F<sub>a1</sub> on shaft N<sub>1</sub>

n <sub>1</sub> [rpm]	3000		1000		500		250		100		50	
T <sub>2</sub> [Nm]	F <sub>r</sub> [N]	F <sub>a</sub> [N]	F <sub>r</sub> [N]	F <sub>a</sub> [N]	F <sub>r</sub> [N]	F <sub>a</sub> [N]	F <sub>r</sub> [N]	F <sub>a</sub> [N]	F <sub>r</sub> [N]	F <sub>a</sub> [N]	F <sub>r</sub> [N]	F <sub>a</sub> [N]
< 12	180	90	250	125	300	150	350	175	450	225	550	275
> 12	150	75	210	105	250	125	290	145	380	190	460	230

## Permissible radial force F<sub>r2</sub> and axial force F<sub>a2</sub> on shaft N<sub>2</sub>

n <sub>2</sub> [rpm]	3000		1000		500		250		100		50	
T <sub>2</sub> [Nm]	F <sub>r</sub> [N]	F <sub>a</sub> [N]	F <sub>r</sub> [N]	F <sub>a</sub> [N]	F <sub>r</sub> [N]	F <sub>a</sub> [N]	F <sub>r</sub> [N]	F <sub>a</sub> [N]	F <sub>r</sub> [N]	F <sub>a</sub> [N]	F <sub>r</sub> [N]	F <sub>a</sub> [N]
< 12	300	150	400	200	500	250	650	325	750	375	900	450
> 12	250	125	330	165	420	210	540	270	630	315	750	375

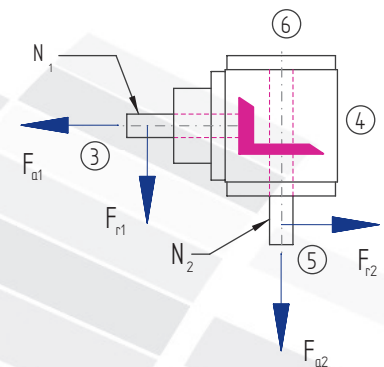

## Inertia moments/mass

Inertia moment J<sub>1</sub> related to the fast-rotating shaft (N<sub>1</sub>)

Model	Inertia moment [kgcm <sup>2</sup> ]							Mass [kg]
	1:1	1.5:1	2:1	3:1	4:1	5:1	6:1	
A0	0.38880	0.24060	0.18390	0.10360				2.3
B0	0.42310	0.31110	0.23300	0.10010				2.2
C0	0.42310	0.31110	0.23300	0.10010				2.2
D0	0.43300	0.31550	0.23550	0.10120				2.3
E0N	0.47540	0.36340	0.28530	0.15240				2.1
E0S	0.60120	0.48920	0.41110	0.27820				2.1
F0	0.58320	0.32700	0.23250	0.12520				2.7
G0	0.61750	0.46530	0.36830	0.18210				2.6
H0	0.61750	0.46530	0.36830	0.18210				2.6
J0	0.62740	0.46970	0.37080	0.18320				2.7
K0N	0.66980	0.51760	0.42060	0.23440				2.5
K0S	0.79560	0.64340	0.54640	0.36020				2.5

# 6.3.6 Type V 065 – Standard bevel gearboxes

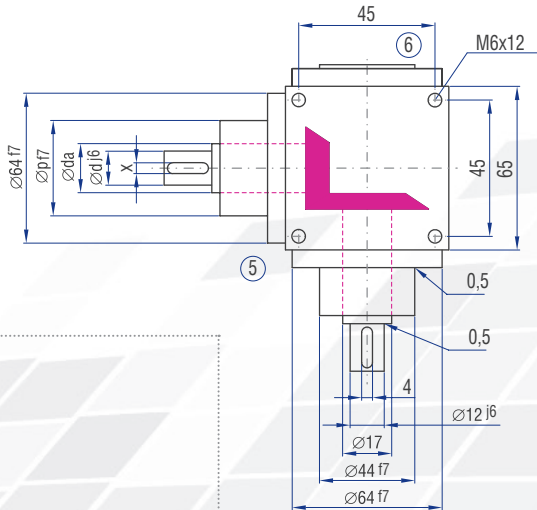
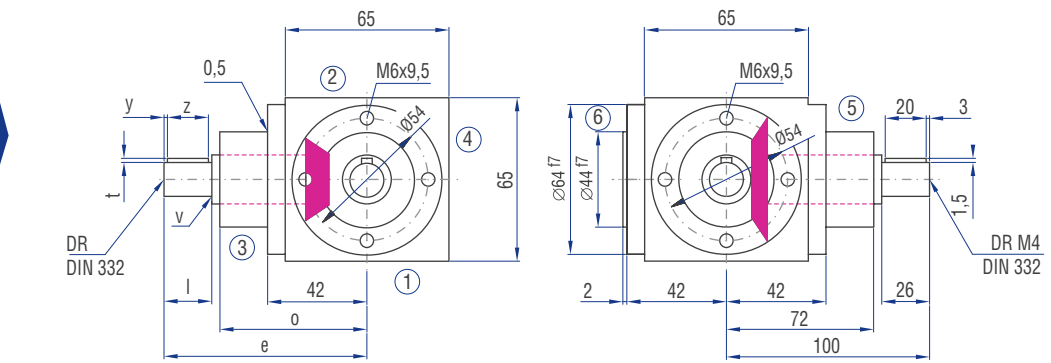
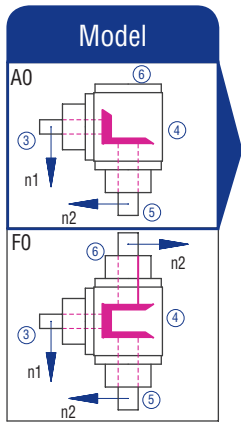

	Gear ratio						
	1:1	1.5:1	2:1	3:1	4:1	5:1	6:1
d [mm]	12	12	12	12			
da [mm]	17	17	17	17			
l [mm]	26	26	26	26			
v [mm]	0.5	0.5	0.5	0.5			
x [mm]	4	4	4	4			
y [mm]	3	3	3	3			
z [mm]	20	20	20	20			
t [mm]	1.5	1.5	1.5	1.5			
e [mm]	100	100	100	100			
o [mm]	72	72	72	72			
p [mm]	44	44	44	44			
DR M	4	4	4	4			

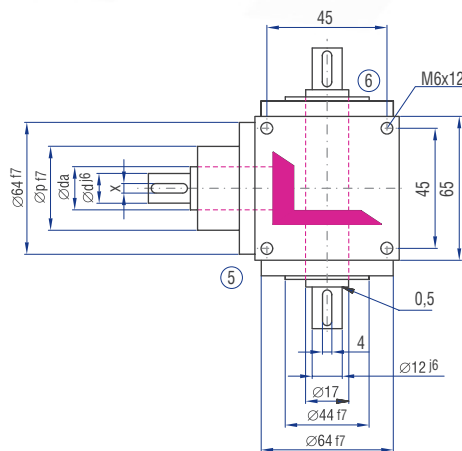
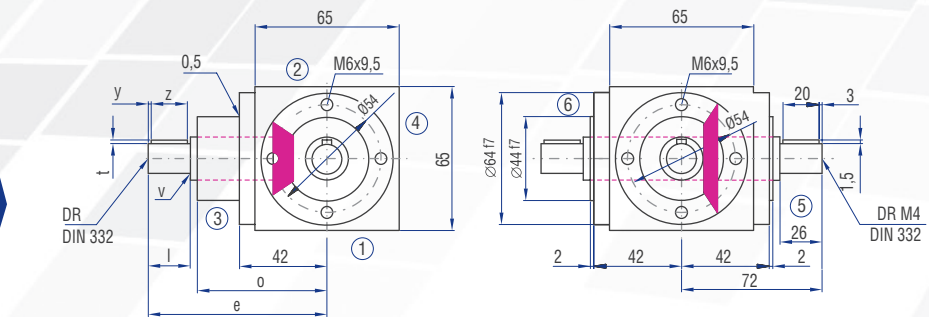
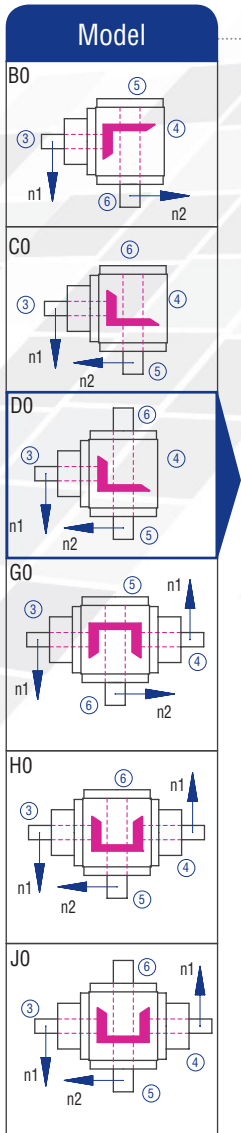

## Implementation vv

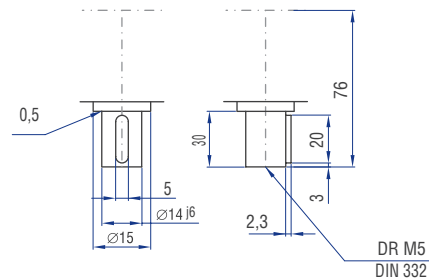

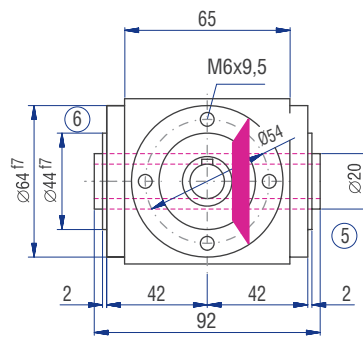
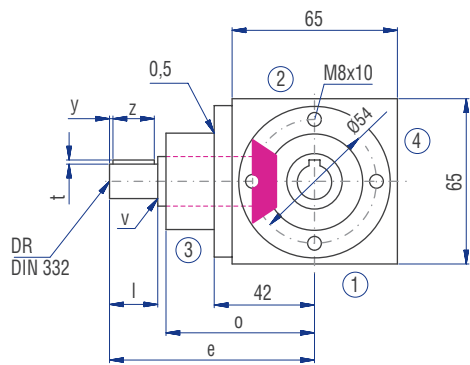

Implementation

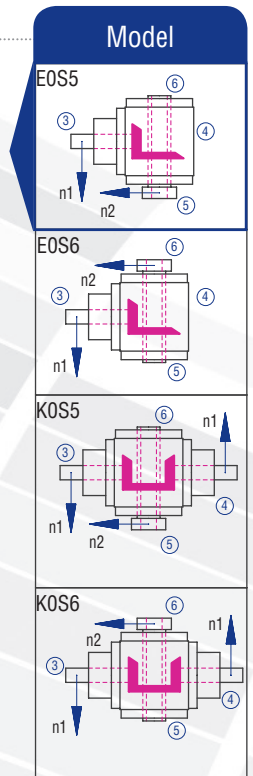
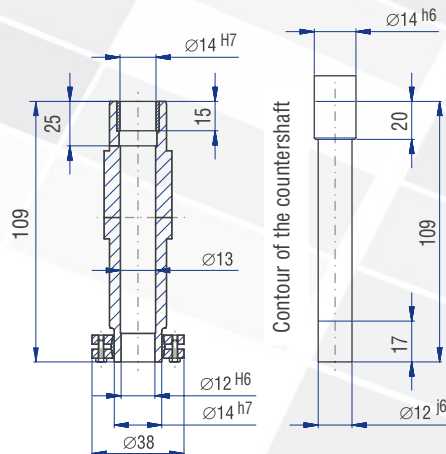
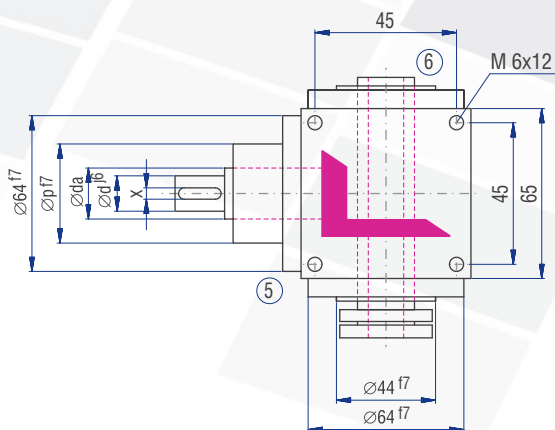
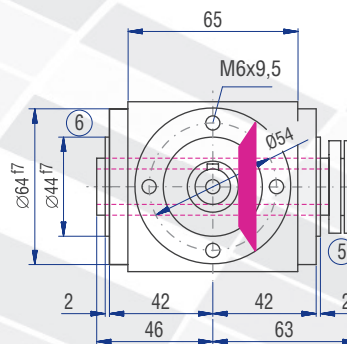
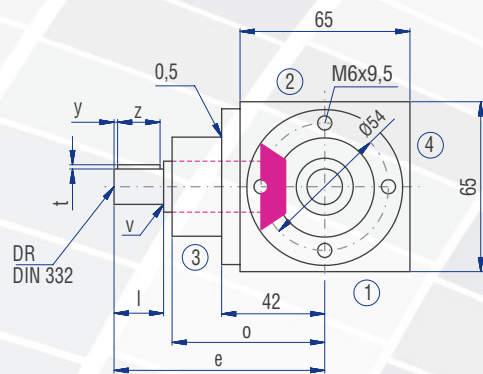
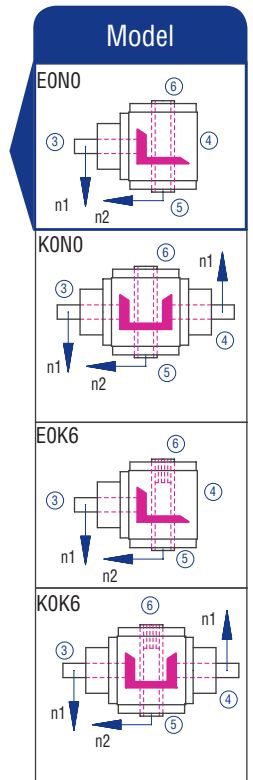
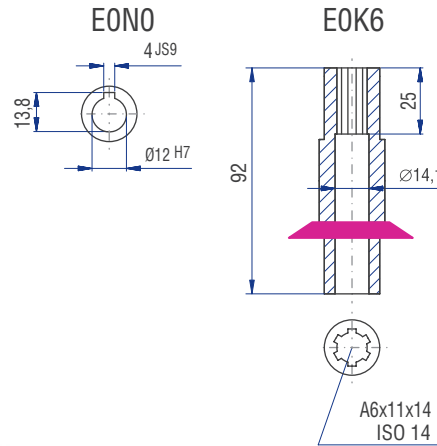
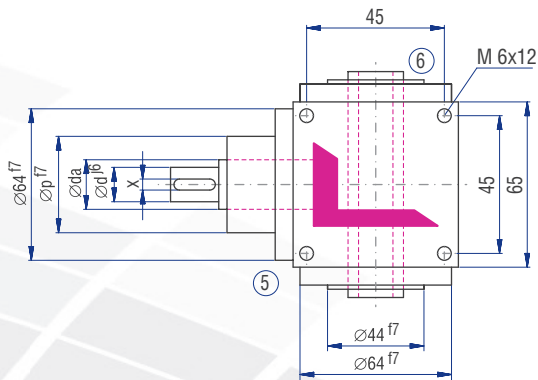

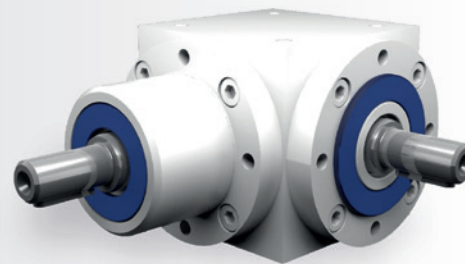

### Characteristics

Characteristic	Standard	Option
<b>Toothing</b>	Spiral toothed bevel gear set	See chapter 6.2.1
<b>Gear ratio</b>	1:1 to 6:1	
<b>Housing / Flanges</b>	Grey cast iron; steel	
<b>Threaded mounting hole</b>	On all housing surfaces without flange and on all flanges.	See chapter 6.2.3
<b>Shaft</b>	Material 1 C45, shaft ends greased Fit with ISO 6 tolerance with parallel keyway: according to DIN 6885 Sheet 1	See chapter 4.6.2
<b>Hollow shaft</b>	Material 1 C45, shafts greased Fit with ISO 7 tolerance with parallel keyway: according to DIN 6885 Sheet 1	See chapter 4.6.3
<b>Radial shaft seal ring</b>	NBR, form A	See chapter 4.8
<b>Ambient temperature</b>	-10°C to +90°C. The values of the performance tables are valid for +20°C	See chapter 4.9.3
<b>Circumferential backlash</b>	< 30 arcmin	See chapter 6.2.10
<b>Protection class</b>	IP 54	See chapter 4.5
<b>Corrosion protection</b>	Prime coat; layer thickness > 40 µm	See chapter 4.4.1
<b>Bearing life L10h</b>	more than 15,000h	See chapter 4.9.1
<b>Oil change intervals</b>	Not required if the oil temperature is kept < 90°C The lifetime of the bearings can be increased by the factor 1.5 if the oil is changed after the first 500 service hours and then every 5000 service hours.	See chapter 6.2.8
<b>Lubricant</b>	Synthetic lubricants	See chapter 6.2.8

## Performance data

n <sub>1</sub> [rpm]	1:1			1.5:1			2:1			3:1			4:1			5:1			6:1		
	n <sub>2</sub> [rpm]	P <sub>1N</sub> [kW]	T <sub>2N</sub> [Nm]	n <sub>2</sub> [rpm]	P <sub>1N</sub> [kW]	T <sub>2N</sub> [Nm]	n <sub>2</sub> [rpm]	P <sub>1N</sub> [kW]	T <sub>2N</sub> [Nm]	n <sub>2</sub> [rpm]	P <sub>1N</sub> [kW]	T <sub>2N</sub> [Nm]	n <sub>2</sub> [rpm]	P <sub>1N</sub> [kW]	T <sub>2N</sub> [Nm]	n <sub>2</sub> [rpm]	P <sub>1N</sub> [kW]	T <sub>2N</sub> [Nm]	n <sub>2</sub> [rpm]	P <sub>1N</sub> [kW]	T <sub>2N</sub> [Nm]
3000	3000	8.93	27	2000	5.51	25	1500	3.80	23	1000	2.54	23	750	1.90	23	600	1.52	23	500	1.25	23
2400	2400	7.41	28	1600	4.59	26	1200	3.17	24	800	2.12	24	600	1.65	25	480	1.32	25	400	1.09	25
1500	1500	5.29	32	1000	3.20	29	750	2.23	27	500	1.49	27	375	1.12	27	300	0.89	27	250	0.74	27
1000	1000	3.75	34	667	2.35	32	500	1.71	31	333	1.14	31	250	0.85	31	200	0.68	31	167	0.53	29
750	750	3.06	37	500	1.93	35	375	1.32	32	250	0.88	32	188	0.66	32	150	0.53	32	125	0.40	29
500	500	2.20	40	333	1.36	37	250	0.94	34	167	0.63	34	125	0.47	34	100	0.37	34	83	0.27	29
250	250	1.21	44	167	0.74	40	125	0.50	36	83	0.33	36	63	0.25	36	50	0.20	36	42	0.14	30
50	50	0.28	50	33	0.16	45	25	0.10	37	17	0.07	37	13	0.05	37	10	0.04	37	8	0.03	33
P <sub>1Nt</sub> [kW]	3.8			3.8			3.8			3.8			3.8			3.8			3.8		
T <sub>2max</sub> [Nm]	105			80			80			70			70			60			50		

### Permissible radial force F<sub>r1</sub> and axial force F<sub>a1</sub> on shaft N<sub>1</sub>

n <sub>1</sub> [rpm]	3000		1000		500		250		100		50	
T <sub>2</sub> [Nm]	F <sub>r</sub> [N]	F <sub>a</sub> [N]	F <sub>r</sub> [N]	F <sub>a</sub> [N]	F <sub>r</sub> [N]	F <sub>a</sub> [N]	F <sub>r</sub> [N]	F <sub>a</sub> [N]	F <sub>r</sub> [N]	F <sub>a</sub> [N]	F <sub>r</sub> [N]	F <sub>a</sub> [N]
< 30	300	150	400	200	470	235	580	290	700	350	800	400
> 30	250	125	330	165	390	195	490	245	590	295	670	335

### Permissible radial force F<sub>r2</sub> and axial force F<sub>a2</sub> on shaft N<sub>2</sub>

n <sub>2</sub> [rpm]	3000		1000		500		250		100		50	
T <sub>2</sub> [Nm]	F <sub>r</sub> [N]	F <sub>a</sub> [N]	F <sub>r</sub> [N]	F <sub>a</sub> [N]	F <sub>r</sub> [N]	F <sub>a</sub> [N]	F <sub>r</sub> [N]	F <sub>a</sub> [N]	F <sub>r</sub> [N]	F <sub>a</sub> [N]	F <sub>r</sub> [N]	F <sub>a</sub> [N]
< 30	500	250	660	330	800	400	950	475	1250	625	1500	750
> 30	420	210	550	275	670	335	790	395	1040	520	1250	625

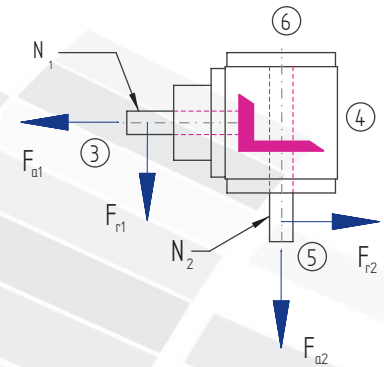

### Inertia moments/mass

Inertia moment J<sub>1</sub> related to the fast-rotating shaft (N<sub>1</sub>)

Model	Inertia moment [kgcm <sup>2</sup> ]							Mass [kg]
	1:1	1.5:1	2:1	3:1	4:1	5:1	6:1	
A0	2.55900	1.48220	1.14370	0.88840	0.36310	0.32480	0.30620	5.1
B0	3.35430	2.18330	1.36520	1.04650	0.46070	0.39330	0.35020	5.4
C0	3.35430	2.18330	1.36520	1.04650	0.46070	0.39330	0.35020	5.4
D0	3.38270	2.19590	1.37230	1.04960	0.46250	0.39450	0.35100	5.5
E0N	3.25070	2.13720	1.33930	1.03500	0.45420	0.38920	0.34730	5.0
E0S	3.92130	2.43530	1.50690	1.10950	0.49610	0.41600	0.36600	5.2
F0	3.83850	2.05080	1.46360	1.03050	0.44300	0.37600	0.34180	6.3
G0	4.63380	3.09680	2.18900	1.79270	0.74380	0.66690	0.62090	6.9
H0	4.63380	3.09680	2.18900	1.79270	0.74380	0.66690	0.62090	6.9
J0	4.66220	3.10940	2.19610	1.79580	0.74560	0.66810	0.62170	7.0
K0N	4.53020	3.05070	2.16310	1.78120	0.73730	0.66280	0.61800	6.5
K0S	5.20080	3.34880	2.33070	1.85570	0.77920	0.68960	0.63670	6.7

# 6.3.7 Type V 090 – Standard bevel gearboxes

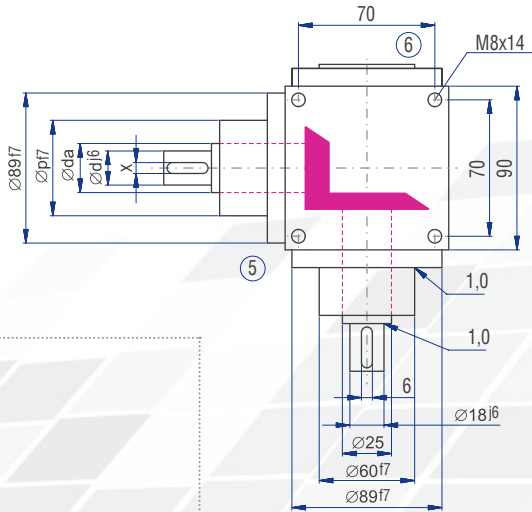
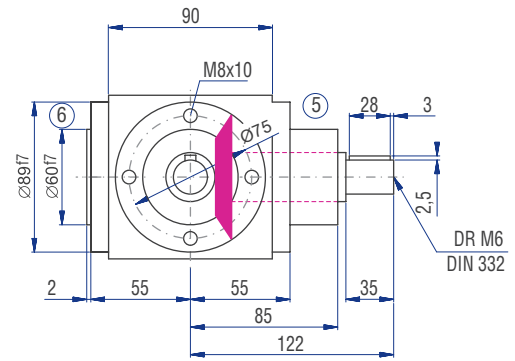
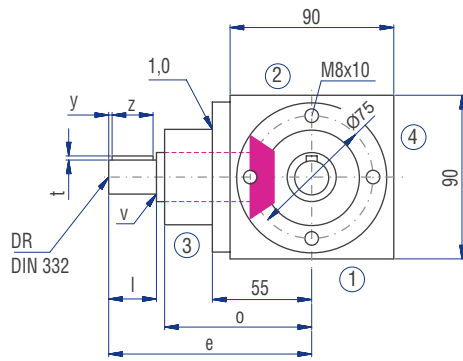
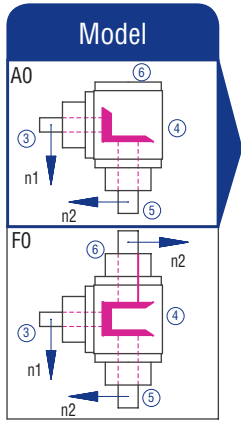

	Gear ratio						
	1:1	1.5:1	2:1	3:1	4:1	5:1	6:1
d [mm]	18	18	18	12	12	12	12
da [mm]	25	25	25	20	20	20	20
l [mm]	35	35	35	35	35	35	35
v [mm]	1	1	1	0.5	0.5	0.5	0.5
x [mm]	6	6	6	4	4	4	4
y [mm]	3	3	3	3	3	3	3
z [mm]	28	28	28	28	28	28	28
t [mm]	2.5	2.5	2.5	1.5	1.5	1.5	1.5
e [mm]	122	122	122	122	132	132	132
o [mm]	85	85	85	85	95	95	95
p [mm]	60	60	60	60	60	60	60
DR M	6	6	6	4	4	4	4

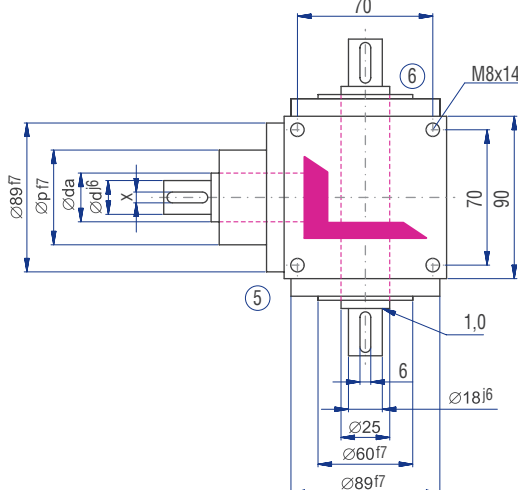
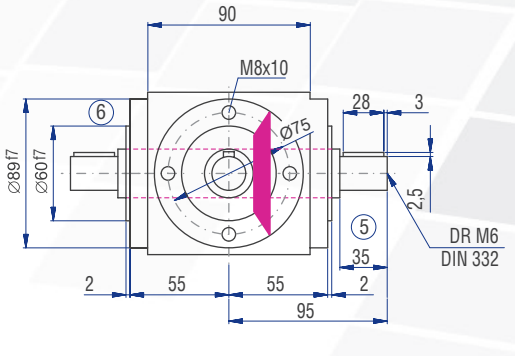
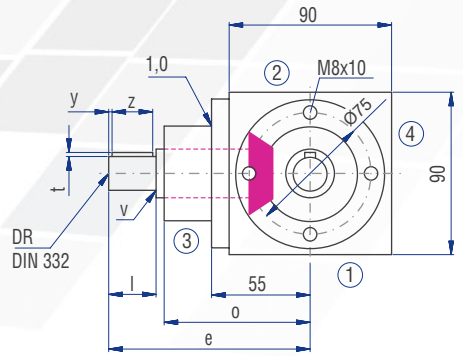
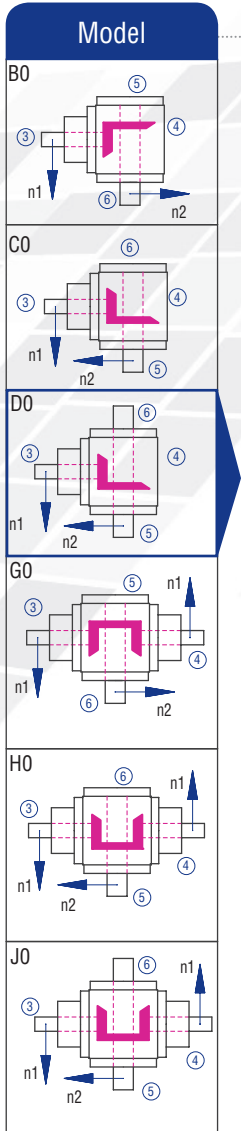

## Implementation VV

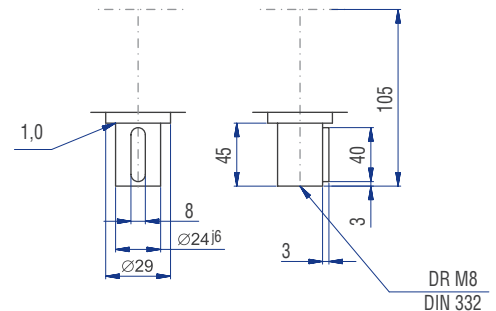

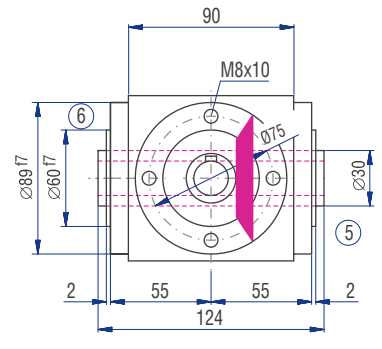
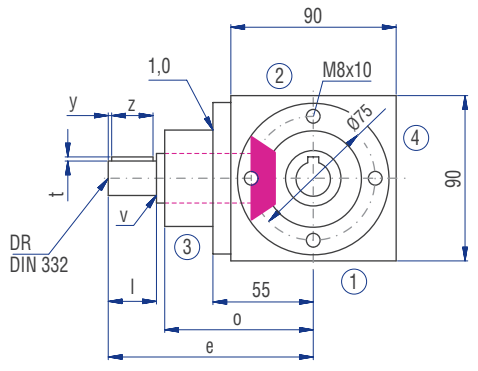

Implementation

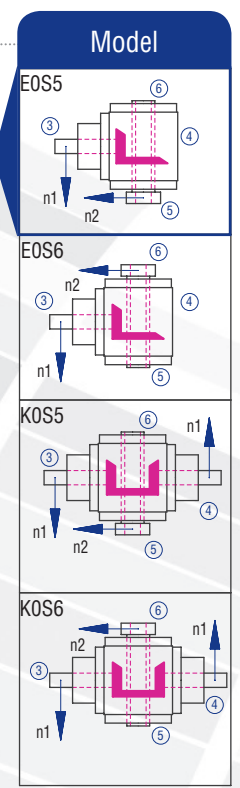
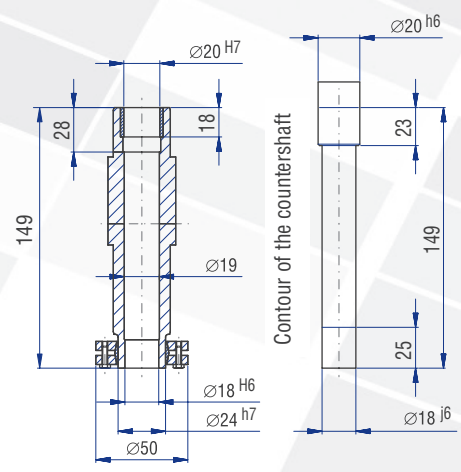
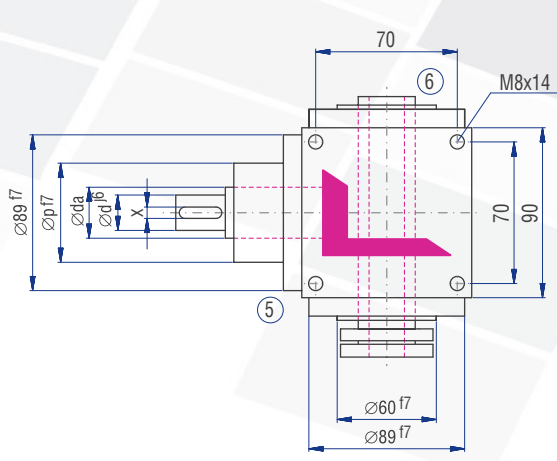
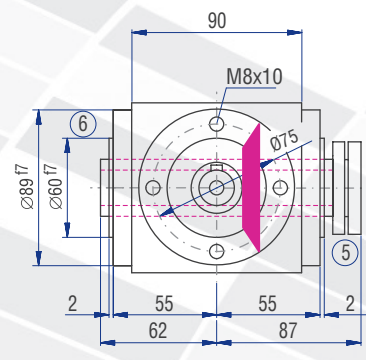
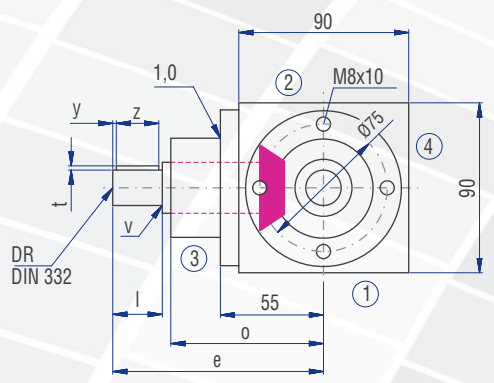
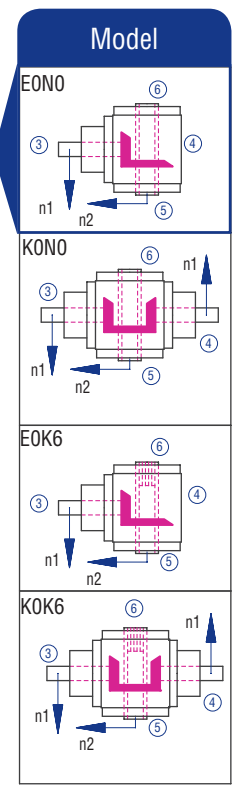
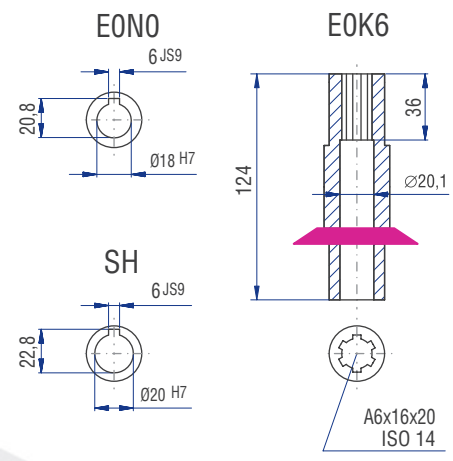
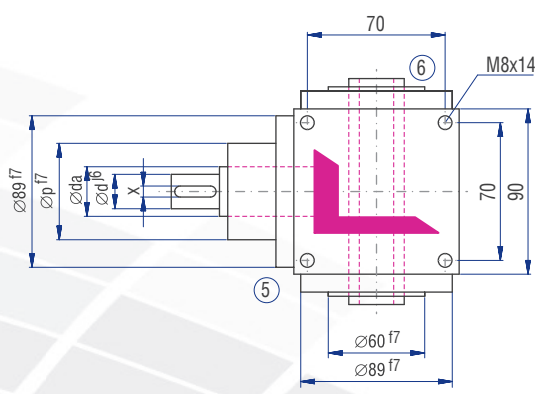

## 6.3.8 Type V 120 – Standard bevel gearboxes

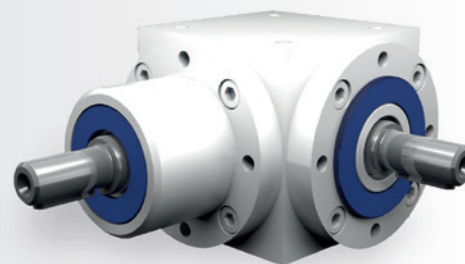

### Characteristics

Characteristic	Standard	Option
<b>Toothing</b>	Spiral toothed bevel gear set	See chapter 6.2.1
<b>Gear ratio</b>	1:1 to 6:1	
<b>Housing / Flanges</b>	Grey cast iron; steel	
<b>Threaded mounting hole</b>	On all housing surfaces without flange and on all flanges.	See chapter 6.2.3
<b>Shaft</b>	Material 1 C45, shaft ends greased Fit with ISO 6 tolerance with parallel keyway: according to DIN 6885 Sheet 1	See chapter 4.6.2
<b>Hollow shaft</b>	Material 1 C45, shafts greased Fit with ISO 7 tolerance with parallel keyway: according to DIN 6885 Sheet 1	See chapter 4.6.3
<b>Radial shaft seal ring</b>	NBR, form A	See chapter 4.8
<b>Ambient temperature</b>	-10°C to +90°C. The values of the performance tables are valid for +20°C	See chapter 4.9.3
<b>Circumferential backlash</b>	< 30 arcmin	See chapter 6.2.10
<b>Protection class</b>	IP 54	See chapter 4.5
<b>Corrosion protection</b>	Prime coat; layer thickness > 40 µm	See chapter 4.4.1
<b>Bearing life L10h</b>	more than 15,000h	See chapter 4.9.1
<b>Oil change intervals</b>	Not required if the oil temperature is kept < 90°C The lifetime of the bearings can be increased by the factor 1.5 if the oil is changed after the first 500 service hours and then every 5000 service hours.	See chapter 6.2.8
<b>Lubricant</b>	Synthetic lubricants	See chapter 6.2.8

## Performance data

$n_1$ [rpm]	1:1			1.5:1			2:1			3:1			4:1			5:1			6:1		
	$n_2$ [rpm]	$P_{1N}$ [kW]	$T_{2N}$ [Nm]	$n_2$ [rpm]	$P_{1N}$ [kW]	$T_{2N}$ [Nm]	$n_2$ [rpm]	$P_{1N}$ [kW]	$T_{2N}$ [Nm]	$n_2$ [rpm]	$P_{1N}$ [kW]	$T_{2N}$ [Nm]	$n_2$ [rpm]	$P_{1N}$ [kW]	$T_{2N}$ [Nm]	$n_2$ [rpm]	$P_{1N}$ [kW]	$T_{2N}$ [Nm]	$n_2$ [rpm]	$P_{1N}$ [kW]	$T_{2N}$ [Nm]
3000	3000	21.82	66	2000	13.45	61	1500	9.26	56	1000	6.39	58	750	4.96	60	600	3.97	60	500	2.95	54
2400	2400	18.52	70	1600	11.46	65	1200	8.07	61	800	5.56	63	600	4.43	67	480	3.44	65	400	2.53	57
1500	1500	13.56	82	1000	8.60	78	750	6.03	73	500	4.08	74	375	3.06	74	300	2.38	72	250	1.75	64
1000	1000	10.14	92	667	6.32	86	500	4.46	81	333	3.01	82	250	2.18	79	200	1.76	80	167	1.22	66
750	750	8.51	103	500	5.18	94	375	3.55	86	250	2.40	87	188	1.69	82	150	1.42	86	125	0.94	68
500	500	6.34	115	333	3.85	100	250	2.54	92	167	1.66	90	125	1.16	84	100	0.98	89	83	0.63	69
250	250	3.39	123	167	1.99	100	125	1.35	98	83	0.87	95	63	0.60	87	50	0.51	92	42	0.33	71
50	50	0.72	130	33	0.41	100	25	0.29	107	17	0.21	110	13	0.12	90	10	0.10	95	8	0.06	66
$P_{1Nt}$ [kW]	6.2			6.2			6.2			6.2			6.2			6.2			6.2		
$T_{2max}$ [Nm]	220			169			169			155			155			140			120		

## Permissible radial force $F_{r1}$ and axial force $F_{a1}$ on shaft $N_1$

$n_1$ [rpm]	3000		1000		500		250		100		50	
$T_2$ [Nm]	$F_r$ [N]	$F_a$ [N]	$F_r$ [N]	$F_a$ [N]	$F_r$ [N]	$F_a$ [N]	$F_r$ [N]	$F_a$ [N]	$F_r$ [N]	$F_a$ [N]	$F_r$ [N]	$F_a$ [N]
< 80	470	235	620	310	720	360	900	450	1150	575	1400	700
> 80	390	195	520	260	600	300	750	375	960	480	1170	585

## Permissible radial force $F_{r2}$ and axial force $F_{a2}$ on shaft $N_2$

$n_2$ [rpm]	3000		1000		500		250		100		50	
$T_2$ [Nm]	$F_r$ [N]	$F_a$ [N]	$F_r$ [N]	$F_a$ [N]	$F_r$ [N]	$F_a$ [N]	$F_r$ [N]	$F_a$ [N]	$F_r$ [N]	$F_a$ [N]	$F_r$ [N]	$F_a$ [N]
< 80	750	375	1000	500	1250	625	1500	750	1900	950	2200	1100
> 80	630	315	830	415	1040	520	1250	625	1580	790	1830	915

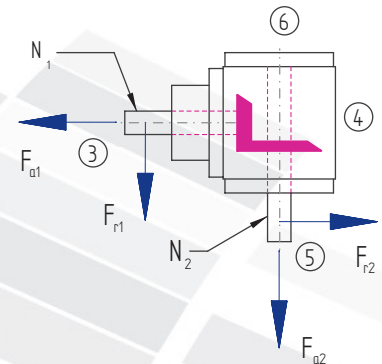

## Inertia moments/mass

Inertia moment  $J_1$  related to the fast-rotating shaft ( $N_1$ )

Model	Inertia moment [kgcm <sup>2</sup> ]							Mass [kg]
	1:1	1.5:1	2:1	3:1	4:1	5:1	6:1	
A0	10.4976	4.84090	3.64650	2.31590	1.21640	0.75160	0.67660	12.6
B0	15.3022	7.44410	4.97470	3.01230	1.67290	1.05930	0.89820	12.3
C0	15.3022	7.44410	4.97470	3.01230	1.67290	1.05930	0.89820	12.3
D0	15.5996	7.57620	5.04900	3.04530	1.69150	1.07120	0.90650	12.5
E0N	15.1939	7.39590	4.94760	3.00030	1.66610	1.05500	0.89520	12.0
E0S	16.9812	8.19030	5.39440	3.19880	1.77780	1.12650	0.94490	12.3
F0	15.7464	7.17370	4.95870	2.89910	1.54440	0.96150	0.82240	15.0
G0	20.5510	9.95220	7.30900	4.74500	2.56120	1.60090	1.42900	14.7
H0	20.5510	9.95220	7.30900	4.74500	2.56120	1.60090	1.42900	14.7
J0	20.8484	10.0843	7.38330	4.77800	2.57980	1.61280	1.43730	14.9
K0N	20.4427	9.90400	7.28190	4.73300	2.55440	1.59660	1.42600	14.4
K0S	22.2300	10.6984	7.72870	4.93150	2.66610	1.66810	1.47570	14.7

# 6.3.8 Type V 120 – Standard bevel gearboxes

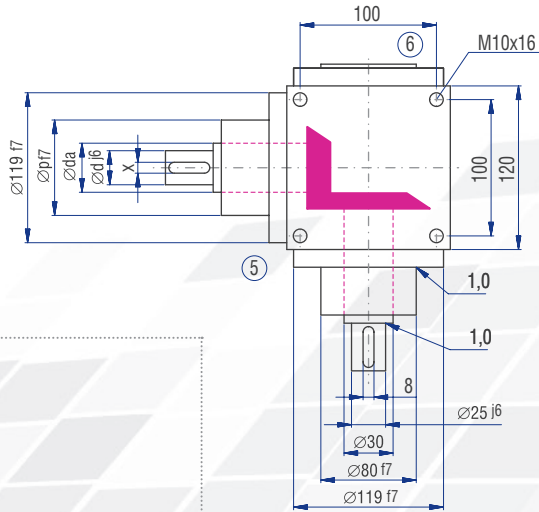
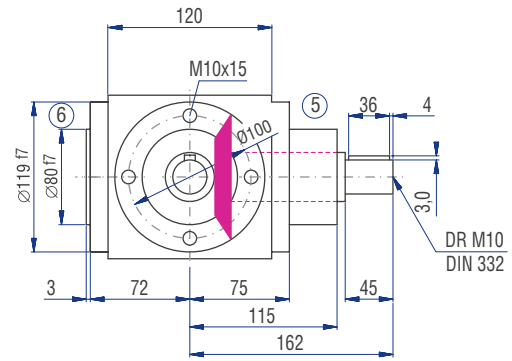
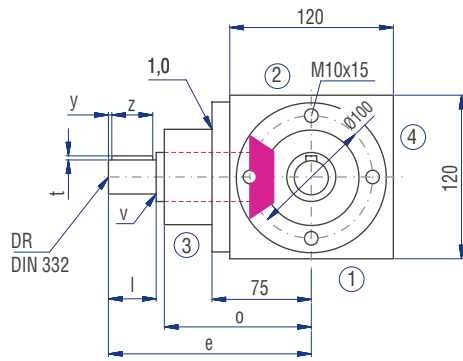
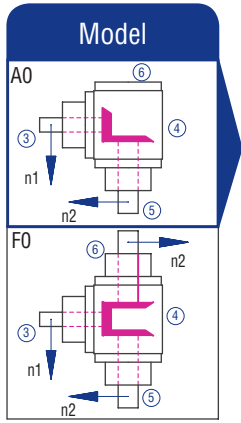

	Gear ratio						
	1:1	1.5:1	2:1	3:1	4:1	5:1	6:1
<b>d [mm]</b>	25	25	25	20	20	15	15
<b>da [mm]</b>	30	30	30	25	25	20	20
<b>l [mm]</b>	45	45	45	45	45	35	35
<b>v [mm]</b>	1	1	1	1	1	0.5	0.5
<b>x [mm]</b>	8	8	8	6	6	5	5
<b>y [mm]</b>	4	4	4	4	4	4	4
<b>z [mm]</b>	36	36	36	36	36	28	28
<b>t [mm]</b>	3	3	3	2.5	2.5	2	2
<b>e [mm]</b>	162	162	162	162	172	162	162
<b>o [mm]</b>	115	115	115	115	125	125	125
<b>p [mm]</b>	80	80	80	80	80	70	70
<b>DR M</b>	10	10	10	6	6	5	5

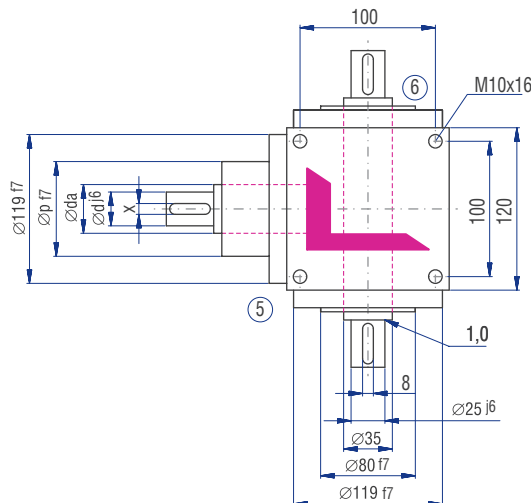
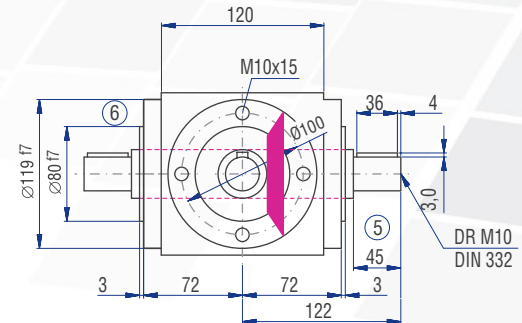
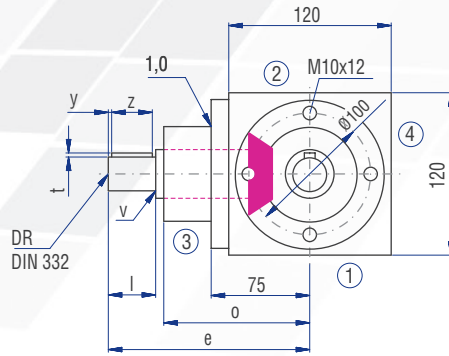
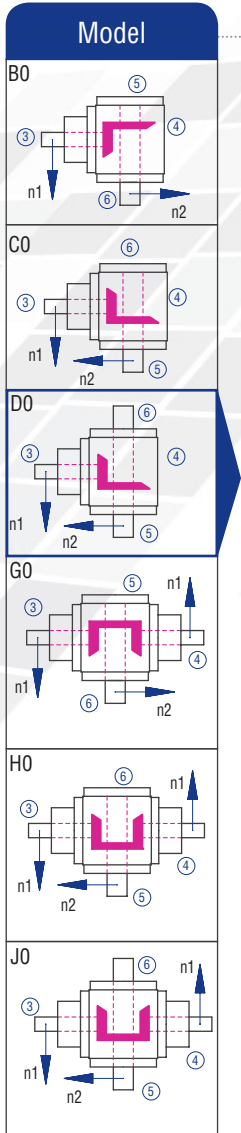

## Implementation VV

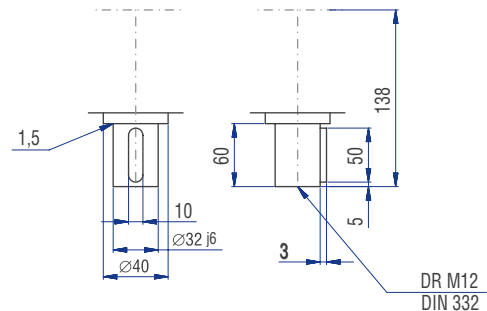

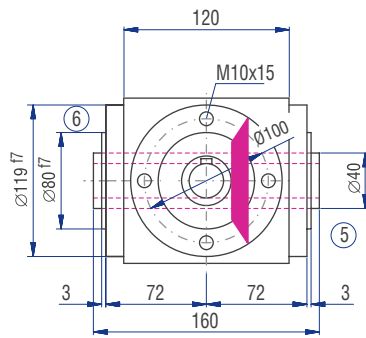
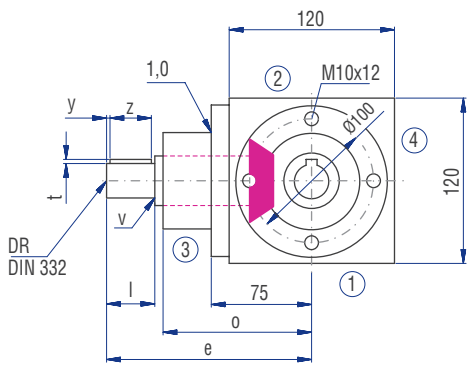

### Implementation

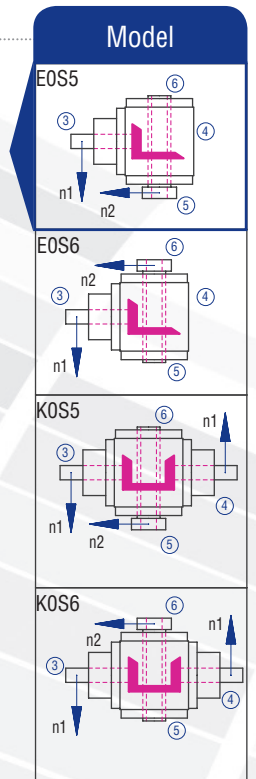
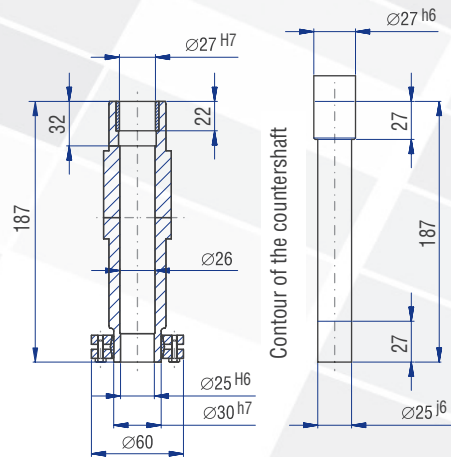
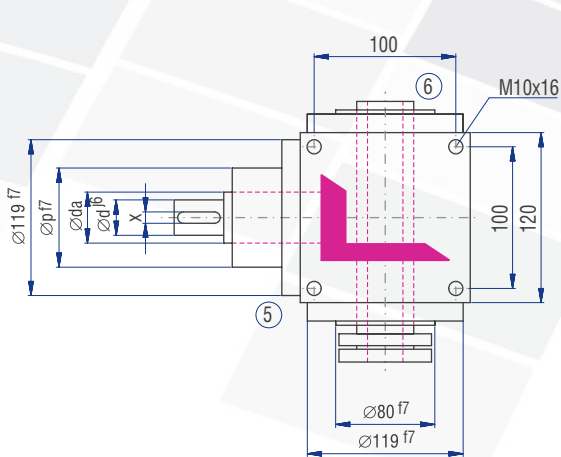
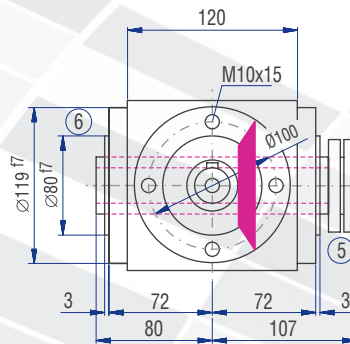
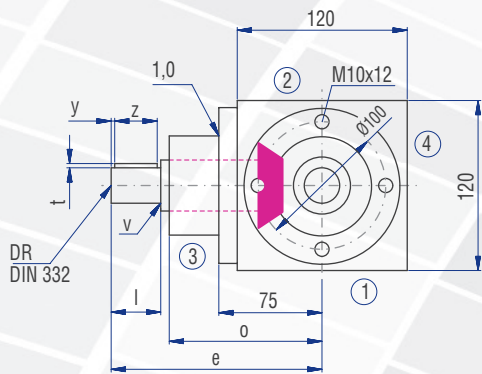
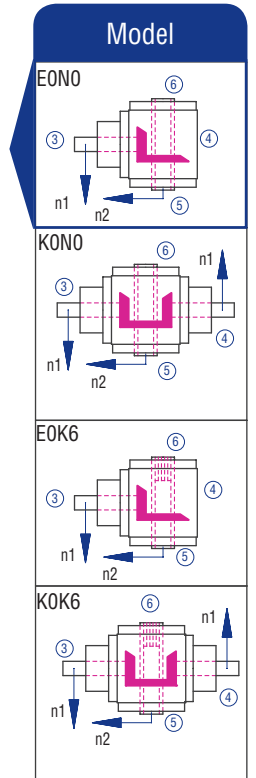
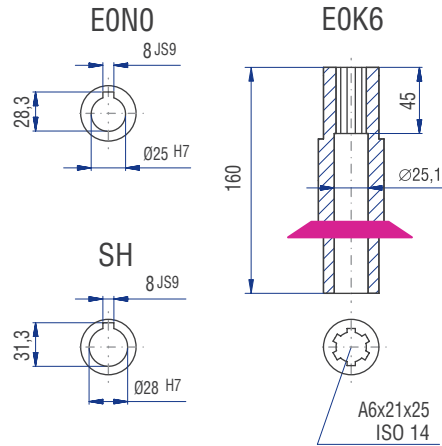
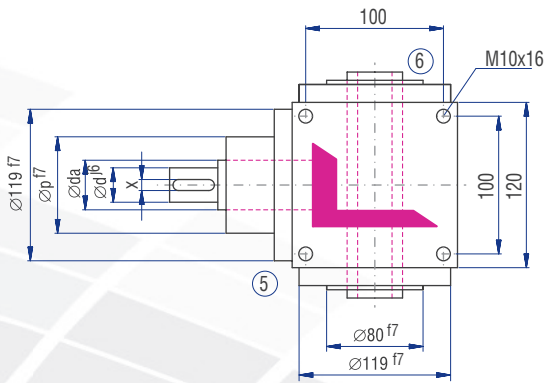

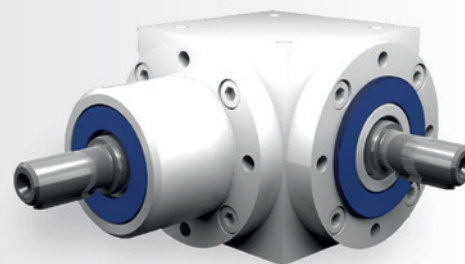

### Characteristics

Characteristic	Standard	Option
<b>Toothing</b>	Spiral toothed bevel gear set	See chapter 6.2.1
<b>Gear ratio</b>	1:1 to 6:1	
<b>Housing / Flanges</b>	Grey cast iron; steel	
<b>Threaded mounting hole</b>	On all housing surfaces without flange and on all flanges.	See chapter 6.2.3
<b>Shaft</b>	Material 1 C45, shaft ends greased Fit with ISO 6 tolerance with parallel keyway: according to DIN 6885 Sheet 1	See chapter 4.6.2
<b>Hollow shaft</b>	Material 1 C45, shafts greased Fit with ISO 7 tolerance with parallel keyway: according to DIN 6885 Sheet 1	See chapter 4.6.3
<b>Radial shaft seal ring</b>	NBR, form A	See chapter 4.8
<b>Ambient temperature</b>	-10°C to +90°C. The values of the performance tables are valid for +20°C	See chapter 4.9.3
<b>Circumferential backlash</b>	< 30 arcmin	See chapter 6.2.10
<b>Protection class</b>	IP 54	See chapter 4.5
<b>Corrosion protection</b>	Prime coat; layer thickness > 40 µm	See chapter 4.4.1
<b>Bearing life L10h</b>	more than 15,000h	See chapter 4.9.1
<b>Oil change intervals</b>	Not required if the oil temperature is kept < 90°C The lifetime of the bearings can be increased by the factor 1.5 if the oil is changed after the first 500 service hours and then every 5000 service hours.	See chapter 6.2.8
<b>Lubricant</b>	Synthetic lubricants	See chapter 6.2.8

## Performance data

n <sub>1</sub> [rpm]	1:1			1.5:1			2:1			3:1			4:1			5:1			6:1		
	n <sub>2</sub> [rpm]	P <sub>1N</sub> [kW]	T <sub>2N</sub> [Nm]	n <sub>2</sub> [rpm]	P <sub>1N</sub> [kW]	T <sub>2N</sub> [Nm]	n <sub>2</sub> [rpm]	P <sub>1N</sub> [kW]	T <sub>2N</sub> [Nm]	n <sub>2</sub> [rpm]	P <sub>1N</sub> [kW]	T <sub>2N</sub> [Nm]	n <sub>2</sub> [rpm]	P <sub>1N</sub> [kW]	T <sub>2N</sub> [Nm]	n <sub>2</sub> [rpm]	P <sub>1N</sub> [kW]	T <sub>2N</sub> [Nm]	n <sub>2</sub> [rpm]	P <sub>1N</sub> [kW]	T <sub>2N</sub> [Nm]
3000	3000	39.68	120	2000	24.91	113	1500	16.53	100	1000	12.12	110	750	8.51	103	600	6.61	100	500	5.18	94
2400	2400	37.04	140	1600	22.22	126	1200	14.68	111	800	11.46	130	600	7.34	111	480	5.56	105	400	4.58	104
1500	1500	26.78	162	1000	17.08	155	750	11.41	138	500	8.05	146	375	4.96	120	300	3.80	115	250	2.95	107
1000	1000	20.28	184	667	12.87	175	500	8.38	152	333	5.87	160	250	3.75	136	200	2.73	124	167	2.06	112
750	750	16.20	196	500	10.47	190	375	6.86	166	250	4.60	167	188	3.06	148	150	2.15	130	125	1.61	117
500	500	11.46	208	333	7.34	200	250	4.96	180	167	3.20	174	125	2.12	154	100	1.50	136	83	1.09	119
250	250	5.92	215	167	3.76	204	125	2.62	190	83	1.62	177	63	1.12	162	50	0.79	143	42	0.56	121
50	50	1.21	220	33	0.76	210	25	0.55	200	17	0.34	180	13	0.23	170	10	0.17	150	8	0.11	120

P <sub>1Nt</sub> [kW]	10.0	10.0	10.0	10.0	10.0	10.0
T <sub>2max</sub> [Nm]	430	358	320	280	280	200

### Permissible radial force F<sub>r1</sub> and axial force F<sub>a1</sub> on shaft N<sub>1</sub>

n <sub>1</sub> [rpm]	3000		1000		500		250		100		50	
T <sub>2</sub> [Nm]	F <sub>r</sub> [N]	F <sub>a</sub> [N]	F <sub>r</sub> [N]	F <sub>a</sub> [N]	F <sub>r</sub> [N]	F <sub>a</sub> [N]	F <sub>r</sub> [N]	F <sub>a</sub> [N]	F <sub>r</sub> [N]	F <sub>a</sub> [N]	F <sub>r</sub> [N]	F <sub>a</sub> [N]
< 140	700	350	870	435	1150	575	1370	685	1700	850	2000	1000
> 140	590	295	730	365	960	480	1140	570	1420	710	1670	835

### Permissible radial force F<sub>r2</sub> and axial force F<sub>a2</sub> on shaft N<sub>2</sub>

n <sub>2</sub> [rpm]	3000		1000		500		250		100		50	
T <sub>2</sub> [Nm]	F <sub>r</sub> [N]	F <sub>a</sub> [N]	F <sub>r</sub> [N]	F <sub>a</sub> [N]	F <sub>r</sub> [N]	F <sub>a</sub> [N]	F <sub>r</sub> [N]	F <sub>a</sub> [N]	F <sub>r</sub> [N]	F <sub>a</sub> [N]	F <sub>r</sub> [N]	F <sub>a</sub> [N]
< 140	1300	650	1700	850	2000	1000	2500	1250	3000	1500	3800	1900
> 140	1082	541	1420	710	1670	835	2080	1040	2500	1250	3170	1585

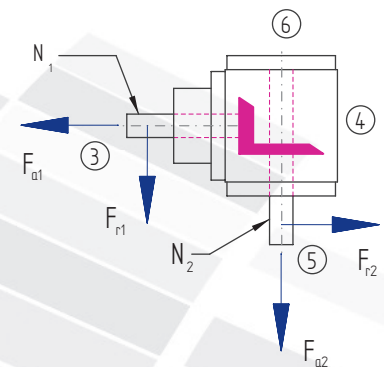

### Inertia moments/mass

Inertia moment J<sub>1</sub> related to the fast-rotating shaft (N<sub>1</sub>)

Model	Inertia moment [kgcm <sup>2</sup> ]								Mass [kg]
	1:1	1.5:1	2:1	3:1	4:1	5:1	6:1		
A0	26.2670	11.8569	8.6762	6.43560	1.84320	1.53200	1.37080	19.0	
B0	36.0994	18.7513	12.2785	7.95470	2.69780	2.21130	1.84260	18.5	
C0	36.0994	18.7513	12.2785	7.95470	2.69780	2.21130	1.84260	18.5	
D0	37.0815	19.1878	12.5241	8.06390	2.75920	2.25060	1.86980	19.0	
E0N	32.6630	17.2240	11.4194	7.57290	2.48300	2.07390	1.74710	18.0	
E0S	39.0643	20.0691	13.0198	8.28420	2.88310	2.32990	1.92490	18.7	
F0	39.4005	17.6940	11.9596	7.89490	2.66410	2.05740	1.73560	23.0	
G0	49.2329	24.7711	17.6713	12.9310	3.72020	3.21800	2.84860	22.7	
H0	49.2329	24.7711	17.6713	12.9310	3.72020	3.21800	2.84860	22.7	
J0	50.2150	25.2076	17.9169	13.0402	3.78160	3.25730	2.87580	23.2	
K0N	45.7965	23.2438	16.8122	12.5492	3.50540	3.08060	2.75310	22.2	
K0S	52.1978	26.0889	18.4126	13.2605	3.90550	3.33660	2.93090	22.9	

# 6.3.9 Type V 140 – Standard bevel gearboxes

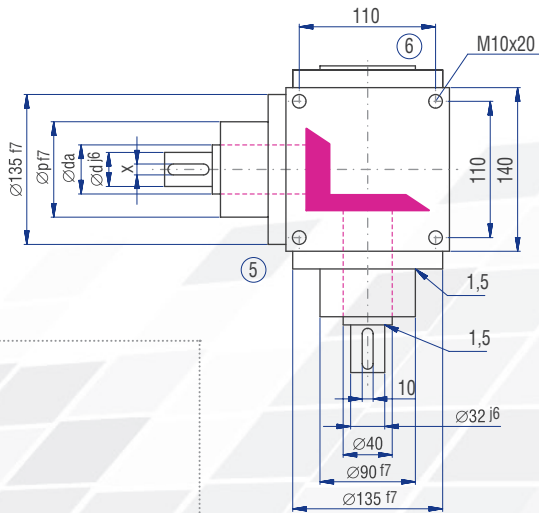
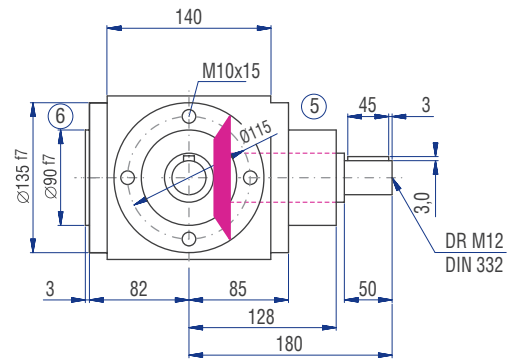
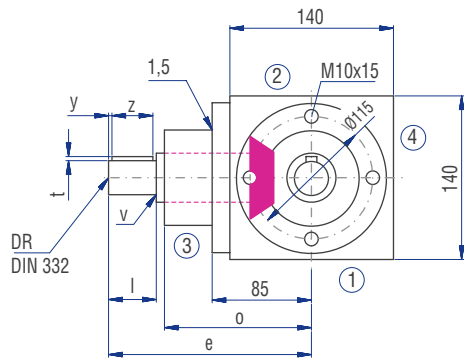
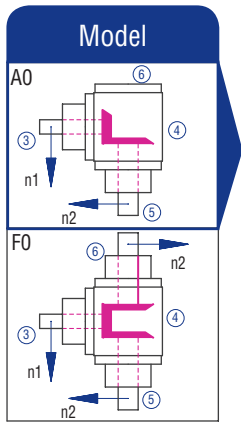

	Gear ratio						
	1:1	1.5:1	2:1	3:1	4:1	5:1	6:1
d [mm]	32	32	32	28	24	24	24
da [mm]	40	40	40	40	40	40	40
l [mm]	50	50	50	50	50	50	50
v [mm]	1.5	1.5	1.5	1	1	1	1
x [mm]	10	10	10	8	8	8	8
y [mm]	3	3	3	3	3	3	3
z [mm]	45	45	45	45	45	45	45
t [mm]	3	3	3	3	3	3	3
e [mm]	180	180	180	180	195	195	195
o [mm]	128	128	128	128	143	143	143
p [mm]	90	90	90	90	85	85	85
DR M	12	12	12	10	8	8	8

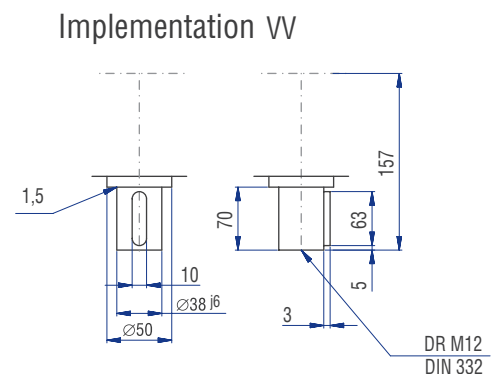
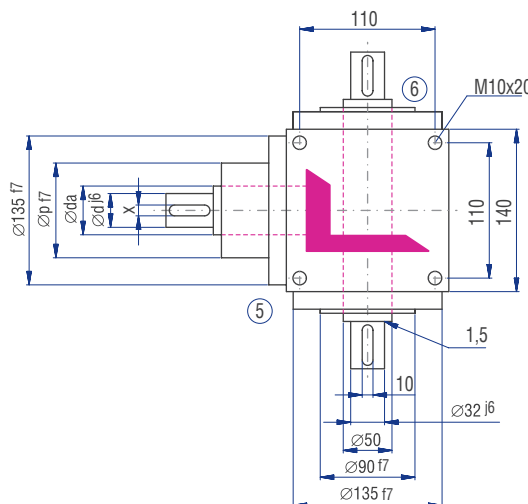
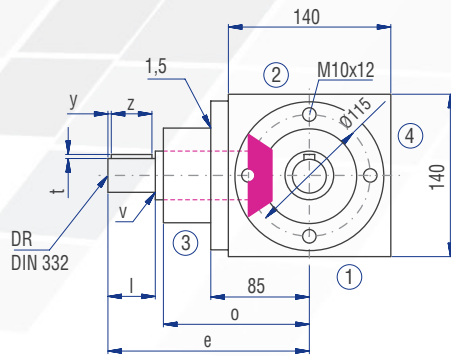
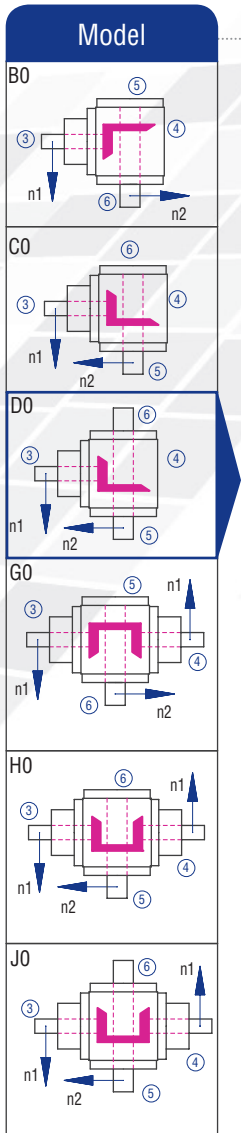

## Implementation VV

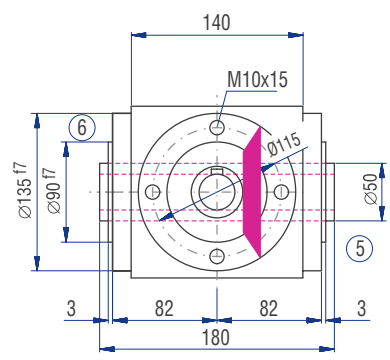
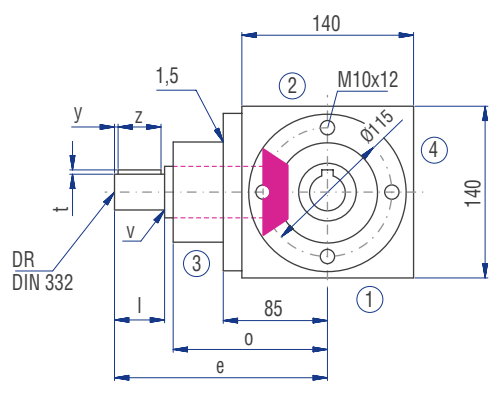

### Implementation

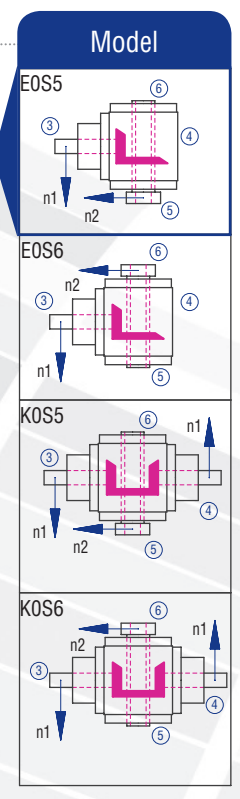
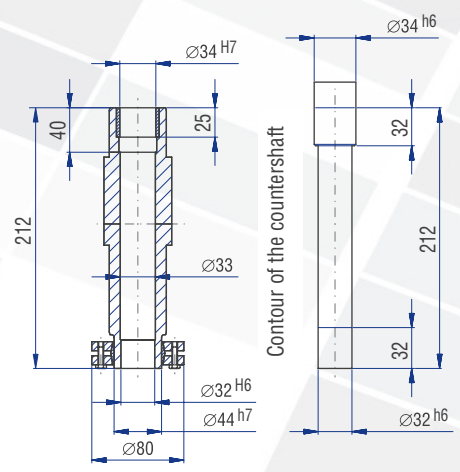
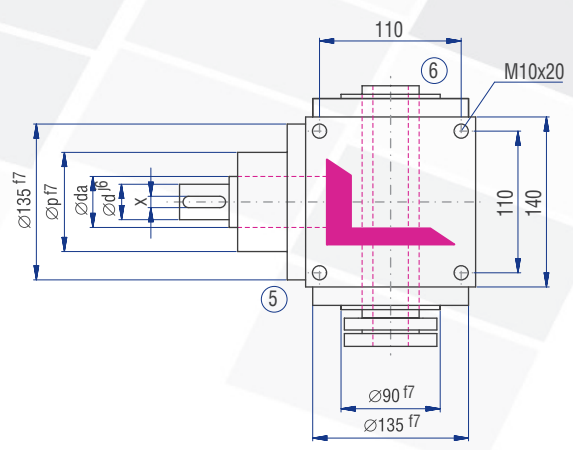
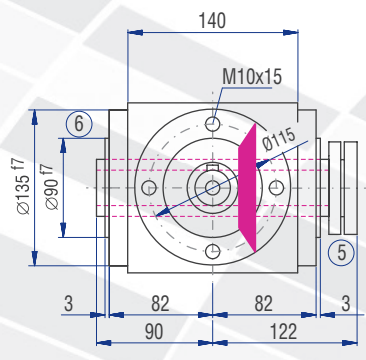
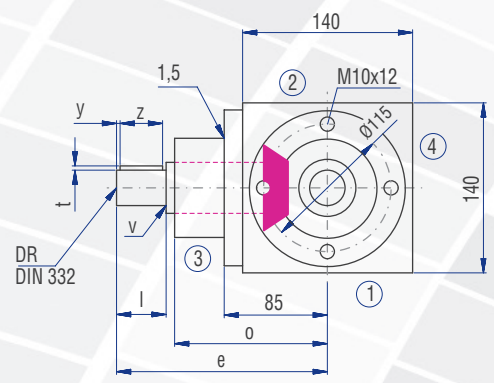
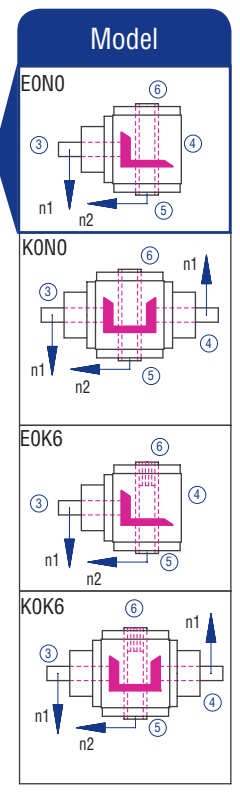
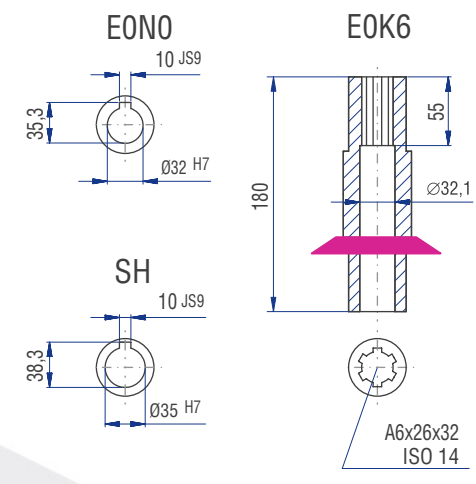
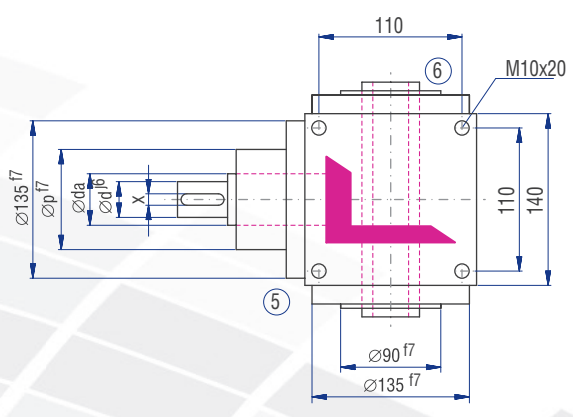

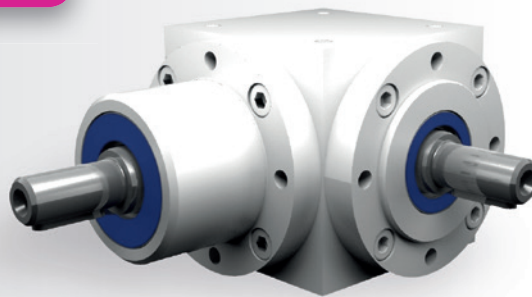

### Characteristics

Characteristic	Standard	Option
<b>Toothing</b>	Spiral toothed bevel gear set	See chapter 6.2.1
<b>Gear ratio</b>	1:1 to 6:1	
<b>Housing / Flanges</b>	Grey cast iron; steel	
<b>Threaded mounting hole</b>	On all housing surfaces without flange and on all flanges.	See chapter 6.2.3
<b>Shaft</b>	Material 1 C45, shaft ends greased Fit with ISO 6 tolerance with parallel keyway: according to DIN 6885 Sheet 1	See chapter 4.6.2
<b>Hollow shaft</b>	Material 1 C45, shafts greased Fit with ISO 7 tolerance with parallel keyway: according to DIN 6885 Sheet 1	See chapter 4.6.3
<b>Radial shaft seal ring</b>	NBR, form A	See chapter 4.8
<b>Ambient temperature</b>	-10°C to +90°C. The values of the performance tables are valid for +20°C	See chapter 4.9.3
<b>Circumferential backlash</b>	< 30 arcmin	See chapter 6.2.10
<b>Protection class</b>	IP 54	See chapter 4.5
<b>Corrosion protection</b>	Prime coat; layer thickness > 40 µm	See chapter 4.4.1
<b>Bearing life L10h</b>	more than 15,000h	See chapter 4.9.1
<b>Oil change intervals</b>	Not required if the oil temperature is kept < 90°C The lifetime of the bearings can be increased by the factor 1.5 if the oil is changed after the first 500 service hours and then every 5000 service hours.	See chapter 6.2.8
<b>Lubricant</b>	Synthetic lubricants	See chapter 6.2.8

## Performance data

n <sub>1</sub> [rpm]	1:1		1.5:1			2:1			3:1			4:1			5:1			6:1			
	n <sub>2</sub> [rpm]	P <sub>1N</sub> [kW]	T <sub>2N</sub> [Nm]	n <sub>2</sub> [rpm]	P <sub>1N</sub> [kW]	T <sub>2N</sub> [Nm]	n <sub>2</sub> [rpm]	P <sub>1N</sub> [kW]	T <sub>2N</sub> [Nm]	n <sub>2</sub> [rpm]	P <sub>1N</sub> [kW]	T <sub>2N</sub> [Nm]	n <sub>2</sub> [rpm]	P <sub>1N</sub> [kW]	T <sub>2N</sub> [Nm]	n <sub>2</sub> [rpm]	P <sub>1N</sub> [kW]	T <sub>2N</sub> [Nm]	n <sub>2</sub> [rpm]	P <sub>1N</sub> [kW]	T <sub>2N</sub> [Nm]
3000				2000	40.78	185	1500	28.11	170	1000	20.94	190	750	14.88	180	600	11.90	180	500	7.09	129
2400	2400	57.67	218	1600	36.15	205	1200	25.53	193	800	17.81	202	600	13.23	200	480	10.48	198	400	5.98	136
1500	1500	42.99	260	1000	27.78	252	750	20.25	245	500	12.68	230	375	9.09	220	300	7.11	215	250	3.95	143
1000	1000	31.96	290	667	20.59	280	500	14.88	270	333	8.99	245	250	6.61	240	200	4.96	225	167	3.01	164
750	750	25.63	310	500	16.26	295	375	11.57	280	250	6.89	250	188	5.17	250	150	3.97	240	125	2.43	176
500	500	18.19	330	333	11.56	315	250	8.27	300	167	4.79	260	125	3.58	260	100	2.76	250	83	1.72	187
250	250	9.64	350	167	6.07	330	125	4.41	320	83	2.56	280	63	1.86	270	50	1.49	270	42	0.92	199
50	50	2.09	380	33	1.29	355	25	0.98	355	17	0.57	305	13	0.39	280	10	0.32	290	8	0.18	197
P <sub>1Nt</sub> [kW]		15.0		15.0			15.0			15.0			15.0			15.0			15.0		
T <sub>2max</sub> [Nm]		660		650			650			457			422			420			350		

### Permissible radial force F<sub>r1</sub> and axial force F<sub>a1</sub> on shaft N<sub>1</sub>

n <sub>1</sub> [rpm]	3000		1000		500		250		100		50	
T <sub>2</sub> [Nm]	F <sub>r</sub> [N]	F <sub>a</sub> [N]	F <sub>r</sub> [N]	F <sub>a</sub> [N]	F <sub>r</sub> [N]	F <sub>a</sub> [N]	F <sub>r</sub> [N]	F <sub>a</sub> [N]	F <sub>r</sub> [N]	F <sub>a</sub> [N]	F <sub>r</sub> [N]	F <sub>a</sub> [N]
< 220	1200	600	1600	800	1900	950	2200	1100	2850	1425	3300	1650
> 220	1000	500	1340	670	1590	795	1840	920	2380	1190	2750	1375

### Permissible radial force F<sub>r2</sub> and axial force F<sub>a2</sub> on shaft N<sub>2</sub>

n <sub>2</sub> [rpm]	3000		1000		500		250		100		50	
T <sub>2</sub> [Nm]	F <sub>r</sub> [N]	F <sub>a</sub> [N]	F <sub>r</sub> [N]	F <sub>a</sub> [N]	F <sub>r</sub> [N]	F <sub>a</sub> [N]	F <sub>r</sub> [N]	F <sub>a</sub> [N]	F <sub>r</sub> [N]	F <sub>a</sub> [N]	F <sub>r</sub> [N]	F <sub>a</sub> [N]
< 220	2000	1000	2800	1400	3300	1650	4000	2000	5000	2500	6500	3250
> 220	1670	835	2340	1170	2750	1375	3340	1670	4170	2085	5420	2710

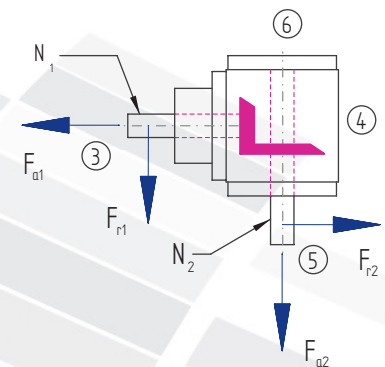

### Inertia moments/mass

Inertia moment J<sub>1</sub> related to the fast-rotating shaft (N<sub>1</sub>)

Model	Inertia moment [kgcm <sup>2</sup> ]							Mass [kg]
	1:1	1.5:1	2:1	3:1	4:1	5:1	6:1	
A0	29.6710	19.6374	12.3589	8.9516	6.4348	2.2733	2.0901	28.5
B0	31.5527	32.0243	20.1006	12.0803	8.4198	3.6887	2.9407	28.0
C0	31.5527	32.0243	20.1006	12.0803	8.4198	3.6887	2.9407	28.0
D0	32.5820	32.4818	20.3579	12.1947	8.4841	3.7299	2.9693	28.5
E0N	34.3851	33.1416	20.6658	12.3315	8.5611	3.7791	3.0048	27.0
E0S	40.6750	35.9371	22.2382	13.0304	8.9542	4.0307	3.1795	27.5
F0	44.5065	26.2309	16.0678	10.6000	7.3620	2.8667	2.5022	35.0
G0	46.3882	45.0681	28.7506	19.3835	13.9274	5.3686	4.6187	34.5
H0	46.3882	45.0681	28.7506	19.3835	13.9274	5.3686	4.6187	34.5
J0	47.4175	45.5256	29.0079	19.4979	13.9917	5.4098	4.6473	35.0
K0N	49.2206	46.1854	29.3158	19.6347	14.0687	5.4590	4.6828	34.0
K0S	55.5105	48.9809	30.8882	20.3336	14.4618	5.7106	4.8575	34.5

# 6.3.10 Type V 160 – Standard bevel gearboxes

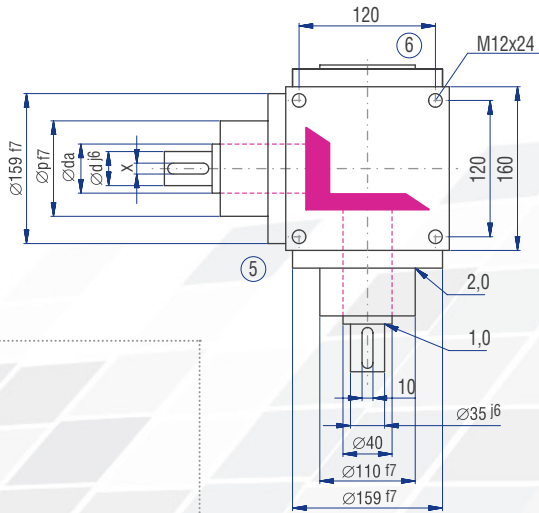
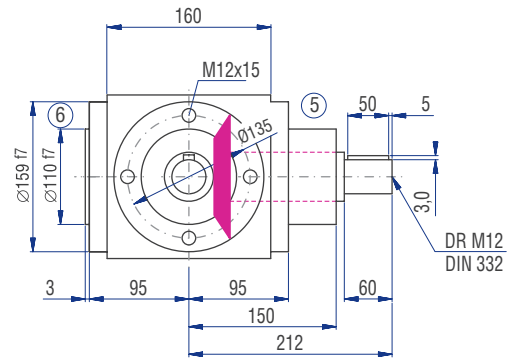
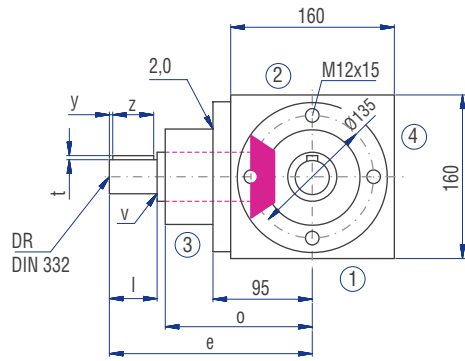
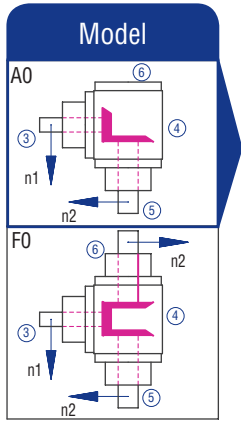

	Gear ratio						
	1:1	1.5:1	2:1	3:1	4:1	5:1	6:1
d [mm]	35	35	35	28	24	24	24
da [mm]	40	40	40	40	40	25	25
l [mm]	60	60	60	60	60	60	60
v [mm]	1.5	1.5	1.5	1	1	0.5	0.5
x [mm]	10	10	10	8	8	8	8
y [mm]	5	5	5	5	5	5	5
z [mm]	50	50	50	50	50	50	50
t [mm]	3	3	3	3	3	3	3
e [mm]	212	212	212	212	232	232	232
o [mm]	150	150	150	150	170	170	170
p [mm]	110	110	110	100	100	100	100
DR M	12	12	12	10	8	8	8

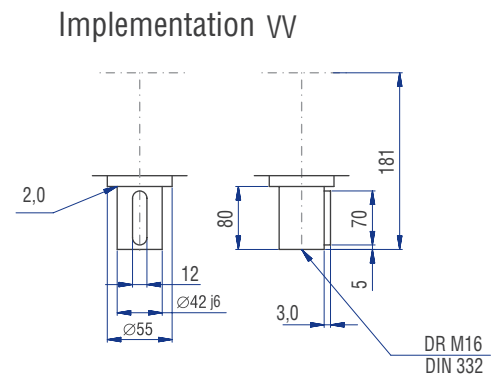
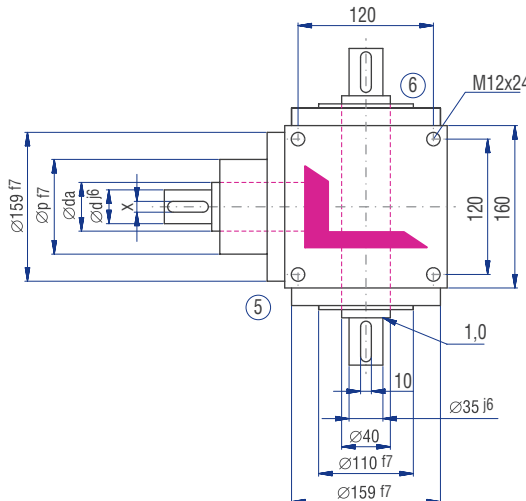
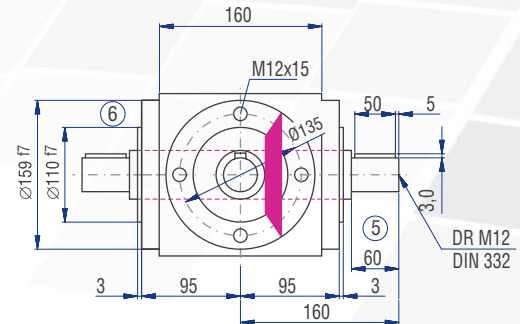
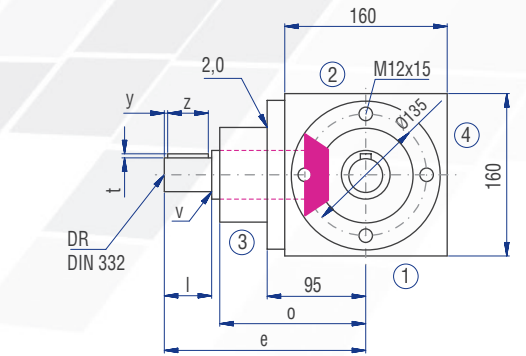
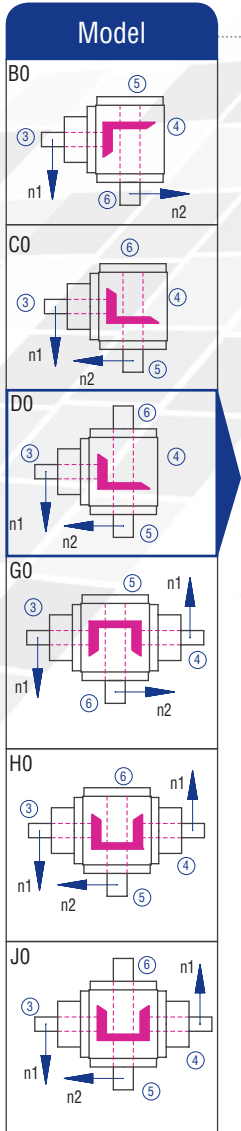

## Implementation VV

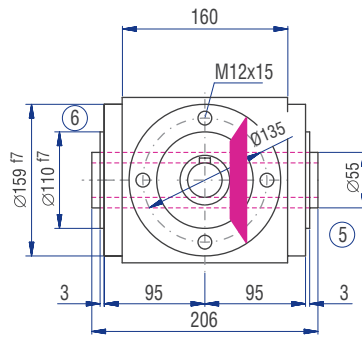
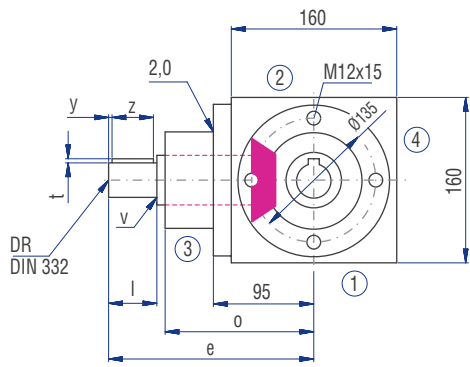

Implementation

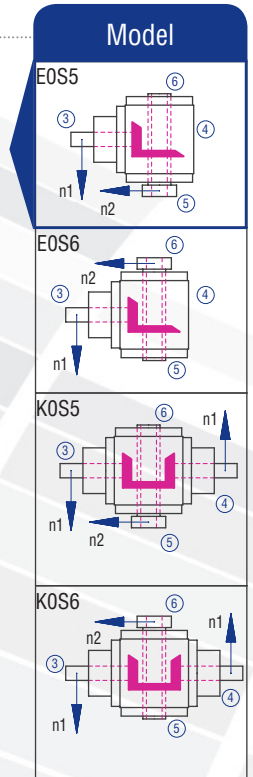
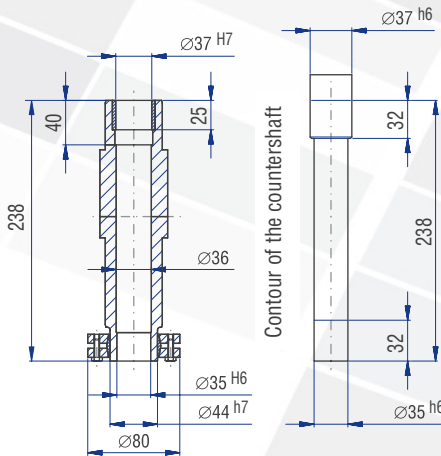
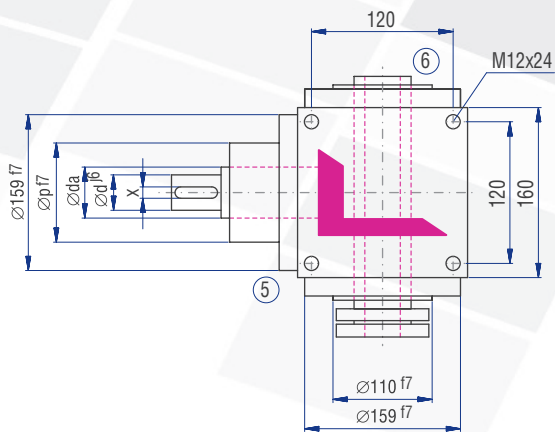
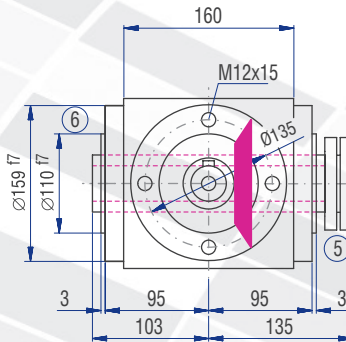
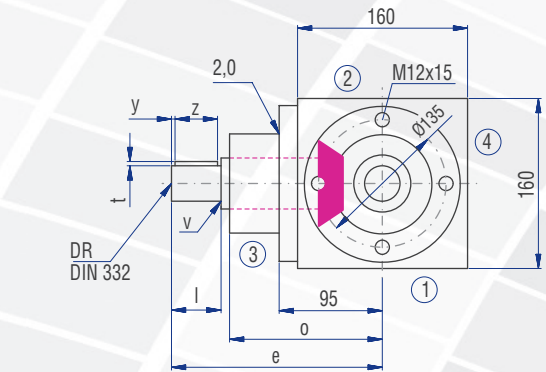
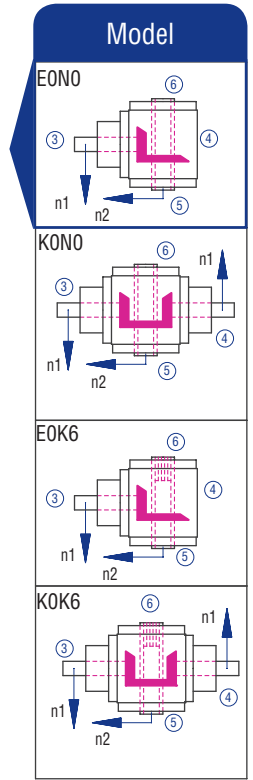
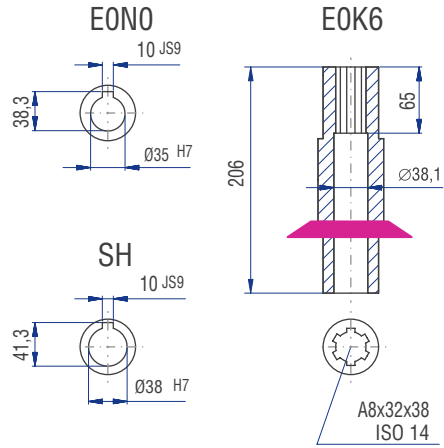
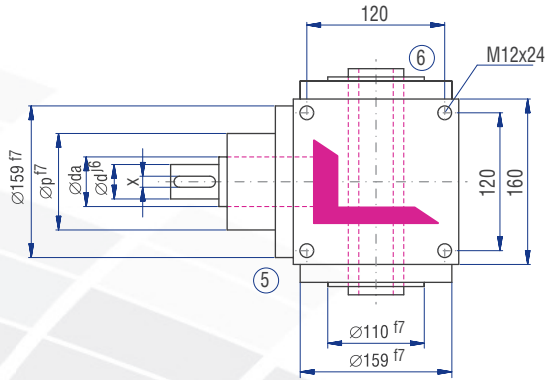

## 6.3.11 Type V 200 – Standard bevel gearboxes

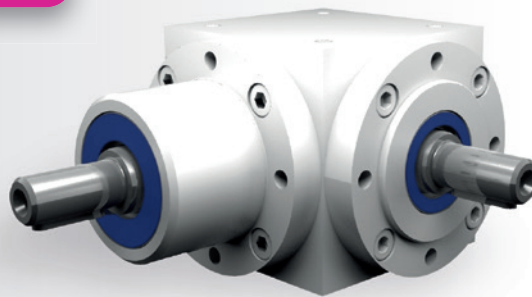

### Characteristics

Characteristic	Standard	Option
<b>Toothing</b>	Spiral toothed bevel gear set	See chapter 6.2.1
<b>Gear ratio</b>	1:1 to 6:1	
<b>Housing / Flanges</b>	Grey cast iron; steel	
<b>Threaded mounting hole</b>	On all housing surfaces without flange and on all flanges.	See chapter 6.2.3
<b>Shaft</b>	Material 1 C45, shaft ends greased Fit with ISO 6 tolerance with parallel keyway: according to DIN 6885 Sheet 1	See chapter 4.6.2
<b>Hollow shaft</b>	Material 1 C45, shafts greased Fit with ISO 7 tolerance with parallel keyway: according to DIN 6885 Sheet 1	See chapter 4.6.3
<b>Radial shaft seal ring</b>	NBR, form A	See chapter 4.8
<b>Ambient temperature</b>	-10°C to +90°C. The values of the performance tables are valid for +20°C	See chapter 4.9.3
<b>Circumferential backlash</b>	< 30 arcmin	See chapter 6.2.10
<b>Protection class</b>	IP 54	See chapter 4.5
<b>Corrosion protection</b>	Prime coat; layer thickness > 40 µm	See chapter 4.4.1
<b>Bearing life L10h</b>	more than 15,000h	See chapter 4.9.1
<b>Oil change intervals</b>	Not required if the oil temperature is kept < 90°C The lifetime of the bearings can be increased by the factor 1.5 if the oil is changed after the first 500 service hours and then every 5000 service hours.	See chapter 6.2.8
<b>Lubricant</b>	Synthetic lubricants	See chapter 6.2.8

## Performance data

n <sub>1</sub> [rpm]	1:1		1.5:1			2:1			3:1			4:1			5:1			6:1						
	n <sub>2</sub> [rpm]	P <sub>1N</sub> [kW]	T <sub>2N</sub> [Nm]	n <sub>2</sub> [rpm]	P <sub>1N</sub> [kW]	T <sub>2N</sub> [Nm]	n <sub>2</sub> [rpm]	P <sub>1N</sub> [kW]	T <sub>2N</sub> [Nm]	n <sub>2</sub> [rpm]	P <sub>1N</sub> [kW]	T <sub>2N</sub> [Nm]	n <sub>2</sub> [rpm]	P <sub>1N</sub> [kW]	T <sub>2N</sub> [Nm]	n <sub>2</sub> [rpm]	P <sub>1N</sub> [kW]	T <sub>2N</sub> [Nm]	n <sub>2</sub> [rpm]	P <sub>1N</sub> [kW]	T <sub>2N</sub> [Nm]			
3000				2000	72.75	330	1500	51.25	310	1000	46.29	420	750	28.93	350	600	19.84	300	500	11.45	208			
2400				1600	63.49	360	1200	45.24	342	800	39.24	445	600	26.45	400	480	17.99	340	400	9.60	218			
1500	1500	74.40	450	1000	48.17	437	750	35.13	425	500	28.38	515	375	18.81	455	300	12.57	380	250	6.54	237			
1000	1000	56.21	510	667	37.13	505	500	27.56	500	333	20.37	555	250	13.36	485	200	9.26	420	167	4.74	258			
750	750	45.88	555	500	30.31	550	375	22.32	540	250	15.98	580	188	10.54	510	150	7.27	440	125	3.98	289			
500	500	34.17	620	333	22.57	615	250	16.81	610	167	11.04	600	125	7.23	525	100	5.18	470	83	2.79	304			
250	250	19.56	710	167	12.70	690	125	9.37	680	83	5.76	630	63	3.79	550	50	2.78	505	42	1.44	311			
50	50	4.13	750	33	2.73	750	25	2.07	750	17	1.29	690	13	0.80	580	10	0.58	525	8	0.28	306			
P <sub>1Nt</sub> [kW]		26.0		26.0			26.0			26.0			26.0			26.0			26.0					
T <sub>2max</sub> [Nm]		1090		980			980			910			860			860			625					

### Permissible radial force F<sub>r1</sub> and axial force F<sub>a1</sub> on shaft N<sub>1</sub>

n <sub>1</sub> [rpm]	3000		1000		500		250		100		50	
T <sub>2</sub> [Nm]	F <sub>r</sub> [N]	F <sub>a</sub> [N]	F <sub>r</sub> [N]	F <sub>a</sub> [N]	F <sub>r</sub> [N]	F <sub>a</sub> [N]	F <sub>r</sub> [N]	F <sub>a</sub> [N]	F <sub>r</sub> [N]	F <sub>a</sub> [N]	F <sub>r</sub> [N]	F <sub>a</sub> [N]
< 500	2200	1100	1700	850	3200	1600	3900	1950	5000	2500	6200	3100
> 500	1840	920	1420	710	2670	1335	3250	1625	4170	2085	5170	2585

### Permissible radial force F<sub>r2</sub> and axial force F<sub>a2</sub> on shaft N<sub>2</sub>

n <sub>2</sub> [rpm]	3000		1000		500		250		100		50	
T <sub>2</sub> [Nm]	F <sub>r</sub> [N]	F <sub>a</sub> [N]	F <sub>r</sub> [N]	F <sub>a</sub> [N]	F <sub>r</sub> [N]	F <sub>a</sub> [N]	F <sub>r</sub> [N]	F <sub>a</sub> [N]	F <sub>r</sub> [N]	F <sub>a</sub> [N]	F <sub>r</sub> [N]	F <sub>a</sub> [N]
< 500	3200	1600	4300	2150	5000	2500	6500	3250	8000	4000	10000	5000
> 500	2670	1335	3580	1790	4170	2085	5420	2710	6670	3335	8330	4165

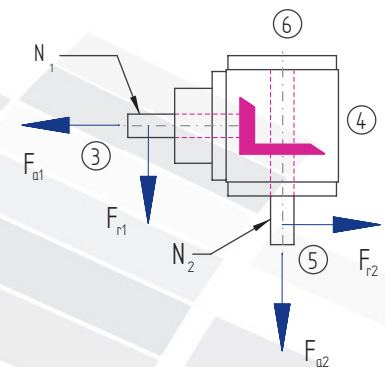

### Inertia moments/mass

Inertia moment J<sub>1</sub> related to the fast-rotating shaft (N<sub>1</sub>)

Model	Inertia moment [kgcm <sup>2</sup> ]							Mass [kg]
	1:1	1.5:1	2:1	3:1	4:1	5:1	6:1	
A0	121.2522	57.6950	36.3095	18.8322	14.2651	6.1470	5.3881	52.0
B0	174.7000	103.5829	71.6215	34.1931	22.7181	12.8770	10.0616	48.0
C0	174.7000	103.5829	71.6215	34.1931	22.7181	12.8770	10.0616	48.0
D0	177.8173	104.9684	72.4008	34.5395	22.9130	13.0016	10.1482	50.0
E0N	201.3904	109.0276	76.4341	35.2209	23.3588	13.8070	10.7075	48.0
E0S	222.4124	118.3707	81.6896	37.5567	24.6726	14.6479	11.2914	49.3
F0	181.8783	84.6400	51.4661	25.5685	18.0543	8.5721	7.0721	60.0
G0	235.3261	134.3330	92.7745	46.2891	33.1941	16.5990	13.7656	58.0
H0	235.3261	134.3330	92.7745	46.2891	33.1941	16.5990	13.7656	58.0
J0	238.4434	135.7185	93.5538	46.6355	33.3890	16.7236	13.8522	60.0
K0N	262.0165	139.7777	97.5871	47.3169	33.8348	17.5290	14.4115	58.0
K0S	283.0385	149.1208	102.8426	49.6527	35.1486	18.3699	14.9954	59.3

# 6.3.11 Type V 200 – Standard bevel gearboxes

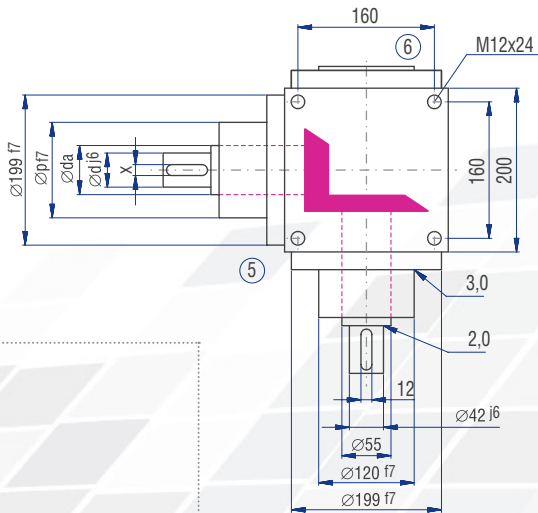
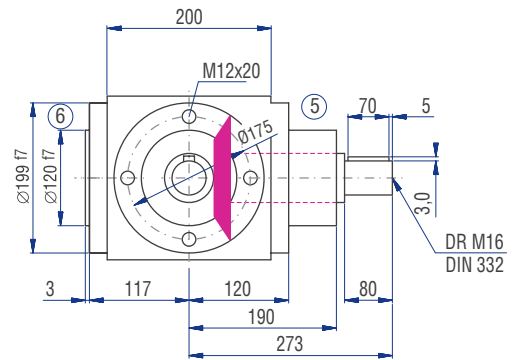
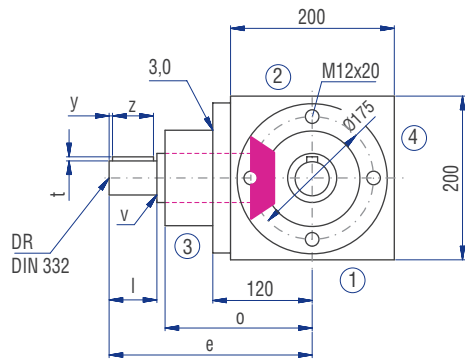
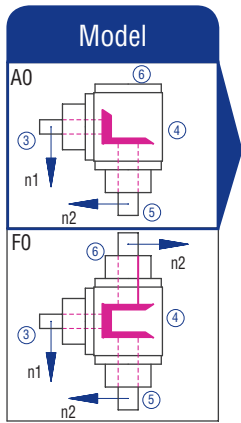

	Gear ratio						
	1:1	1.5:1	2:1	3:1	4:1	5:1	6:1
d [mm]	42	42	42	35	35	28	28
da [mm]	55	55	55	40	40	30	30
l [mm]	80	80	80	68	68	68	68
v [mm]	2	2	2	1	1	0	0
x [mm]	12	12	12	10	10	8	8
y [mm]	5	5	5	3	3	3	3
z [mm]	70	70	70	63	63	63	63
t [mm]	3	3	3	3	3	3	3
e [mm]	273	273	273	261	261	261	261
o [mm]	190	190	190	190	190	190	190
p [mm]	120	120	120	120	120	110	110
DR M	16	16	16	12	12	10	10

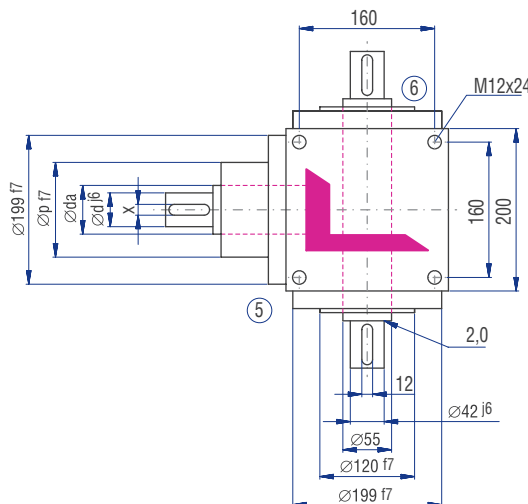
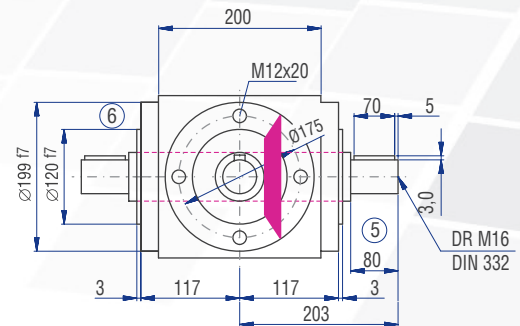
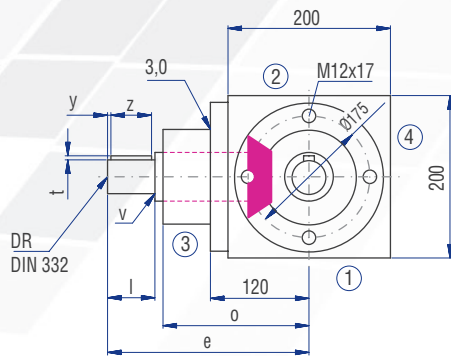
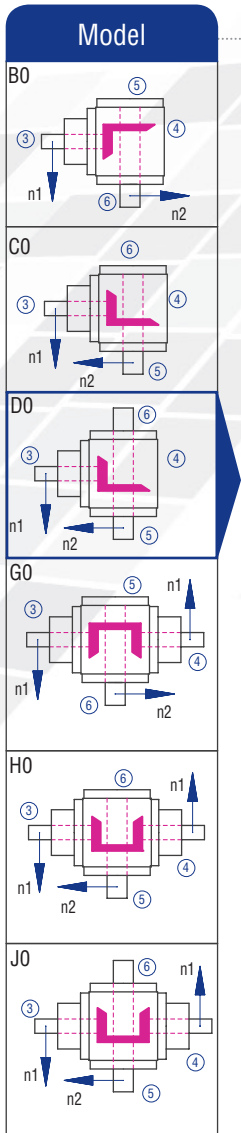

## Implementation VV

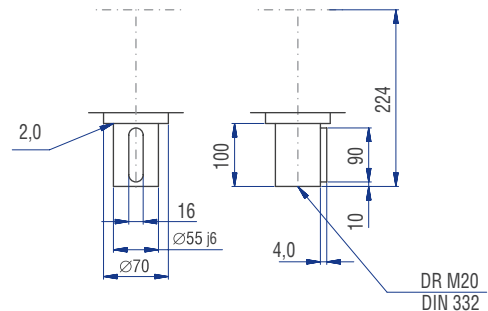

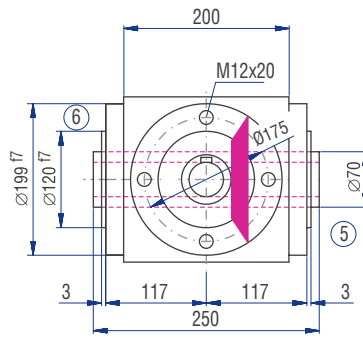
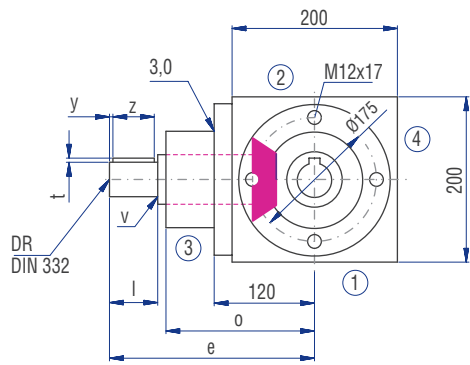

Implementation

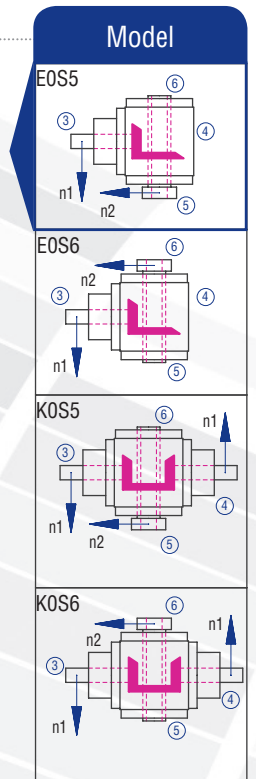
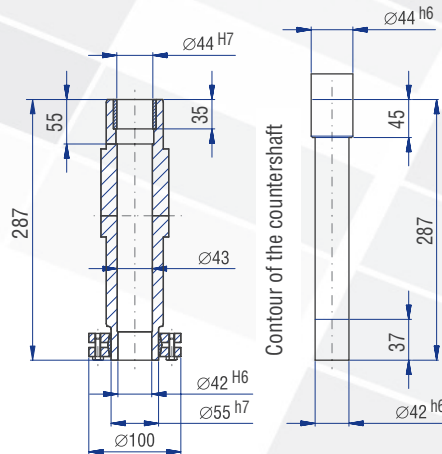
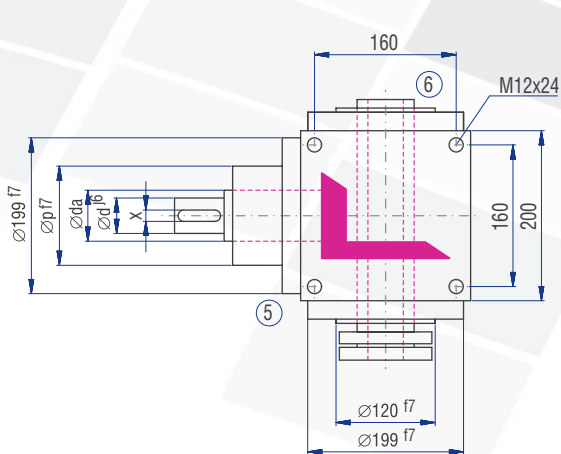
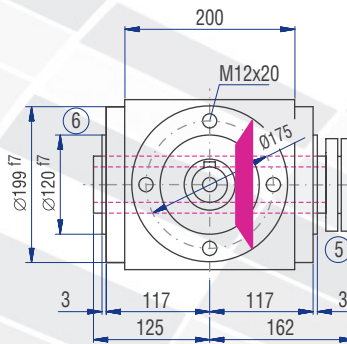
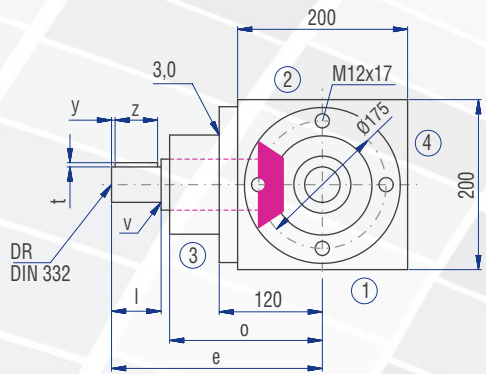
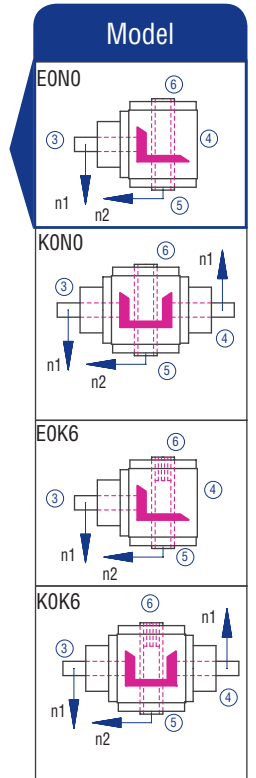
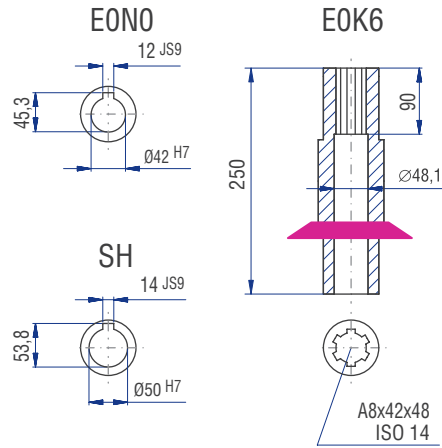
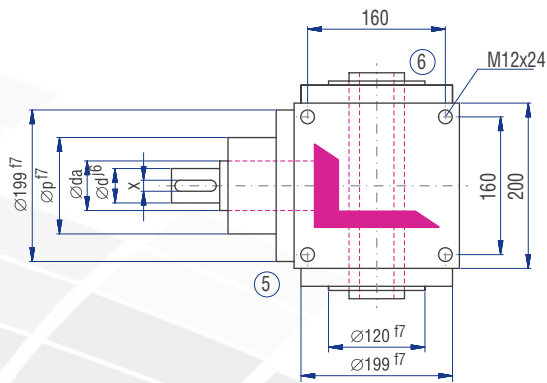

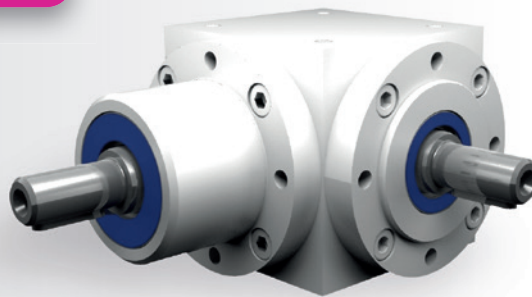

### Characteristics

Characteristic	Standard	Option
<b>Toothing</b>	Spiral toothed bevel gear set	See chapter 6.2.1
<b>Gear ratio</b>	1:1 to 6:1	
<b>Housing / Flanges</b>	Grey cast iron; steel	
<b>Threaded mounting hole</b>	On all housing surfaces without flange and on all flanges.	See chapter 6.2.3
<b>Shaft</b>	Material 1 C45, shaft ends greased Fit with ISO 6 tolerance with parallel keyway: according to DIN 6885 Sheet 1	See chapter 4.6.2
<b>Hollow shaft</b>	Material 1 C45, shafts greased Fit with ISO 7 tolerance with parallel keyway: according to DIN 6885 Sheet 1	See chapter 4.6.3
<b>Radial shaft seal ring</b>	NBR, form A	See chapter 4.8
<b>Ambient temperature</b>	-10°C to +90°C. The values of the performance tables are valid for +20°C	See chapter 4.9.3
<b>Circumferential backlash</b>	< 30 arcmin	See chapter 6.2.10
<b>Protection class</b>	IP 54	See chapter 4.5
<b>Corrosion protection</b>	Prime coat; layer thickness > 40 µm	See chapter 4.4.1
<b>Bearing life L10h</b>	more than 15,000h	See chapter 4.9.1
<b>Oil change intervals</b>	Not required if the oil temperature is kept < 90°C The lifetime of the bearings can be increased by the factor 1.5 if the oil is changed after the first 500 service hours and then every 5000 service hours.	See chapter 6.2.8
<b>Lubricant</b>	Synthetic lubricants	See chapter 6.2.8

## Performance data

n <sub>1</sub> [rpm]	1:1		1.5:1			2:1			3:1			4:1			5:1			6:1						
	n <sub>2</sub> [rpm]	P <sub>1N</sub> [kW]	T <sub>2N</sub> [Nm]	n <sub>2</sub> [rpm]	P <sub>1N</sub> [kW]	T <sub>2N</sub> [Nm]	n <sub>2</sub> [rpm]	P <sub>1N</sub> [kW]	T <sub>2N</sub> [Nm]	n <sub>2</sub> [rpm]	P <sub>1N</sub> [kW]	T <sub>2N</sub> [Nm]	n <sub>2</sub> [rpm]	P <sub>1N</sub> [kW]	T <sub>2N</sub> [Nm]	n <sub>2</sub> [rpm]	P <sub>1N</sub> [kW]	T <sub>2N</sub> [Nm]	n <sub>2</sub> [rpm]	P <sub>1N</sub> [kW]	T <sub>2N</sub> [Nm]			
3000				2000	99.20	450	1500	87.63	530	1000	44.09	400	750	36.37	440	600	33.73	510	500	20.17	366			
2400				1600	91.35	518	1200	80.02	605	800	39.68	450	600	32.74	495	480	29.10	550	400	18.08	410			
1500	1500	87.63	530	1000	72.20	655	750	59.11	715	500	29.76	540	375	24.80	600	300	21.00	635	250	13.50	490			
1000	1000	71.65	650	667	56.21	765	500	45.19	820	333	23.33	635	250	18.60	675	200	15.76	715	167	9.92	540			
750	750	60.76	735	500	45.47	825	375	36.79	890	250	19.29	700	188	15.19	735	150	12.73	770	125	7.78	565			
500	500	45.19	820	333	33.79	920	250	26.73	970	167	14.07	765	125	10.95	795	100	9.15	830	83	5.42	590			
250	250	26.73	970	167	20.57	1,120	125	16.88	1,225	83	7.58	825	63	5.99	870	50	5.07	920	42	2.82	610			
50	50	7.00	1,270	33	4.89	1,330	25	3.66	1,330	17	1.63	870	13	1.35	980	10	1.09	990	8	0.57	625			
P <sub>1Nt</sub> [kW]		34.0		34.0			34.0			34.0			34.0			34.0			34.0					
T <sub>2max</sub> [Nm]		1500		1400			1400			1300			1300			1200			1000					

### Permissible radial force F<sub>r1</sub> and axial force F<sub>a1</sub> on shaft N<sub>1</sub>

n <sub>1</sub> [rpm]	3000		1000		500		250		100		50	
T <sub>2</sub> [Nm]	F <sub>r</sub> [N]	F <sub>a</sub> [N]	F <sub>r</sub> [N]	F <sub>a</sub> [N]	F <sub>r</sub> [N]	F <sub>a</sub> [N]	F <sub>r</sub> [N]	F <sub>a</sub> [N]	F <sub>r</sub> [N]	F <sub>a</sub> [N]	F <sub>r</sub> [N]	F <sub>a</sub> [N]
< 750	4600	2300	5150	2575	7200	3600	9450	4725	11250	5625	13100	6550
> 750	3832	1916	4290	2145	6000	3000	7876	3938	9376	4688	10918	5459

### Permissible radial force F<sub>r2</sub> and axial force F<sub>a2</sub> on shaft N<sub>2</sub>

n <sub>2</sub> [rpm]	3000		1000		500		250		100		50	
T <sub>2</sub> [Nm]	F <sub>r</sub> [N]	F <sub>a</sub> [N]	F <sub>r</sub> [N]	F <sub>a</sub> [N]	F <sub>r</sub> [N]	F <sub>a</sub> [N]	F <sub>r</sub> [N]	F <sub>a</sub> [N]	F <sub>r</sub> [N]	F <sub>a</sub> [N]	F <sub>r</sub> [N]	F <sub>a</sub> [N]
< 750	5850	2925	8650	4325	10500	5250	12250	6125	15000	7500	19000	9500
> 750	4876	2438	7208	3604	8750	4375	10208	5104	12500	6250	15830	7915

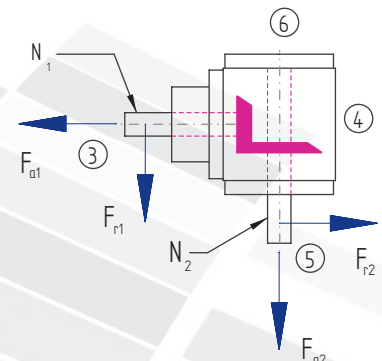

### Inertia moments/mass

Inertia moment J<sub>1</sub> related to the fast-rotating shaft (N<sub>1</sub>)

Model	Inertia moment [kgcm <sup>2</sup> ]							Mass [kg]
	1:1	1.5:1	2:1	3:1	4:1	5:1	6:1	
A0	506.0000	215.0000	132.0000	55.0000	48.0000	42.0000	37.0000	79.0
B0	502.0000	220.0000	136.0000	57.0000	49.0000	42.0000	38.0000	76.0
C0	502.0000	220.0000	136.0000	57.0000	49.0000	42.0000	38.0000	76.0
D0	512.0000	224.0000	138.0000	58.0000	49.0000	43.0000	38.0000	78.0
E0N	512.0000	229.0000	142.0000	60.0000	50.0000	43.0000	38.0000	71.0
E0S	573.0000	256.0000	157.0000	67.0000	54.0000	46.0000	40.0000	72.0
F0	759.0000	332.0000	201.0000	77.0000	63.0000	53.0000	45.0000	97.0
G0	755.0000	318.0000	200.0000	91.0000	82.0000	72.0000	68.0000	100.0
H0	755.0000	318.0000	200.0000	91.0000	82.0000	72.0000	68.0000	100.0
J0	765.0000	322.0000	202.0000	92.0000	82.0000	73.0000	68.0000	102.0
K0N	765.0000	327.0000	206.0000	94.0000	83.0000	73.0000	68.0000	95.0
K0S	826.0000	354.0000	221.0000	101.0000	87.0000	76.0000	70.0000	96.0

# 6.3.12 Type V 230 – Standard bevel gearboxes

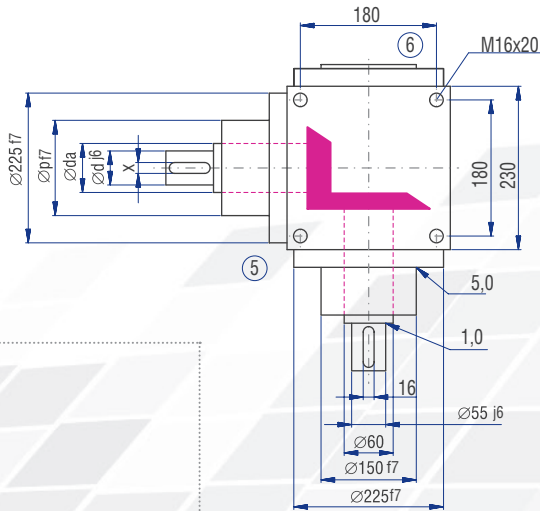
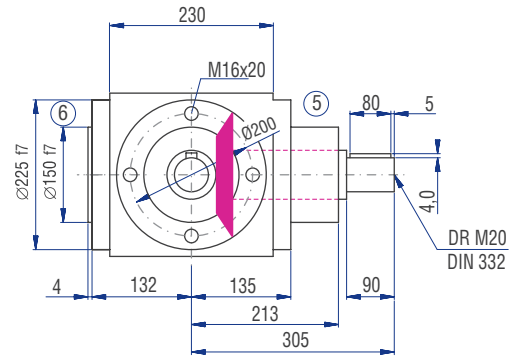
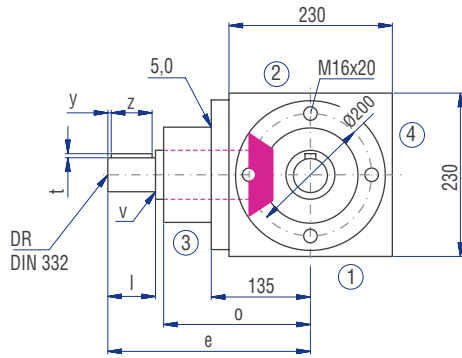
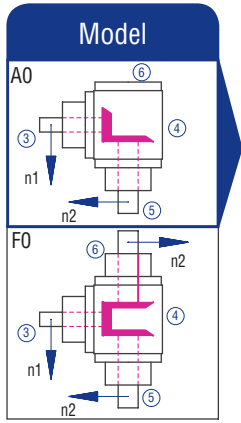

	Gear ratio						
	1:1	1.5:1	2:1	3:1	4:1	5:1	6:1
<b>d [mm]</b>	55	55	55	40	40	35	35
<b>da [mm]</b>	60	60	60	50	50	45	45
<b>l [mm]</b>	90	90	90	80	80	70	70
<b>v [mm]</b>	1	1	1	1	1	1	1
<b>x [mm]</b>	16	16	16	12	12	10	10
<b>y [mm]</b>	5	5	5	5	5	3	3
<b>z [mm]</b>	80	80	80	70	70	63	63
<b>t [mm]</b>	2.5	2.5	2.5	3	3	3	3
<b>e [mm]</b>	305	305	305	310	310	300	300
<b>o [mm]</b>	213	213	213	228	228	228	228
<b>p [mm]</b>	150	150	150	140	140	140	140
<b>DR M</b>	20	20	20	16	16	16	16

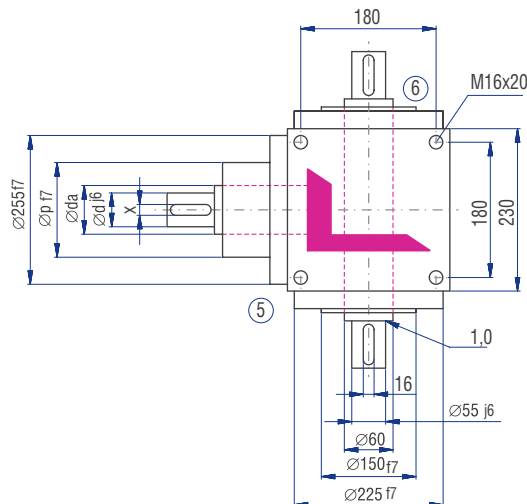
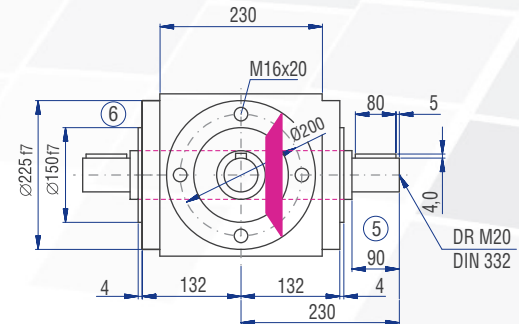
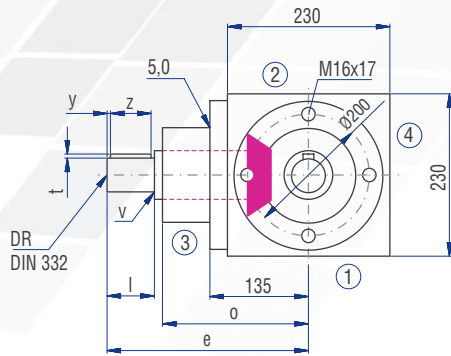
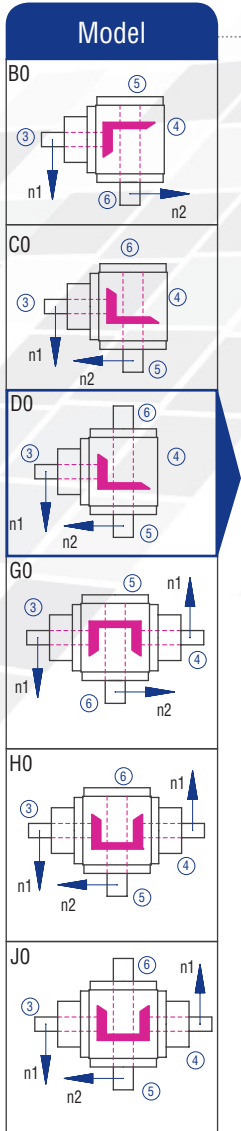

## Implementation WV

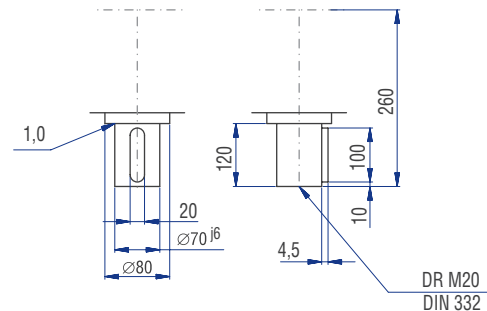

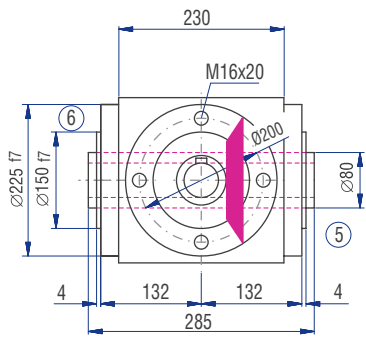
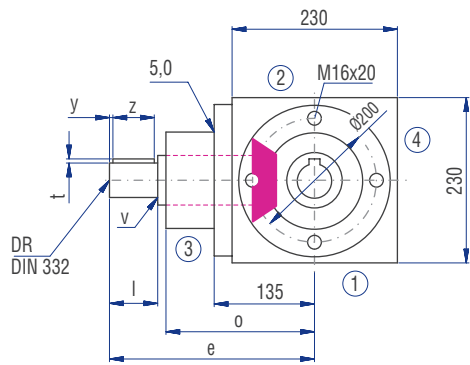

Implementation

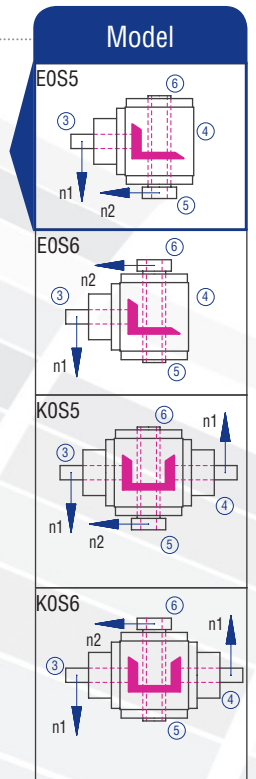
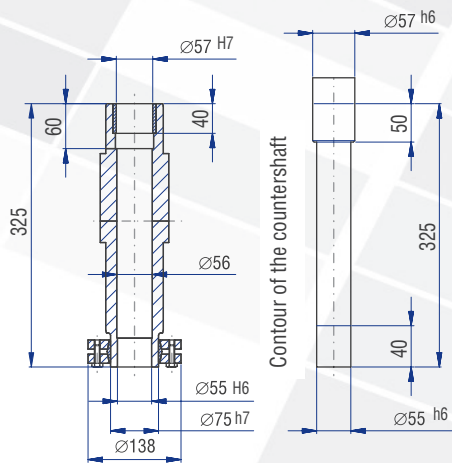
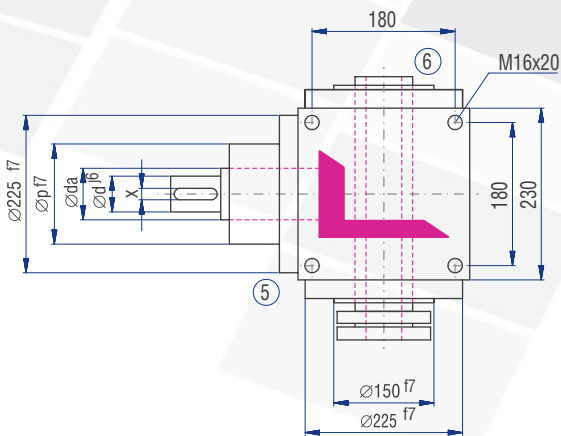
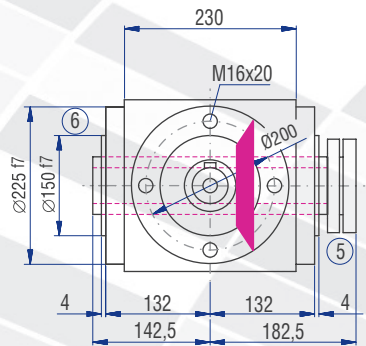
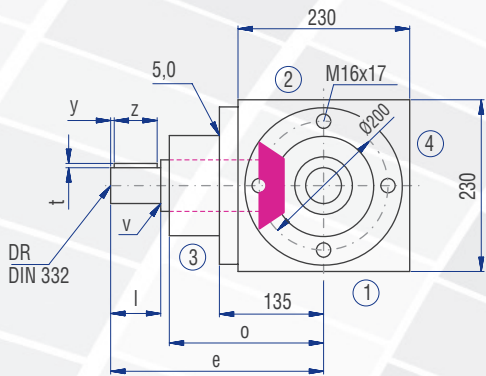
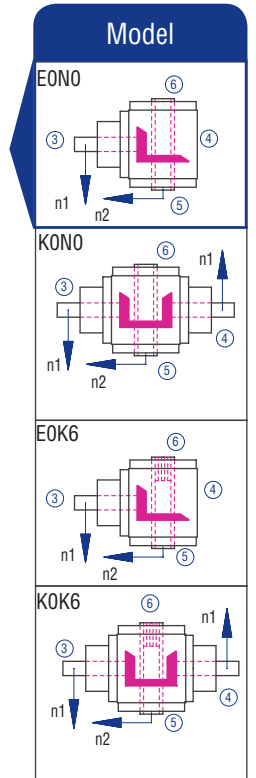
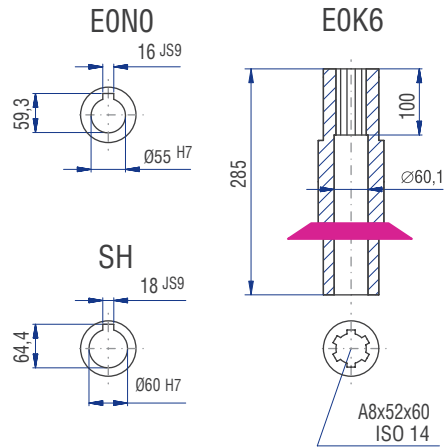
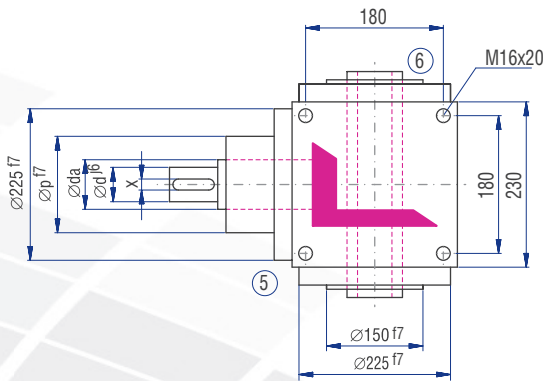

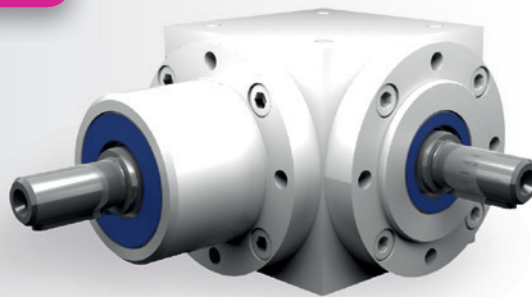

### Characteristics

Characteristic	Standard	Option
<b>Toothing</b>	Spiral toothed bevel gear set	See chapter 6.2.1
<b>Gear ratio</b>	1:1 to 6:1	
<b>Housing / Flanges</b>	Grey cast iron; steel	
<b>Threaded mounting hole</b>	On all housing surfaces without flange and on all flanges.	See chapter 6.2.3
<b>Shaft</b>	Material 1 C45, shaft ends greased Fit with ISO 6 tolerance with parallel keyway: according to DIN 6885 Sheet 1	See chapter 4.6.2
<b>Hollow shaft</b>	Material 1 C45, shafts greased Fit with ISO 7 tolerance with parallel keyway: according to DIN 6885 Sheet 1	See chapter 4.6.3
<b>Radial shaft seal ring</b>	NBR, form A	See chapter 4.8
<b>Ambient temperature</b>	-10°C to +90°C. The values of the performance tables are valid for +20°C	See chapter 4.9.3
<b>Circumferential backlash</b>	< 30 arcmin	See chapter 6.2.10
<b>Protection class</b>	IP 54	See chapter 4.5
<b>Corrosion protection</b>	Prime coat; layer thickness > 40 µm	See chapter 4.4.1
<b>Bearing life L10h</b>	more than 15,000h	See chapter 4.9.1
<b>Oil change intervals</b>	Not required if the oil temperature is kept < 90°C The lifetime of the bearings can be increased by the factor 1.5 if the oil is changed after the first 500 service hours and then every 5000 service hours.	See chapter 6.2.8
<b>Lubricant</b>	Synthetic lubricants	See chapter 6.2.8

## Performance data

$n_1$ [rpm]	1:1		1.5:1			2:1			3:1			4:1			5:1			6:1			
	$n_2$ [rpm]	$P_{1N}$ [kW]	$T_{2N}$ [Nm]	$n_2$ [rpm]	$P_{1N}$ [kW]	$T_{2N}$ [Nm]	$n_2$ [rpm]	$P_{1N}$ [kW]	$T_{2N}$ [Nm]	$n_2$ [rpm]	$P_{1N}$ [kW]	$T_{2N}$ [Nm]	$n_2$ [rpm]	$P_{1N}$ [kW]	$T_{2N}$ [Nm]	$n_2$ [rpm]	$P_{1N}$ [kW]	$T_{2N}$ [Nm]	$n_2$ [rpm]	$P_{1N}$ [kW]	$T_{2N}$ [Nm]
3000				2000	189.58	860	1500	133.92	810	1000	85.97	780	750	57.87	700	600	46.29	700	500	27.27	495
2400				1600	158.72	900	1200	112.43	850	800	72.39	821	600	51.58	780	480	40.21	760	400	23.12	524
1500	1500	157.07	950	1000	104.71	950	750	78.53	950	500	49.60	900	375	37.20	900	300	29.10	880	250	16.36	594
1000	1000	115.73	1,050	667	77.19	1,050	500	57.87	1,050	333	36.34	990	250	28.93	1,050	200	21.82	990	167	12.93	702
750	750	96.72	1,170	500	64.48	1,170	375	48.36	1,170	250	28.93	1,050	188	22.73	1,100	150	18.19	1,100	125	10.91	792
500	500	72.75	1,320	333	47.72	1,300	250	35.27	1,280	167	20.43	1,110	125	16.26	1,180	100	13.23	1,200	83	8.06	878
250	250	42.44	1,540	167	27.43	1,490	125	20.12	1,460	83	11.16	1,220	63	8.61	1,250	50	7.11	1,290	42	4.35	940
50	50	9.64	1,750	33	6.18	1,700	25	4.55	1,650	17	2.55	1,360	13	1.82	1,320	10	1.47	1,330	8	0.87	951
$P_{1Nt}$ [kW]	42.0			42.0			42.0			42.0			42.0			42.0					
$T_{2max}$ [Nm]	2310			2100			2100			1940			1940			1910			1730		

### Permissible radial force $F_{r1}$ and axial force $F_{a1}$ on shaft $N_1$

$n_1$ [rpm]	3000		1000		500		250		100		50	
$T_2$ [Nm]	$F_r$ [N]	$F_a$ [N]	$F_r$ [N]	$F_a$ [N]	$F_r$ [N]	$F_a$ [N]	$F_r$ [N]	$F_a$ [N]	$F_r$ [N]	$F_a$ [N]	$F_r$ [N]	$F_a$ [N]
< 950	7000	3500	8600	4300	11200	5600	15000	7500	17500	8750	20000	10000
> 950	5830	2915	7170	3585	9330	4665	12500	6250	14580	7290	16670	8335

### Permissible radial force $F_{r2}$ and axial force $F_{a2}$ on shaft $N_2$

$n_2$ [rpm]	3000		1000		500		250		100		50	
$T_2$ [Nm]	$F_r$ [N]	$F_a$ [N]	$F_r$ [N]	$F_a$ [N]	$F_r$ [N]	$F_a$ [N]	$F_r$ [N]	$F_a$ [N]	$F_r$ [N]	$F_a$ [N]	$F_r$ [N]	$F_a$ [N]
< 950	8500	4250	13000	6500	16000	8000	18000	9000	22000	11000	28000	14000
> 950	7080	3540	10830	5415	13330	6665	15000	7500	18330	9165	23330	11665

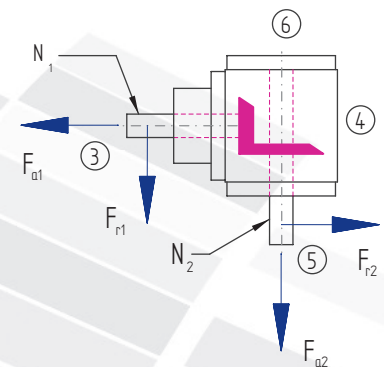

### Inertia moments/mass

Inertia moment  $J_1$  related to the fast-rotating shaft ( $N_1$ )

Model	Inertia moment [kgcm <sup>2</sup> ]							Mass [kg]
	1:1	1.5:1	2:1	3:1	4:1	5:1	6:1	
A0	814.200	305.933	194.275	85.0833	46.7738	37.2840	31.8083	85.0
B0	827.440	168.262	281.335	117.221	66.6638	50.0136	40.7039	85.0
C0	827.440	168.262	281.335	117.221	66.6638	50.0136	40.7039	85.0
D0	841.850	383.556	284.938	52.2667	67.5644	50.5900	41.1042	88.0
E0N	828.690	413.262	287.898	120.110	68.2888	51.0536	41.4261	82.0
E0S	892.340	441.551	303.810	127.180	72.2656	53.5988	43.1936	84.9
F0	1221.300	486.867	296.050	130.317	72.2175	53.5680	43.1167	105.0
G0	1234.540	293.262	373.835	157.071	87.9938	71.0136	61.2039	109.0
H0	1234.540	293.262	373.835	157.071	87.9938	71.0136	61.2039	109.0
J0	1248.950	508.556	377.438	92.1167	88.8944	71.5900	61.6042	112.0
K0N	1235.790	538.262	380.398	159.960	89.6188	72.0536	61.9261	106.0
K0S	1299.440	566.551	396.310	167.030	93.5956	74.5988	63.6936	108.9

# 6.3.13 Type V 260 – Standard bevel gearboxes

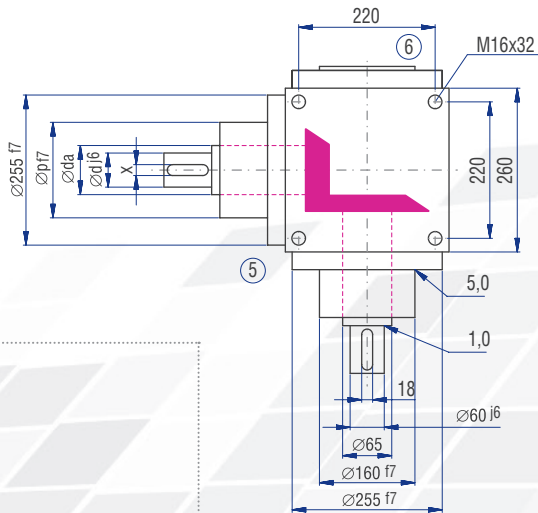
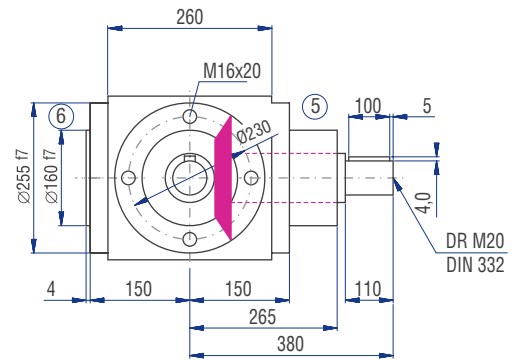
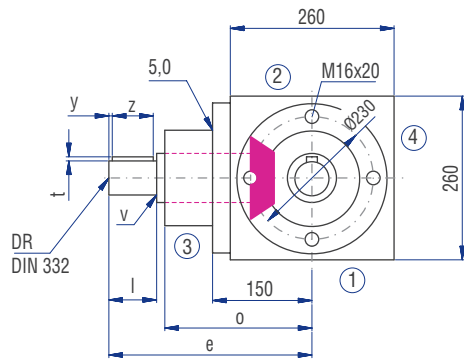
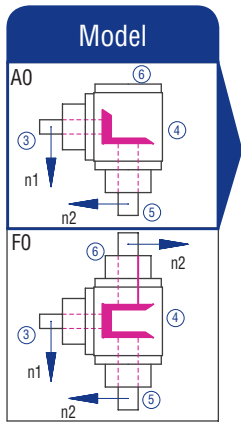

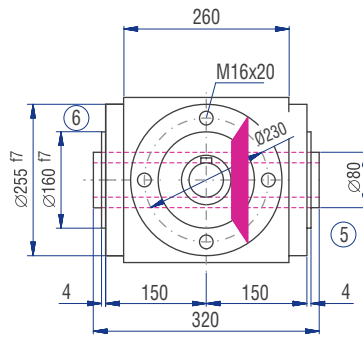
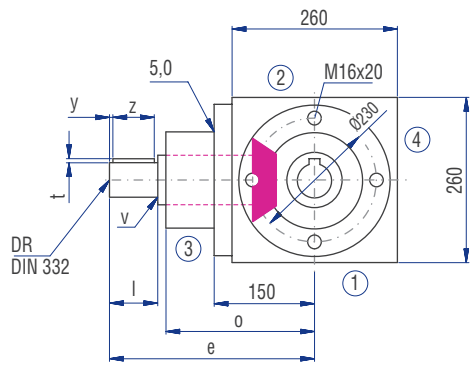

### Implementation

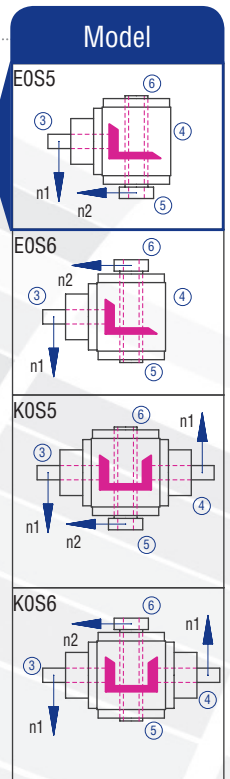
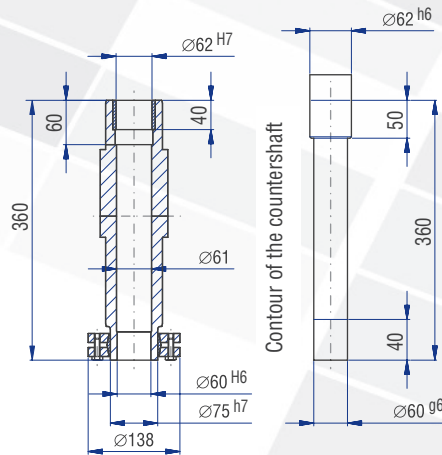
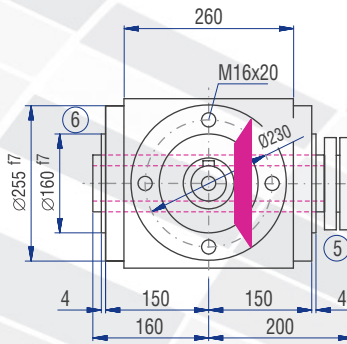
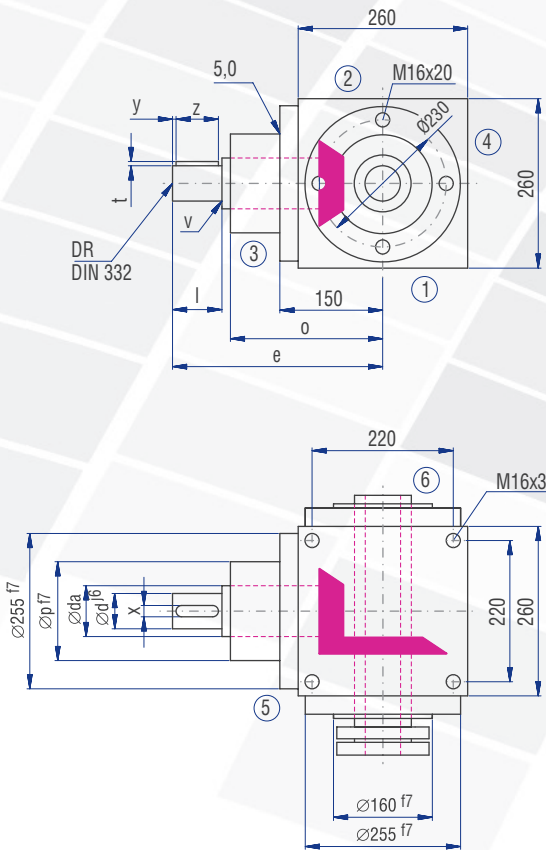
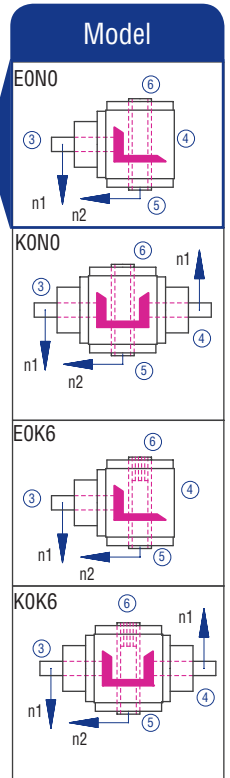
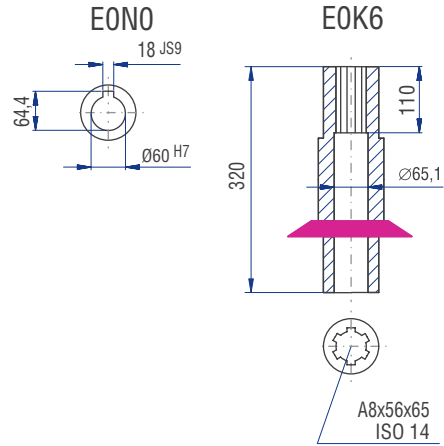
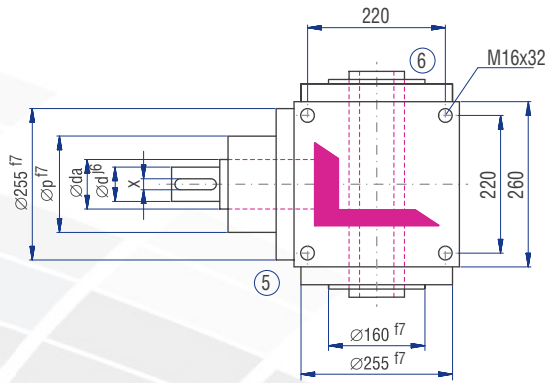

## 6.3.14 Standard bevel gearboxes – Type V 350

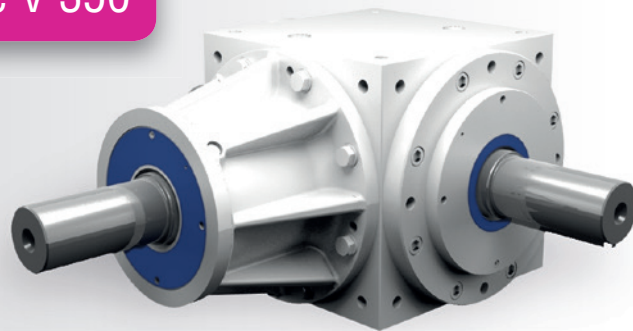

### Characteristics

Characteristic	Standard	Option
<b>Toothing</b>	Spiral toothed bevel gear set	See chapter 6.2.1
<b>Gear ratio</b>	1:1 to 6:1	
<b>Housing / Flanges</b>	Grey cast iron; steel	
<b>Threaded mounting hole</b>	On all housing surfaces without flange and on all flanges.	See chapter 6.2.3
<b>Shaft</b>	Material 1 C45, shaft ends greased Fit with ISO 6 tolerance with parallel keyway: according to DIN 6885 Sheet 1	See chapter 4.6.2
<b>Hollow shaft</b>	Material 1 C45, shafts greased Fit with ISO 7 tolerance with parallel keyway: according to DIN 6885 Sheet 1	See chapter 4.6.3
<b>Radial shaft seal ring</b>	NBR, form A	See chapter 4.8
<b>Ambient temperature</b>	-10°C to +90°C. The values of the performance tables are valid for +20°C	See chapter 4.9.3
<b>Circumferential backlash</b>	< 30 arcmin	See chapter 6.2.10
<b>Protection class</b>	IP 54	See chapter 4.5
<b>Corrosion protection</b>	Prime coat; layer thickness > 40 µm	See chapter 4.4.1
<b>Bearing life L10h</b>	more than 15,000h	See chapter 4.9.1
<b>Oil change intervals</b>	Not required if the oil temperature is kept < 90°C The lifetime of the bearings can be increased by the factor 1.5 if the oil is changed after the first 500 service hours and then every 5000 service hours.	See chapter 6.2.8
<b>Lubricant</b>	Synthetic lubricants	See chapter 6.2.8

## Performance data

n <sub>1</sub> [rpm]	1:1			1.5:1			2:1			3:1			4:1			5:1			6:1			
	n <sub>2</sub> [rpm]	P <sub>1N</sub> [kW]	T <sub>2N</sub> [Nm]	n <sub>2</sub> [rpm]	P <sub>1N</sub> [kW]	T <sub>2N</sub> [Nm]	n <sub>2</sub> [rpm]	P <sub>1N</sub> [kW]	T <sub>2N</sub> [Nm]	n <sub>2</sub> [rpm]	P <sub>1N</sub> [kW]	T <sub>2N</sub> [Nm]	n <sub>2</sub> [rpm]	P <sub>1N</sub> [kW]	T <sub>2N</sub> [Nm]	n <sub>2</sub> [rpm]	P <sub>1N</sub> [kW]	T <sub>2N</sub> [Nm]	n <sub>2</sub> [rpm]	P <sub>1N</sub> [kW]	T <sub>2N</sub> [Nm]	
2400										800	160.48	1,820	600	113.75	1,720	480	78.83	1,490	400	56.88	1,290	
1500	1500	267.84	1,620	1000	206.19	1,870	750	200.06	2,420	500	122.35	2,220	375	78.95	1,910	300	56.54	1,710	250	41.61	1,510	
1000	1000	210.53	1,910	667	188.55	2,560	500	155.41	2,820	333	96.26	2,620	250	58.14	2,110	200	42.33	1,920	167	31.41	1,710	
750	750	195.92	2,370	500	141.42	2,560	375	129.37	3,130	250	81.29	2,950	188	47.95	2,320	150	35.88	2,170	125	24.25	1,760	
500	500	155.41	2,820	333	112.63	3,070	250	94.52	3,430	167	59.34	3,230	125	34.72	2,520	100	26.67	2,420	83	16.72	1,820	
250	250	94.52	3,440	167	67.11	3,650	125	54.15	3,930	83	34.26	3,730	63	19.43	2,820	50	16.09	2,920	42	9.28	2,020	
50	50	24.47	4,440	33	16.34	4,500	25	12.79	4,640	17	7.79	4,240	13	4.17	3,030	10	3.56	3,230	8	1.95	2,120	
P <sub>1Nt</sub> [kW]		90.0			90.0			90.0			90.0			90.0			90.0			90.0		
T <sub>2max</sub> [Nm]		5400			5200			5000			4500			3500			3500			2300		

### Permissible radial force F<sub>r1</sub> and axial force F<sub>a1</sub> on shaft N<sub>1</sub>

n <sub>1</sub> [rpm]	3000		1000		500		250		100		50	
T <sub>2</sub> [Nm]	F <sub>r</sub> [N]	F <sub>a</sub> [N]	F <sub>r</sub> [N]	F <sub>a</sub> [N]	F <sub>r</sub> [N]	F <sub>a</sub> [N]	F <sub>r</sub> [N]	F <sub>a</sub> [N]	F <sub>r</sub> [N]	F <sub>a</sub> [N]	F <sub>r</sub> [N]	F <sub>a</sub> [N]
< 2400	14500	7250	15000	7500	17500	8750	22500	11250	27500	13750	33000	16500
> 2400	12000	6000	12500	6250	14500	7250	18700	9350	23000	11500	27500	13750

### Permissible radial force F<sub>r2</sub> and axial force F<sub>a2</sub> on shaft N<sub>2</sub>

n <sub>2</sub> [rpm]	3000		1000		500		250		100		50	
T <sub>2</sub> [Nm]	F <sub>r</sub> [N]	F <sub>a</sub> [N]	F <sub>r</sub> [N]	F <sub>a</sub> [N]	F <sub>r</sub> [N]	F <sub>a</sub> [N]	F <sub>r</sub> [N]	F <sub>a</sub> [N]	F <sub>r</sub> [N]	F <sub>a</sub> [N]	F <sub>r</sub> [N]	F <sub>a</sub> [N]
< 2400	17500	8750	18100	9050	21100	10550	26150	13075	34200	17100	40200	20100
> 2400	14500	7250	15080	7540	17580	8790	21790	10895	28500	14250	33500	16750

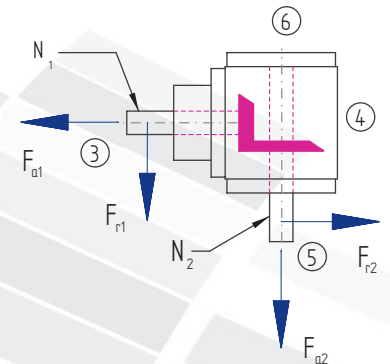

### Inertia moments/mass

Inertia moment J<sub>1</sub> related to the fast-rotating shaft (N<sub>1</sub>)

Model	Inertia moment [kgcm <sup>2</sup> ]							Mass [kg]
	1:1	1.5:1	2:1	3:1	4:1	5:1	6:1	
A0	3388.00	1707.00	1021.00	585.000	473.000	296.000	261.000	269.0
B0	3634.00	1793.00	1063.00	605.000	485.000	304.000	266.000	280.0
C0	3634.00	1793.00	1063.00	605.000	485.000	304.000	266.000	280.0
D0	3699.00	1822.00	1079.00	612.000	489.000	306.000	268.000	287.0
E0N	3459.00	1716.00	1019.00	586.000	474.000	297.000	262.000	259.0
E0S	3694.00	1820.00	1078.00	612.000	489.000	306.000	268.000	264.0
F0	5082.00	2593.00	1573.00	805.000	606.000	386.000	317.000	340.0
G0	5328.00	2613.00	1533.00	969.000	825.000	511.000	471.000	372.0
H0	5328.00	2613.00	1533.00	969.000	825.000	511.000	471.000	372.0
J0	5393.00	2642.00	1549.00	976.000	829.000	513.000	473.000	379.0
K0N	5153.00	2536.00	1489.00	950.000	814.000	504.000	467.000	351.0
K0S	5388.00	2640.00	1548.00	976.000	829.000	513.000	473.000	356.0

# 6.3.14 Standard bevel gearboxes – Type V 350

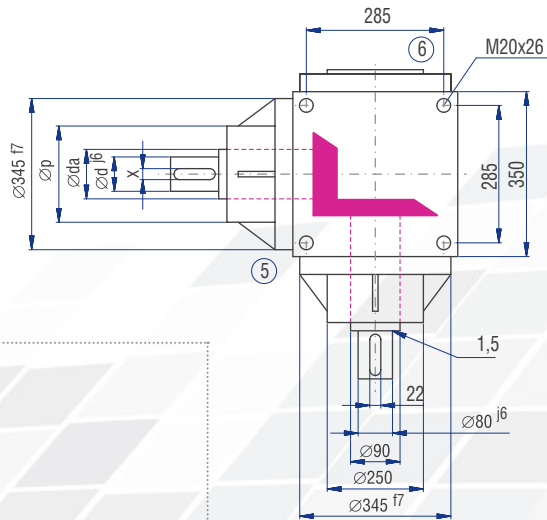
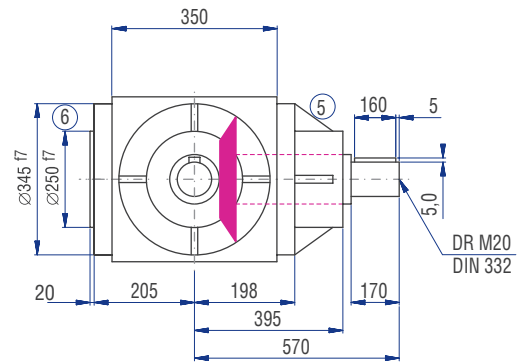
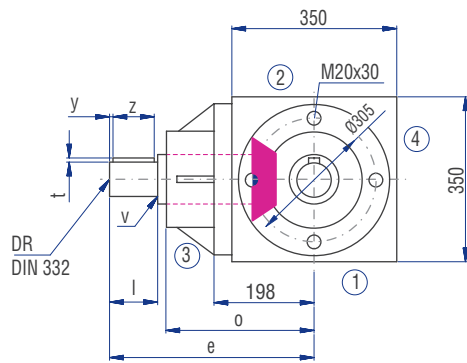
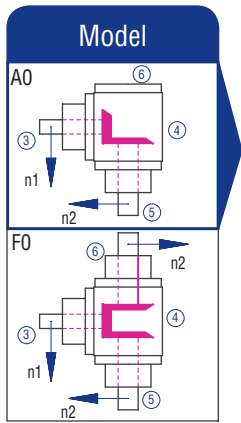

	Gear ratio						
	1:1	1.5:1	2:1	3:1	4:1	5:1	6:1
d [mm]	80	80	80	65	65	55	55
da [mm]	90	90	90	90	90	72	72
l [mm]	170	170	170	140	140	110	110
v [mm]	1.5	1.5	1.5	1.5	1.5	1.5	1.5
x [mm]	22	22	22	18	18	16	16
y [mm]	5	5	5	7.5	7.5	10	10
z [mm]	160	160	160	125	125	90	90
t [mm]	5	5	5	4	4	4	4
e [mm]	570	570	570	540	540	510	510
o [mm]	395	395	395	395	395	395	395
p [mm]	250	250	250	250	250	250	250
DR M	20	20	20	20	20	20	20

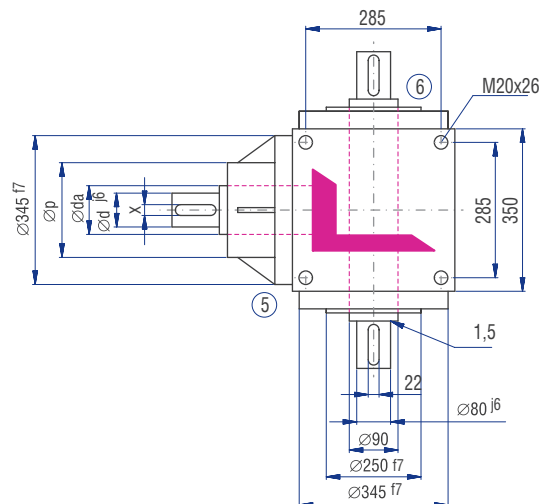
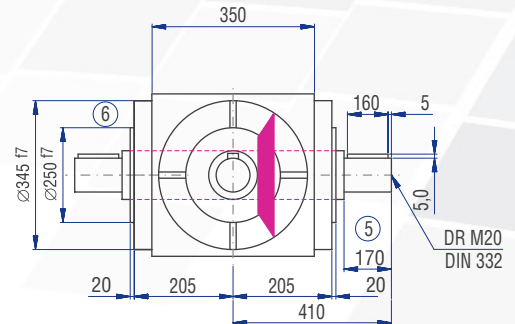
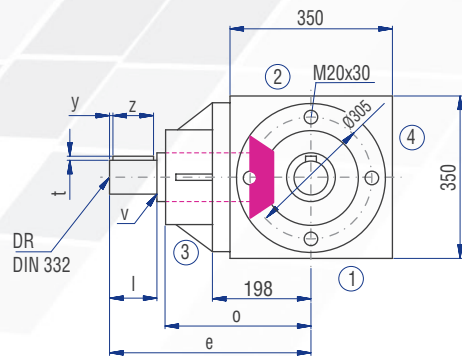
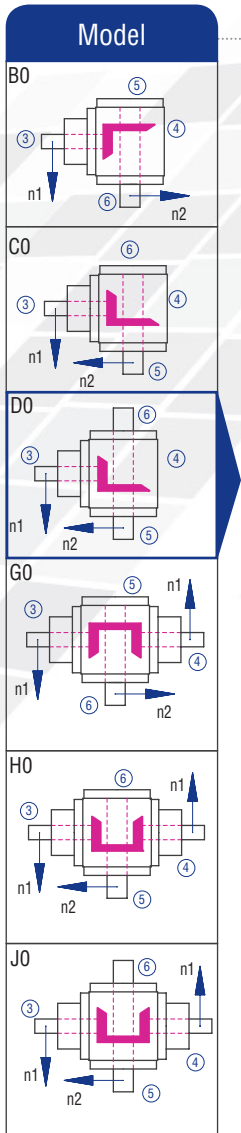

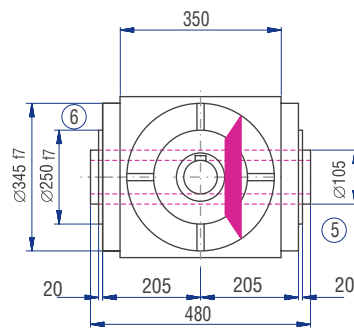
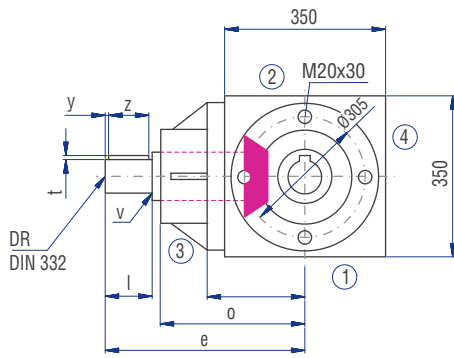

### Implementation

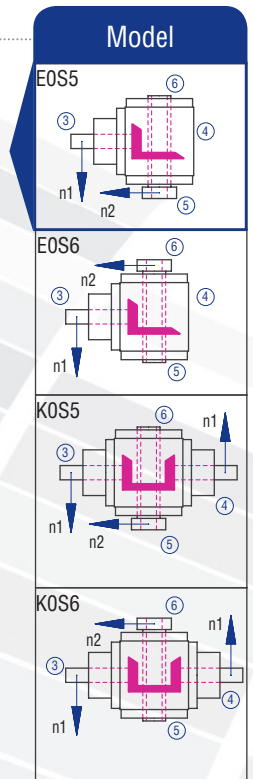
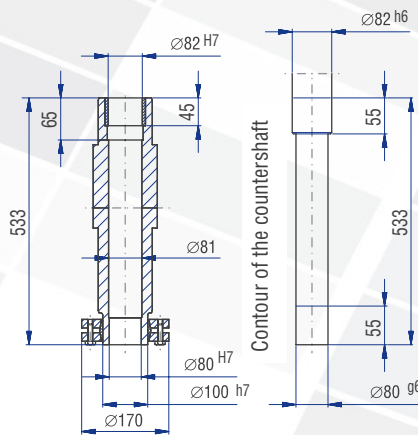
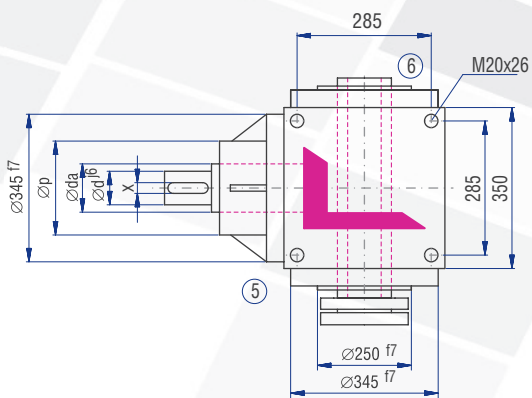
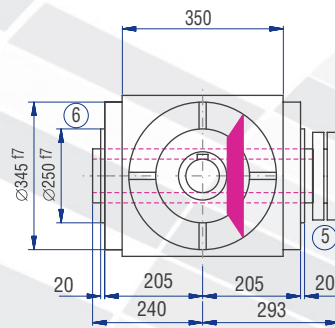
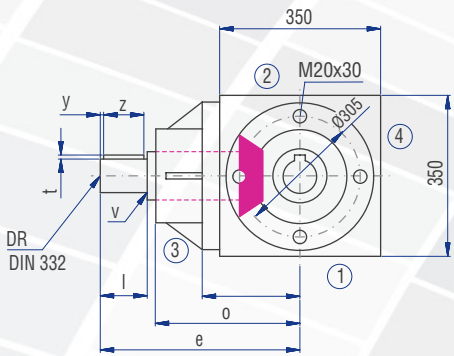
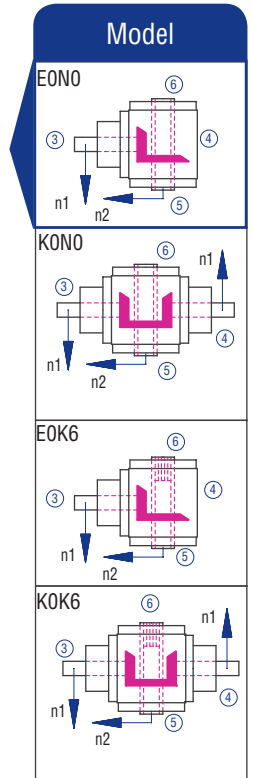
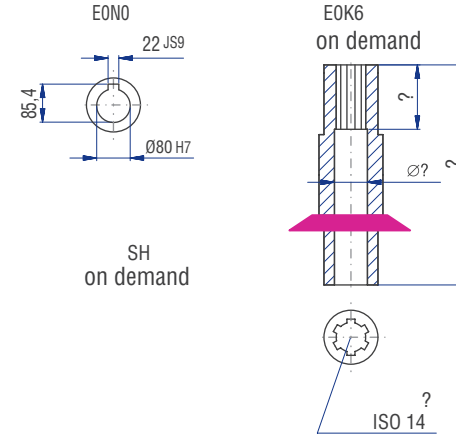
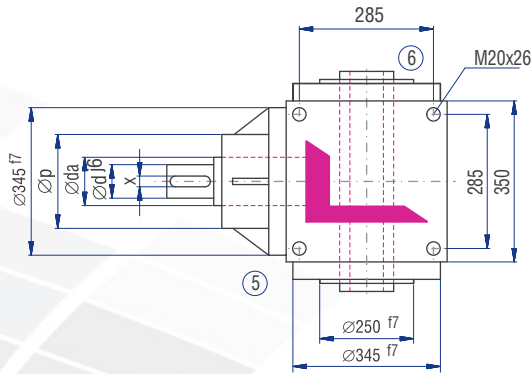

# 6.4 Type VS – Type V with step-up ratio

## 6.4.1 Features

Gear ratios:  $i = 1:1.5$  to  $1:2$   
 Maximum output torque: 1200 Nm  
 7 gearbox sizes with edge lengths of 090 to 260 mm  
 Larger shaft diameter ( $N_2$ ), slowly rotating  
 Low-backlash construction < 10 angular minutes possible  
 Housing made of grey cast iron or steel

The through-shaft ( $N_1$ ) is fast-running

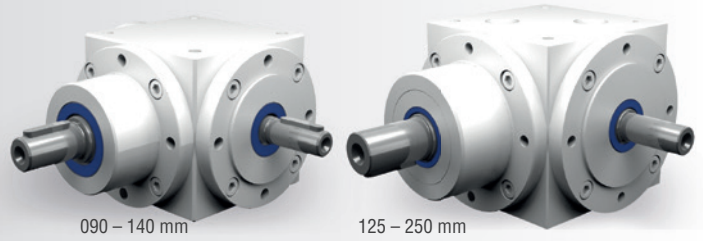

## 6.4.2 Models

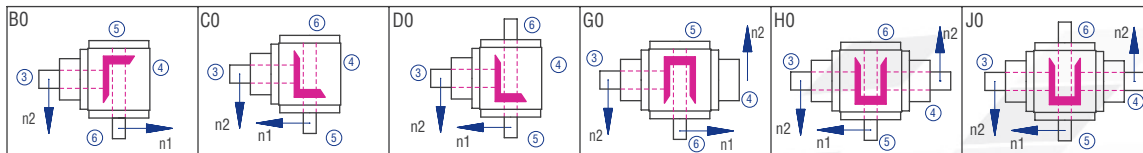

Figure 6.4.2-1; Models

## 6.4.3 Gearbox sides

The example shows the Model C0

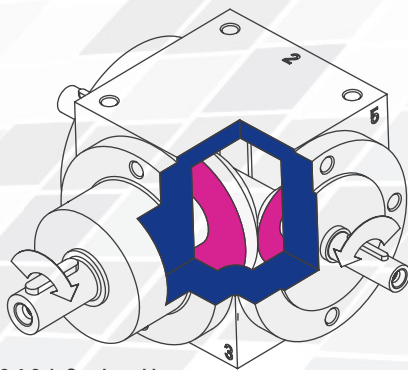

Figure 6.4.3-1; Gearbox sides

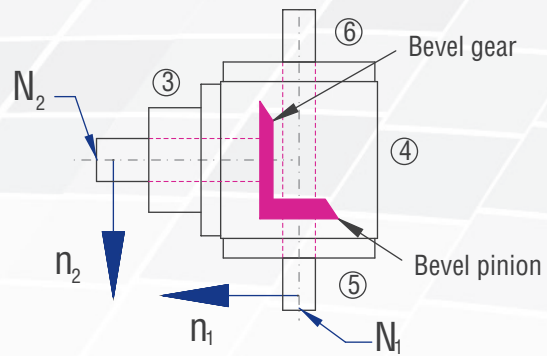

Figure 6.4.3-2; Shaft designations

## 6.4.4 Order code

The order code reflects the customer specifications. Example:

Type	Size	Gear ratio	Model	Fixing side	Installation position	Speed $n_2$	Design
VS	090	1.5:1	C0-	1.	1-	1500	/0000
<b>Description</b>	Housing; Table 6.4.5-1	Table 6.4.5-1	Figure 6.4.2-1; Models	Gearbox side on which fixing is made Table 6.2.3-1; Figure 4.3.1-1; Gear- box sides	Gearbox side directed down- wards; Figure 4.3.1-1; Gearbox sides	Slowly rotating shaft; Table 6.4.5-1	Standard

Table 6.4.4-1

## 6.4.5 Overview of performance data

Size	1.5:1				2:1		
	n <sub>1</sub> [rpm]	n <sub>2</sub> [rpm]	P <sub>1N</sub> [kW]	T <sub>2N</sub> [Nm]	n <sub>2</sub> [rpm]	P <sub>1N</sub> [kW]	T <sub>2N</sub> [Nm]
090	3000	2000	5.51	25	1500	3.80	23
	2400	1600	4.59	26	1200	3.17	24
	1500	1000	3.20	29	750	2.23	27
	1000	667	2.35	32	500	1.65	30
	750	500	1.93	35	375	1.24	30
	500	333	1.36	37	250	0.82	30
	250	167	0.74	40	125	0.41	30
	50	33	0.15	40	25	0.08	30
120	3000	2000	13.45	61	1500	9.26	56
	2400	1600	11.46	65	1200	8.07	61
	1500	1000	8.60	78	750	6.03	73
	1000	667	6.32	86	500	4.40	80
	750	500	5.18	94	375	3.30	80
	500	333	3.70	100	250	2.20	80
	250	167	1.84	100	125	1.10	80
	50	33	0.37	100	25	0.22	80
140	3000	2000	24.91	113	1500	16.53	100
	2400	1600	22.22	126	1200	14.68	111
	1500	1000	17.08	155	750	11.41	138
	1000	667	12.87	175	500	8.38	152
	750	500	10.47	190	375	6.86	166
	500	333	7.34	200	250	4.96	180
	250	167	3.76	204	125	2.48	180
	50	33	0.76	210	25	0.50	180
160	3000	2000	40.78	185	1500	28.11	170
	2400	1600	36.15	205	1200	25.53	193
	1500	1000	27.78	252	750	20.25	245
	1000	667	20.59	280	500	14.88	270
	750	500	16.26	295	375	11.57	280
	500	333	11.56	315	250	8.27	300
	250	167	6.07	330	125	4.41	320
	50	33	1.29	355	25	0.88	320
200	3000	2000	72.75	330	1500	51.25	310
	2400	1600	63.49	360	1200	45.24	342
	1500	1000	48.17	437	750	35.13	425
	1000	667	37.13	505	500	27.56	500
	750	500	30.31	550	375	21.90	530
	500	333	22.02	600	250	14.60	530
	250	167	11.04	600	125	7.30	530
	50	33	2.18	600	25	1.46	530
230	3000	2000	99.20	450	1500	87.63	530
	2400	1600	91.35	518	1200	80.02	605
	1500	1000	72.20	655	750	59.11	715
	1000	667	56.21	765	500	45.19	820
	750	500	45.47	825	375	36.79	890
	500	333	33.79	920	250	26.73	970
	250	167	20.57	1120	125	16.88	1225
	50	33	4.89	1330	25	3.66	1330
260	3000	2000	189.58	860	1500	133.92	810
	2400	1600	158.72	900	1200	112.43	850
	1500	1000	104.71	950	750	78.53	950
	1000	667	73.50	1000	500	57.87	1050
	750	500	55.11	1000	375	48.36	1170
	500	333	36.70	1000	250	33.07	1200
	250	167	18.40	1000	125	16.53	1200
	50	33	3.64	1000	25	3.31	1200

Table 6.4.5-1

## 6.4.6 Type VS 090 – Type V with step-up ratio

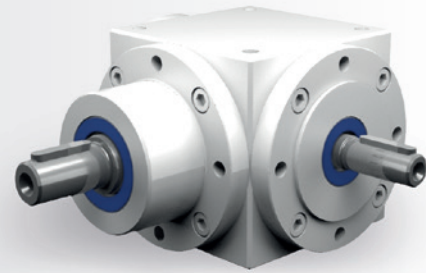

### Characteristics

Characteristic	Standard	Option
Toothing	Bevel gear set, spiral-toothed	See chapter 6.2.1
Gear ratio	1.5:1 to 2:1	
Housing / Flanges	Grey cast iron; steel	
Threaded mounting holes	On all housing surfaces without flange and on all flanges.	See chapter 6.2.3
Shaft	Material 1 C45, shaft ends greased Fit with ISO 6 tolerance with parallel keyway: according to DIN 6885 Sheet 1	See chapter 4.6.2
Hollow shaft	Not deliverable	
Radial shaft seal ring	NBR, form A	See chapter 4.8
Ambient temperature	-10°C to +90°C. The values of the performance tables are valid for +20°C	See chapter 4.9.3
Circumferential backlash	< 30 arcmin	See chapter 6.2.10
Protection class	IP 54	See chapter 4.5
Corrosion protection	Prime coat; layer thickness > 40 µm	See chapter 4.4.1
Bearing life L10h	more than 15,000h	See chapter 4.9.1
Oil change intervals	Not required if the oil temperature is kept < 90°C The lifetime of the bearings can be increased by the factor 1.5 if the oil is changed after the first 500 service hours and then every 5000 service hours.	See chapter 6.2.8
Lubricant	Synthetic lubricants	See chapter 6.2.8

### Performance data

n <sub>1</sub> [rpm]	1.5:1			2:1		
	n <sub>2</sub> [rpm]	P <sub>1N</sub> [kW]	T <sub>2N</sub> [Nm]	n <sub>2</sub> [rpm]	P <sub>1N</sub> [kW]	T <sub>2N</sub> [Nm]
3000	2000	5.51	25	1500	3.80	23
2400	1600	4.59	26	1200	3.17	24
1500	1000	3.20	29	750	2.23	27
1000	667	2.35	32	500	1.65	30
750	500	1.93	35	375	1.24	30
500	333	1.36	37	250	0.82	30
250	167	0.74	40	125	0.41	30
50	33	0.15	40	25	0.08	30
P <sub>1Nt</sub> [kW]	3.8			3.8		
T <sub>2max</sub> [Nm]	40			30		



## 6.4.7 Type VS 120 – Type V with step-up ratio

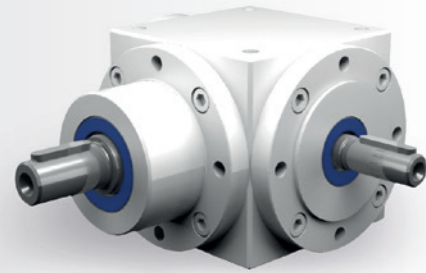

### Characteristics

Characteristic	Standard	Option
Toothing	Bevel gear set, spiral-toothed	See chapter 6.2.1
Gear ratio	1.5:1 to 2:1	
Housing / Flanges	Grey cast iron; steel	
Threaded mounting holes	On all housing surfaces without flange and on all flanges.	See chapter 6.2.3
Shaft	Material 1 C45, shaft ends greased Fit with ISO 6 tolerance with parallel keyway: according to DIN 6885 Sheet 1	See chapter 4.6.2
Hollow shaft	Not deliverable	
Radial shaft seal ring	NBR, form A	See chapter 4.8
Ambient temperature	-10°C to +90°C. The values of the performance tables are valid for +20°C	See chapter 4.9.3
Circumferential backlash	< 30 arcmin	See chapter 6.2.10
Protection class	IP 54	See chapter 4.5
Corrosion protection	Prime coat; layer thickness > 40 µm	See chapter 4.4.1
Bearing life L10h	more than 15,000h	See chapter 4.9.1
Oil change intervals	Not required if the oil temperature is kept < 90°C The lifetime of the bearings can be increased by the factor 1.5 if the oil is changed after the first 500 service hours and then every 5000 service hours.	See chapter 6.2.8
Lubricant	Synthetic lubricants	See chapter 6.2.8

### Performance data

n <sub>1</sub> [rpm]	1.5:1			2:1		
	n <sub>2</sub> [rpm]	P <sub>1N</sub> [kW]	T <sub>2N</sub> [Nm]	n <sub>2</sub> [rpm]	P <sub>1N</sub> [kW]	T <sub>2N</sub> [Nm]
3000	2000	13.45	61	1500	9.26	56
2400	1600	11.46	65	1200	8.07	61
1500	1000	8.60	78	750	6.03	73
1000	667	6.32	86	500	4.40	80
750	500	5.18	94	375	3.30	80
500	333	3.70	100	250	2.20	80
250	167	1.84	100	125	1.10	80
50	33	0.37	100	25	0.22	80
P <sub>1Nt</sub> [kW]	6.2			6.2		
T <sub>2max</sub> [Nm]	100			80		

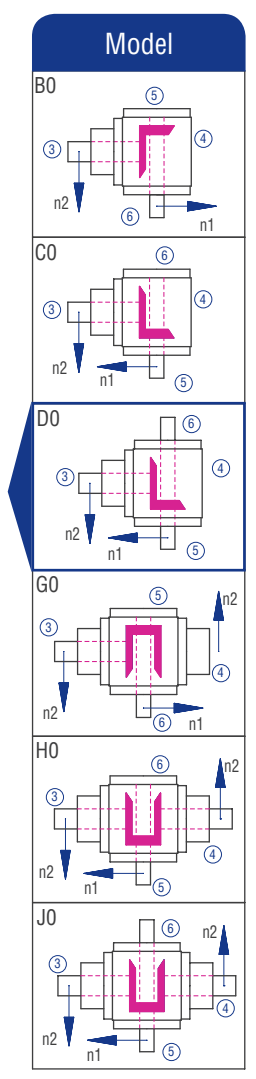
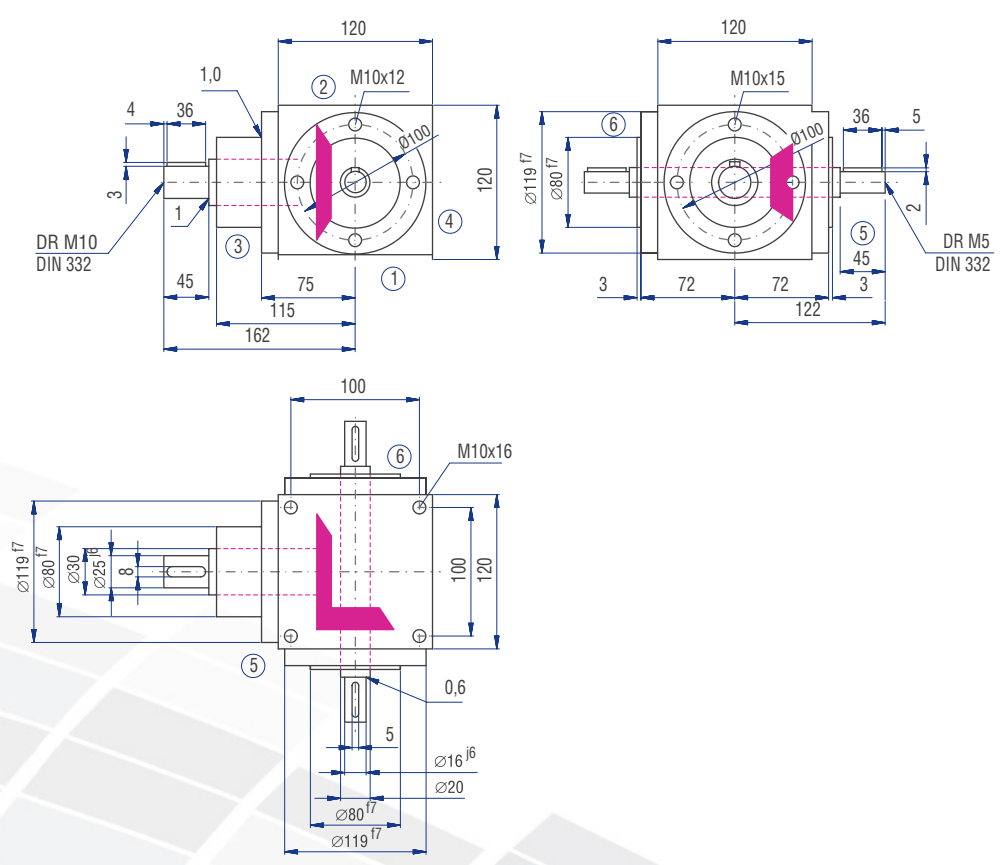

**Permissible radial force  $F_{r2}$  and axial force  $F_{a2}$  on shaft  $N_2$**

$n_2$ [rpm]	1500		1000		500		250		100		50	
$T_{2N}$ [Nm]	$F_r$ [N]	$F_a$ [N]	$F_r$ [N]	$F_a$ [N]	$F_r$ [N]	$F_a$ [N]	$F_r$ [N]	$F_a$ [N]	$F_r$ [N]	$F_a$ [N]	$F_r$ [N]	$F_a$ [N]
< 80	470	235	620	310	720	360	900	450	1150	575	1400	700
> 80	390	195	520	260	600	300	750	375	960	480	1170	585

**Permissible radial force  $F_{r1}$  and axial force  $F_{a1}$  on shaft  $N_1$**

$n_1$ [rpm]	3000		1000		500		250		100		50	
$T_{1N}$ [Nm]	$F_r$ [N]	$F_a$ [N]	$F_r$ [N]	$F_a$ [N]	$F_r$ [N]	$F_a$ [N]	$F_r$ [N]	$F_a$ [N]	$F_r$ [N]	$F_a$ [N]	$F_r$ [N]	$F_a$ [N]
< 60	580	290	770	385	960	480	1150	575	1460	730	1690	845
> 60	480	240	640	320	800	400	960	480	1220	610	1410	705

**Inertia moments/mass**

Inertia moment  $J_2$  related to the slowly rotating shaft ( $N_2$ )

Model	Inertia moment [kgcm <sup>2</sup> ]	
	1.5:1	2:1
B0	9.60000	9.80000
C0	9.60000	9.80000
D0	9.70000	9.90000
G0	16.30000	16.40000
H0	16.30000	16.40000
J0	16.40000	16.50000

Mass ca.[kg]
11.5
11.5
11.5
15.0
15.0
15.0

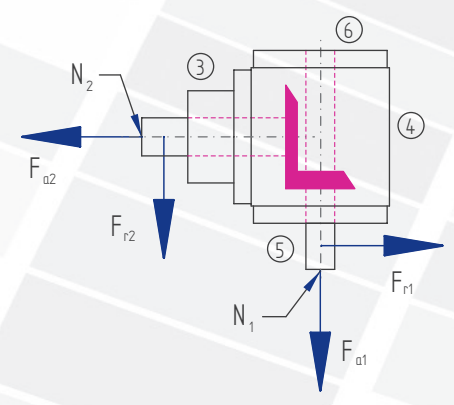

## 6.4.8 Type VS 140 – Type V with step-up ratio

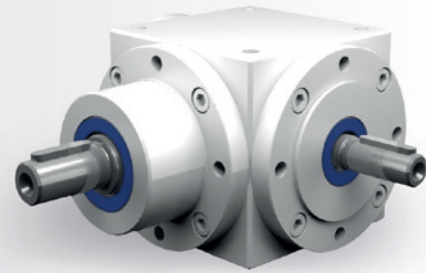

### Characteristics

Characteristic	Standard	Option
Toothing	Bevel gear set, spiral-toothed	See chapter 6.2.1
Gear ratio	1.5:1 to 2:1	
Housing / Flanges	Grey cast iron; steel	
Threaded mounting holes	On all housing surfaces without flange and on all flanges.	See chapter 6.2.3
Shaft	Material 1 C45, shaft ends greased Fit with ISO 6 tolerance with parallel keyway: according to DIN 6885 Sheet 1	See chapter 4.6.2
Hollow shaft	Not deliverable	
Radial shaft seal ring	NBR, form A	See chapter 4.8
Ambient temperature	-10°C to +90°C. The values of the performance tables are valid for +20°C	See chapter 4.9.3
Circumferential backlash	< 30 arcmin	See chapter 6.2.10
Protection class	IP 54	See chapter 4.5
Corrosion protection	Prime coat; layer thickness > 40 µm	See chapter 4.4.1
Bearing life L10h	more than 15,000h	See chapter 4.9.1
Oil change intervals	Not required if the oil temperature is kept < 90°C The lifetime of the bearings can be increased by the factor 1.5 if the oil is changed after the first 500 service hours and then every 5000 service hours.	See chapter 6.2.8
Lubricant	Synthetic lubricants	See chapter 6.2.8

### Performance data

n <sub>1</sub> [rpm]	1.5:1			2:1		
	n <sub>2</sub> [rpm]	P <sub>1N</sub> [kW]	T <sub>2N</sub> [Nm]	n <sub>2</sub> [rpm]	P <sub>1N</sub> [kW]	T <sub>2N</sub> [Nm]
3000	2000	24.91	113	1500	16.53	100
2400	1600	22.22	126	1200	14.68	111
1500	1000	17.08	155	750	11.41	138
1000	667	12.87	175	500	8.38	152
750	500	10.47	190	375	6.86	166
500	333	7.34	200	250	4.96	180
250	167	3.76	204	125	2.48	180
50	33	0.76	210	25	0.50	180
P <sub>1Nt</sub> [kW]	10.0			10.0		
T <sub>2max</sub> [Nm]	210			180		



## 6.4.9 Type VS 160 – Type V with step-up ratio

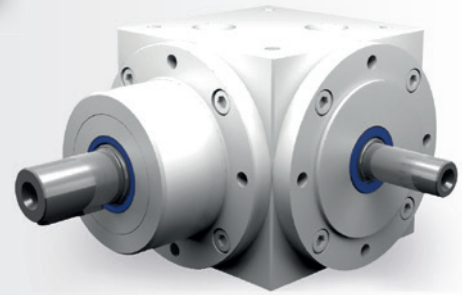

### Characteristics

Characteristic	Standard	Option
Toothing	Bevel gear set, spiral-toothed	See chapter 6.2.1
Gear ratio	1.5:1 to 2:1	
Housing / Flanges	Grey cast iron; steel	
Threaded mounting holes	On all housing surfaces without flange and on all flanges.	See chapter 6.2.3
Shaft	Material 1 C45, shaft ends greased Fit with ISO 6 tolerance with parallel keyway: according to DIN 6885 Sheet 1	See chapter 4.6.2
Hollow shaft	Not deliverable	
Radial shaft seal ring	NBR, form A	See chapter 4.8
Ambient temperature	-10°C to +90°C. The values of the performance tables are valid for +20°C	See chapter 4.9.3
Circumferential backlash	< 30 arcmin	See chapter 6.2.10
Protection class	IP 54	See chapter 4.5
Corrosion protection	Prime coat; layer thickness > 40 µm	See chapter 4.4.1
Bearing life L10h	more than 15,000h	See chapter 4.9.1
Oil change intervals	Not required if the oil temperature is kept < 90°C The lifetime of the bearings can be increased by the factor 1.5 if the oil is changed after the first 500 service hours and then every 5000 service hours.	See chapter 6.2.8
Lubricant	Synthetic lubricants	See chapter 6.2.8

### Performance data

n <sub>1</sub> [rpm]	1.5:1			2:1		
	n <sub>2</sub> [rpm]	P <sub>1N</sub> [kW]	T <sub>2N</sub> [Nm]	n <sub>2</sub> [rpm]	P <sub>1N</sub> [kW]	T <sub>2N</sub> [Nm]
3000	2000	40.78	185	1500	28.11	170
2400	1600	36.15	205	1200	25.53	193
1500	1000	27.78	252	750	20.25	245
1000	667	20.59	280	500	14.88	270
750	500	16.26	295	375	11.57	280
500	333	11.56	315	250	8.27	300
250	167	6.07	330	125	4.41	320
50	33	1.29	355	25	0.88	320
P <sub>1Nt</sub> [kW]	15.0			15.0		
T <sub>2max</sub> [Nm]	360			320		



## 6.4.10 Type VS 200 – Type V with step-up ratio

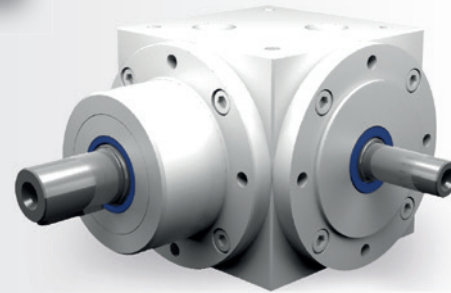

### Characteristics

Characteristic	Standard	Option
Toothing	Bevel gear set, spiral-toothed	See chapter 6.2.1
Gear ratio	1.5:1 to 2:1	
Housing / Flanges	Grey cast iron; steel	
Threaded mounting holes	On all housing surfaces without flange and on all flanges.	See chapter 6.2.3
Shaft	Material 1 C45, shaft ends greased Fit with ISO 6 tolerance with parallel keyway: according to DIN 6885 Sheet 1	See chapter 4.6.2
Hollow shaft	Not deliverable	
Radial shaft seal ring	NBR, form A	See chapter 4.8
Ambient temperature	-10°C to +90°C. The values of the performance tables are valid for +20°C	See chapter 4.9.3
Circumferential backlash	< 30 arcmin	See chapter 6.2.10
Protection class	IP 54	See chapter 4.5
Corrosion protection	Prime coat; layer thickness > 40 µm	See chapter 4.4.1
Bearing life L10h	more than 15,000h	See chapter 4.9.1
Oil change intervals	Not required if the oil temperature is kept < 90°C The lifetime of the bearings can be increased by the factor 1.5 if the oil is changed after the first 500 service hours and then every 5000 service hours.	See chapter 6.2.8
Lubricant	Synthetic lubricants	See chapter 6.2.8

### Performance data

n <sub>1</sub> [rpm]	1.5:1			2:1		
	n <sub>2</sub> [rpm]	P <sub>1N</sub> [kW]	T <sub>2N</sub> [Nm]	n <sub>2</sub> [rpm]	P <sub>1N</sub> [kW]	T <sub>2N</sub> [Nm]
3000	2000	72.75	330	1500	51.25	310
2400	1600	63.49	360	1200	45.24	342
1500	1000	48.17	437	750	35.13	425
1000	667	37.13	505	500	27.56	500
750	500	30.31	550	375	21.90	530
500	333	22.02	600	250	14.60	530
250	167	11.04	600	125	7.30	530
50	33	2.18	600	25	1.46	530
P <sub>1Nt</sub> [kW]	26.0			26.0		
T <sub>2max</sub> [Nm]	600			530		

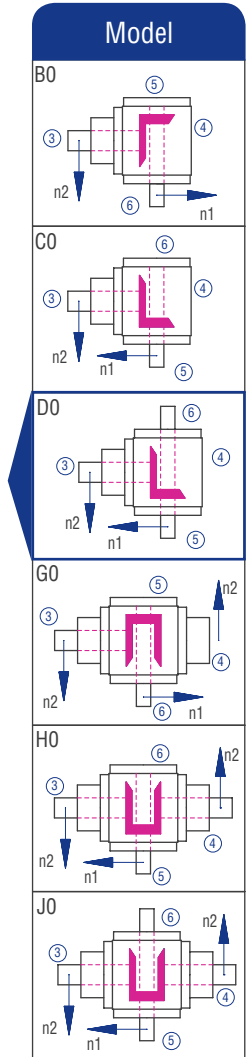
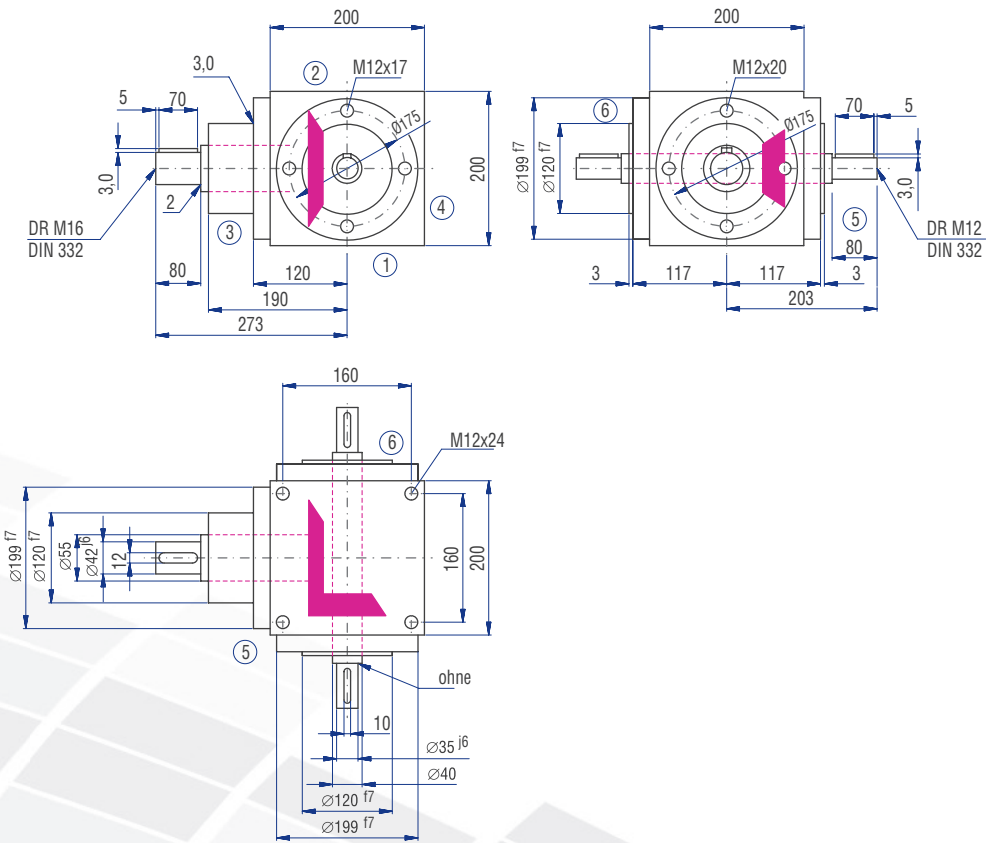

**Permissible radial force  $F_{r2}$  and axial force  $F_{a2}$  on shaft  $N_2$**

$n_2$ [rpm]	1500		1000		500		250		100		50	
$T_{2N}$ [Nm]	$F_r$ [N]	$F_a$ [N]	$F_r$ [N]	$F_a$ [N]	$F_r$ [N]	$F_a$ [N]	$F_r$ [N]	$F_a$ [N]	$F_r$ [N]	$F_a$ [N]	$F_r$ [N]	$F_a$ [N]
< 500	2200	1100	1700	850	3200	1600	3900	1950	5000	2500	6200	3100
> 500	1840	920	1420	710	2670	1335	3250	1625	4170	2085	5170	2585

**Permissible radial force  $F_{r1}$  and axial force  $F_{a1}$  on shaft  $N_1$**

$n_1$ [rpm]	3000		1000		500		250		100		50	
$T_{1N}$ [Nm]	$F_r$ [N]	$F_a$ [N]	$F_r$ [N]	$F_a$ [N]	$F_r$ [N]	$F_a$ [N]	$F_r$ [N]	$F_a$ [N]	$F_r$ [N]	$F_a$ [N]	$F_r$ [N]	$F_a$ [N]
< 350	2670	1335	3580	1790	4170	2085	5420	2710	6670	3335	8330	4165
> 350	2220	1110	2990	1495	3470	1735	4510	2255	5560	2780	6940	3470

**Inertia moments/mass**

Inertia moment  $J_2$  related to the slowly rotating shaft ( $N_2$ )

Model	Inertia moment [kgcm <sup>2</sup> ]	
	1.5:1	2:1
B0	225.000	235.000
C0	225.000	235.000
D0	227.000	239.000
G0	367.000	419.000
H0	367.000	419.000
J0	369.000	423.000

Mass ca. [kg]
48.0
48.0
50.0
58.0
58.0
60.0

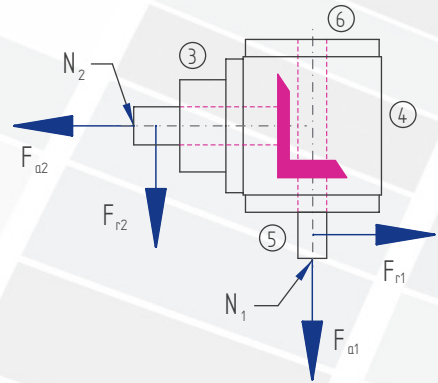

## 6.4.11 Type VS 230 – Type V with step-up ratio

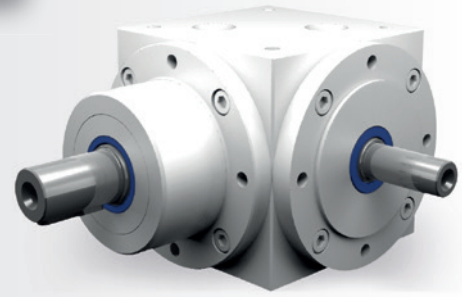

### Characteristics

Characteristic	Standard	Option
Toothing	Bevel gear set, spiral-toothed	See chapter 6.2.1
Gear ratio	1.5:1 to 2:1	
Housing / Flanges	Grey cast iron; steel	
Threaded mounting holes	On all housing surfaces without flange and on all flanges.	See chapter 6.2.3
Shaft	Material 1 C45, shaft ends greased Fit with ISO 6 tolerance with parallel keyway: according to DIN 6885 Sheet 1	See chapter 4.6.2
Hollow shaft	Not deliverable	
Radial shaft seal ring	NBR, form A	See chapter 4.8
Ambient temperature	-10°C to +90°C. The values of the performance tables are valid for +20°C	See chapter 4.9.3
Cumferential backlash	< 30 arcmin	See chapter 6.2.10
Protection class	IP 54	See chapter 4.5
Corrosion protection	Prime coat; layer thickness > 40 µm	See chapter 4.4.1
Bearing life L10h	more than 15,000h	See chapter 4.9.1
Oil change intervals	Not required if the oil temperature is kept < 90°C The lifetime of the bearings can be increased by the factor 1.5 if the oil is changed after the first 500 service hours and then every 5000 service hours.	See chapter 6.2.8
Lubricant	Synthetic lubricants	See chapter 6.2.8

### Performance data

n <sub>1</sub> [rpm]	1.5:1			2:1		
	n <sub>2</sub> [rpm]	P <sub>1N</sub> [kW]	T <sub>2N</sub> [Nm]	n <sub>2</sub> [rpm]	P <sub>1N</sub> [kW]	T <sub>2N</sub> [Nm]
3000	2000	99.20	450	1500	87.63	530
2400	1600	91.35	518	1200	80.02	605
1500	1000	72.20	655	750	59.11	715
1000	667	56.21	765	500	45.19	820
750	500	45.47	825	375	36.79	890
500	333	33.79	920	250	26.73	970
250	167	20.57	1,120	125	16.88	1,225
50	33	4.89	1,330	25	3.66	1,330
P <sub>1Nt</sub> [kW]	34.0			34.0		
T <sub>2max</sub> [Nm]	1400			1400		

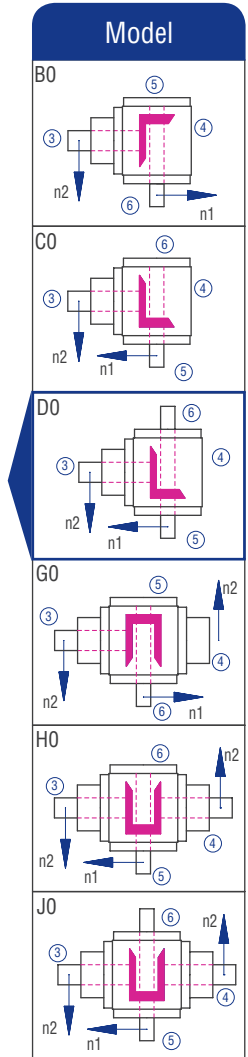
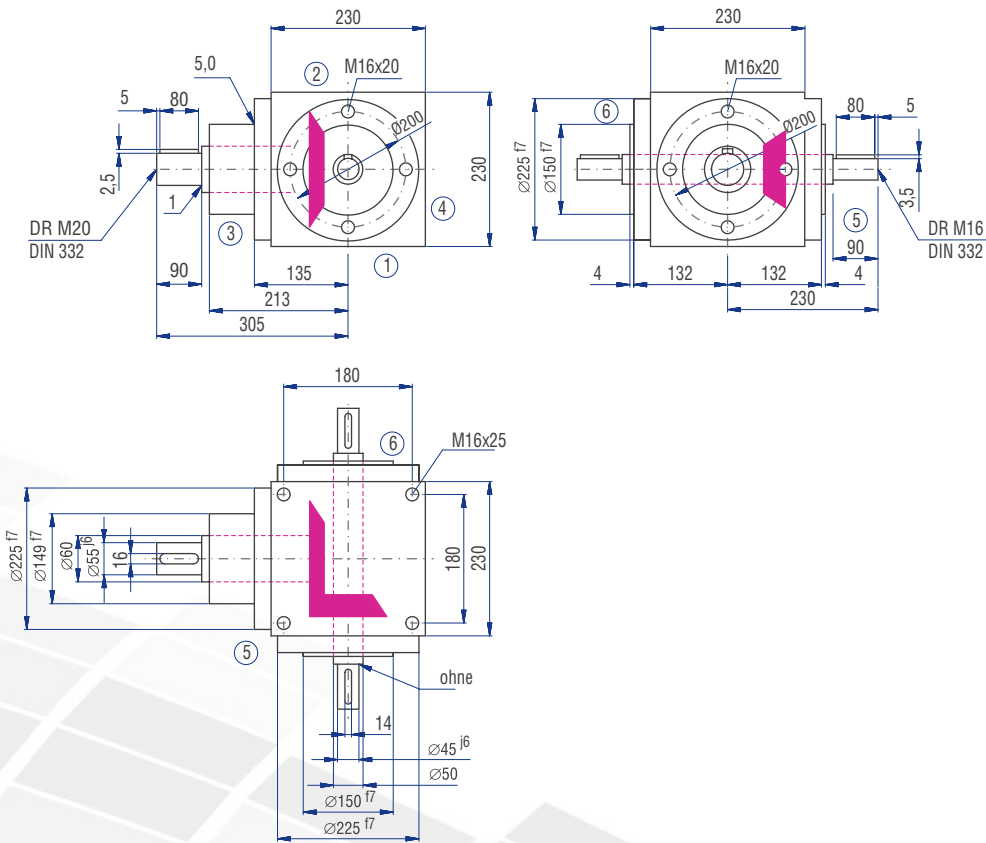

**Permissible radial force  $F_{r2}$  and axial force  $F_{a2}$  on shaft  $N_2$**

$n_2$ [rpm]	1500		1000		500		250		100		50	
$T_{2N}$ [Nm]	$F_r$ [N]	$F_a$ [N]	$F_r$ [N]	$F_a$ [N]	$F_r$ [N]	$F_a$ [N]	$F_r$ [N]	$F_a$ [N]	$F_r$ [N]	$F_a$ [N]	$F_r$ [N]	$F_a$ [N]
< 750	4600	2300	5150	2575	7200	3600	9450	4725	11250	5625	13100	6550
> 750	3832	1916	4290	2145	6000	3000	7876	3938	9376	4688	10918	5459

**Permissible radial force  $F_{r1}$  and axial force  $F_{a1}$  on shaft  $N_1$**

$n_1$ [rpm]	3000		1000		500		250		100		50	
$T_{1N}$ [Nm]	$F_r$ [N]	$F_a$ [N]	$F_r$ [N]	$F_a$ [N]	$F_r$ [N]	$F_a$ [N]	$F_r$ [N]	$F_a$ [N]	$F_r$ [N]	$F_a$ [N]	$F_r$ [N]	$F_a$ [N]
Not specified												

**Inertia moments/mass**

Inertia moment  $J_2$  related to the slowly rotating shaft ( $N_2$ )

Model	Inertia moment [kgcm <sup>2</sup> ]	
	1.5:1	2:1
B0	440.000	528.000
C0	440.000	528.000
D0	442.000	532.000
G0	661.000	749.000
H0	661.000	749.000
J0	663.000	753.000

Mass ca. [kg]
75.0
75.0
77.0
98.0
98.0
100.0

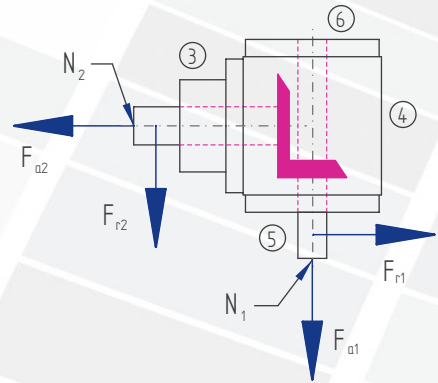

## 6.4.12 Type VS 260 – Type V with step-up ratio

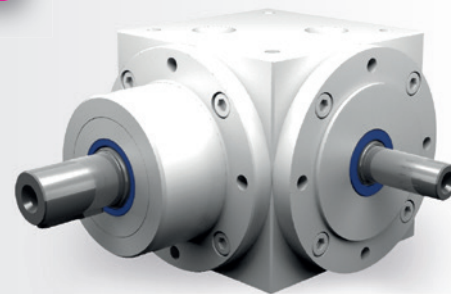

### Characteristics

Characteristic	Standard	Option
Toothing	Bevel gear set, spiral-toothed	See chapter 6.2.1
Gear ratio	1.5:1 to 2:1	
Housing / Flanges	Grey cast iron; steel	
Threaded mounting holes	On all housing surfaces without flange and on all flanges.	See chapter 6.2.3
Shaft	Material 1 C45, shaft ends greased Fit with ISO 6 tolerance with parallel keyway: according to DIN 6885 Sheet 1	See chapter 4.6.2
Hollow shaft	Not deliverable	
Radial shaft seal ring	NBR, form A	See chapter 4.8
Ambient temperature	-10°C to +90°C. The values of the performance tables are valid for +20°C	See chapter 4.9.3
Cumferential backlash	< 30 arcmin	See chapter 6.2.10
Protection class	IP 54	See chapter 4.5
Corrosion protection	Prime coat; layer thickness > 40 µm	See chapter 4.4.1
Bearing life L10h	more than 15,000h	See chapter 4.9.1
Oil change intervals	Not required if the oil temperature is kept < 90°C The lifetime of the bearings can be increased by the factor 1.5 if the oil is changed after the first 500 service hours and then every 5000 service hours.	See chapter 6.2.8
Lubricant	Synthetic lubricants	See chapter 6.2.8

### Performance data

n <sub>1</sub> [rpm]	1.5:1			2:1		
	n <sub>2</sub> [rpm]	P <sub>1N</sub> [kW]	T <sub>2N</sub> [Nm]	n <sub>2</sub> [rpm]	P <sub>1N</sub> [kW]	T <sub>2N</sub> [Nm]
3000	2000	189.58	860	1500	133.92	810
2400	1600	158.72	900	1200	112.43	850
1500	1000	104.71	950	750	78.53	950
1000	667	73.50	1,000	500	57.87	1,050
750	500	55.11	1,000	375	48.36	1,170
500	333	36.70	1,000	250	33.07	1,200
250	167	18.40	1,000	125	16.53	1,200
50	33	3.64	1,000	25	3.31	1,200
P <sub>1Nt</sub> [kW]	42.0			42.0		
T <sub>2max</sub> [Nm]	1000			1200		

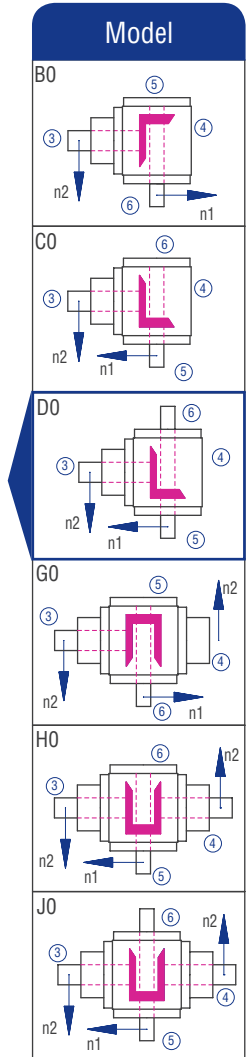
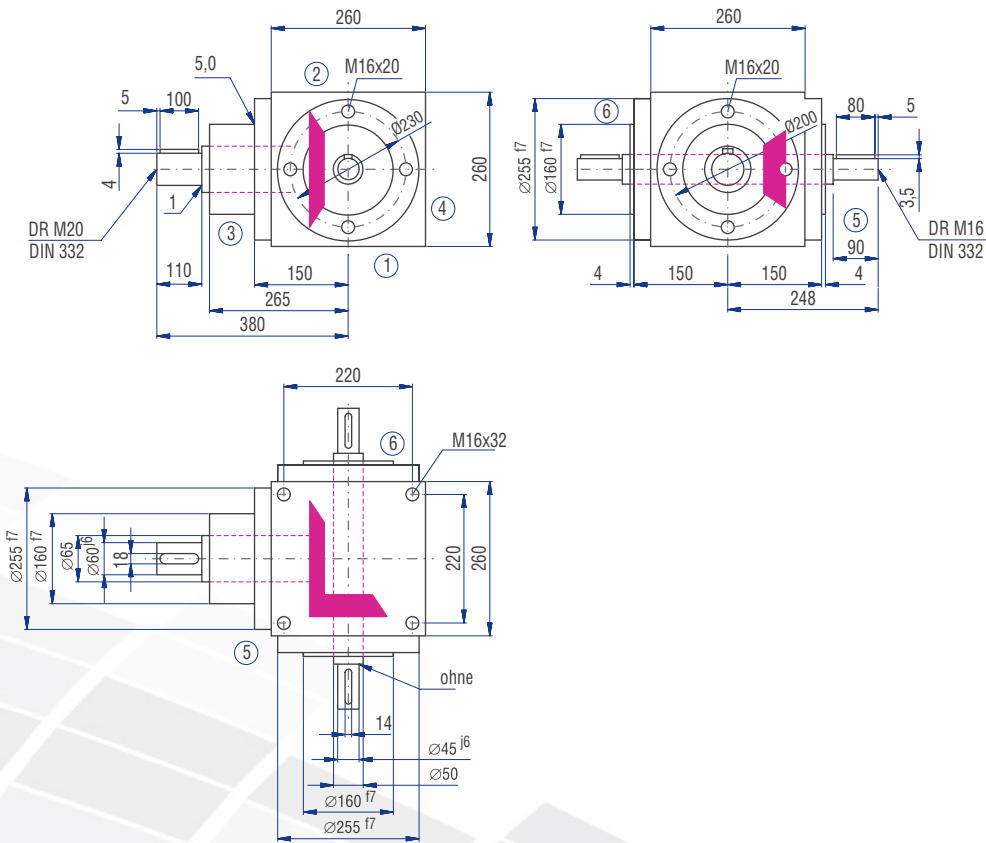

**Permissible radial force  $F_{r2}$  and axial force  $F_{a2}$  on shaft  $N_2$**

$n_2$ [rpm]	1500		1000		500		250		100		50	
$T_{2N}$ [Nm]	$F_r$ [N]	$F_a$ [N]	$F_r$ [N]	$F_a$ [N]	$F_r$ [N]	$F_a$ [N]	$F_r$ [N]	$F_a$ [N]	$F_r$ [N]	$F_a$ [N]	$F_r$ [N]	$F_a$ [N]
< 750	4600	2300	5150	2575	7200	3600	9450	4725	11250	5625	13100	6550
> 750	3832	1916	4290	2145	6000	3000	7876	3938	9376	4688	10918	5459

**Permissible radial force  $F_{r1}$  and axial force  $F_{a1}$  on shaft  $N_1$**

$n_1$ [rpm]	3000		1000		500		250		100		50	
$T_{1N}$ [Nm]	$F_r$ [N]	$F_a$ [N]	$F_r$ [N]	$F_a$ [N]	$F_r$ [N]	$F_a$ [N]	$F_r$ [N]	$F_a$ [N]	$F_r$ [N]	$F_a$ [N]	$F_r$ [N]	$F_a$ [N]
< 650	7010	3505	10900	5450	13000	6500	15000	7500	18000	9000	22000	11000
> 650	5840	2920	9080	4540	10800	5400	12500	6250	15000	7500	18000	9000

**Inertia moments/mass**

Inertia moment  $J_2$  related to the slowly rotating shaft ( $N_2$ )

Model	Inertia moment [kgcm <sup>2</sup> ]	
	1.5:1	2:1
B0	810.000	751.000
C0	810.000	751.000
D0	818.000	763.000
G0	1344.000	1366.000
H0	1344.000	1366.000
J0	1354.000	1378.000

Mass ca. [kg]
83.0
83.0
84.5
107.0
107.0
108.5

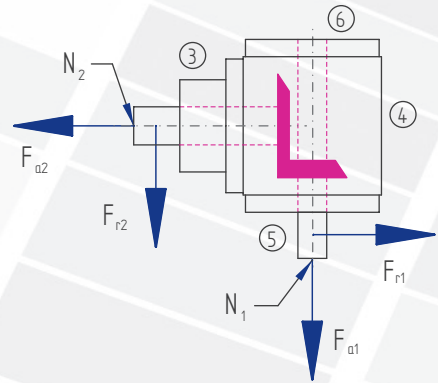

# 6.5 Type VL – Type V with flange for motor mounting

## 6.5.1 Features

- Gear ratios:  $i = 1:1$  to  $6:1$
- Maximum output torque: 2310 Nm
- 8 gearbox sizes with edge lengths of 065 to 260 mm
- Low-backlash construction < 6 angular minutes possible
- Suitable for fitting IEC standard motors
- Drive side with hollow-bored shaft and flange
- Housing made of grey cast iron or steel

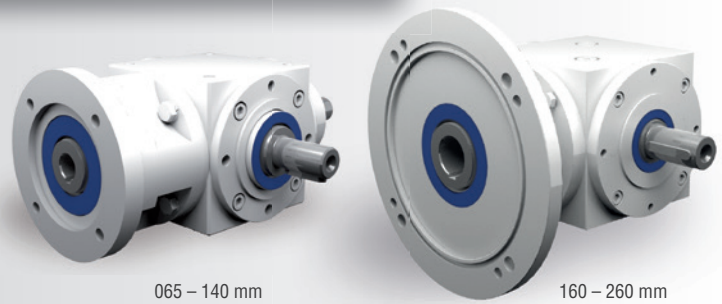

## 6.5.2 Models

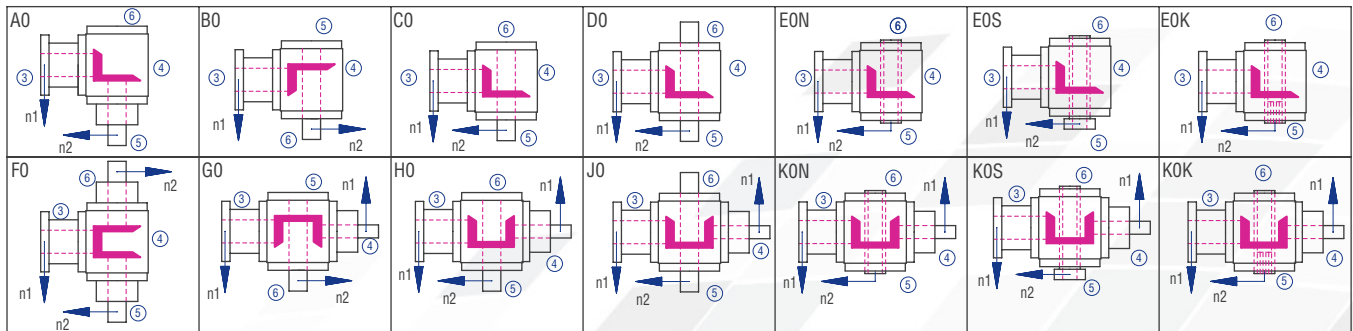

Figure 6.5.2-1; Models

## 6.5.3 Gearbox sides

The example shows the Model C0

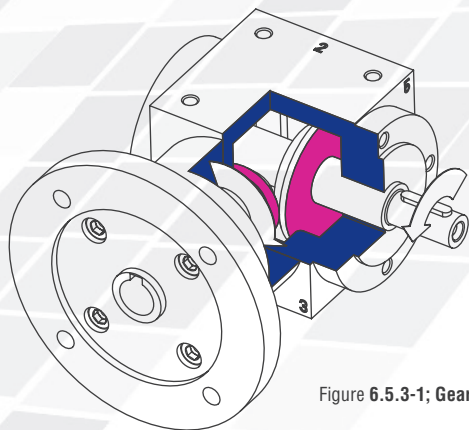

Figure 6.5.3-1; Gearbox sides

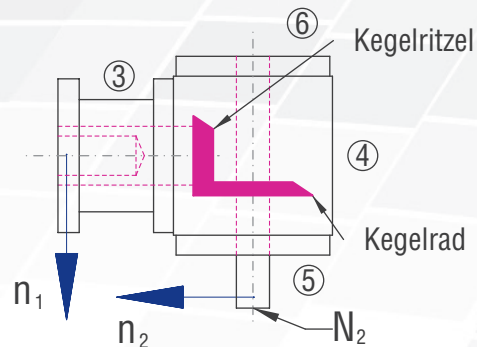

Figure 6.5.3-2; Shaft designations

## 6.5.4 Order code

The order code reflects the customer specifications. Example:

Type	Size	Gear ratio	Model	Fixing side	Installation position	Speed $n_2$	Design
VL	065	1:1	C0-	1.	1-	1500	/0000
Description	Size Table 6.5.5-1	Table 6.5.5-1	Figure 6.5.2-1	Gearbox side on which fixing is made; Table 6.2.3-1; Figure 4.3.1-1; Gearbox sides	Gearbox side directed downwards; Figure 4.3.1-1 Gearbox sides	Slowly rotating shaft; Table 6.5.5-1	Standard
	D120	/14x30					
	Flange diameter	Shaft diameter x length					

Table 6.5.4-1

## 6.5.5 Overview of performance data

P <sub>1</sub> [kW]	n <sub>2</sub> [rpm]	T <sub>2</sub> [Nm]	T <sub>2N</sub> [Nm]	T <sub>2 max</sub> [Nm]	i [-]	IEC motor	Gearbox size	P <sub>1NT</sub> [kW]	
0.12	1340	0.81	11	25	1:1	063A-4	065	1.6	
	893	1.22	11	25	1.5:1	063A-4	065	1.6	
	670	1.62	11	25	2:1	063A-4	065	1.6	
	593	1.84	13	25	1.5:1	063B-6	065	1.6	
	447	2.44	11	23	3:1	063A-4	065	1.6	
	296	3.68	12	23	3:1	063B-6	065	1.6	
0.18	2680	0.61	10	25	1:1	063A-2	065	1.6	
	1787	0.91	10	25	1.5:1	063A-2	065	1.6	
	1340	1.22	10	25	1:1	063B-4	065	1.6	
	893	1.83	10	25	1.5:1	063B-4	065	1.6	
	670	2.44	10	25	2:1	063B-4	065	1.6	
	593	2.75	10	25	1.5:1	071A-6	065	1.6	
	450	3.63	11	23	3:1	063B-4	065	1.6	
	445	3.67	10	25	2:1	071A-6	065	1.6	
	335	4.87	27	70	4:1	063B-4	090	3.8	
	296	5.52	11	23	3:1	071A-6	065	1.6	
	268	6.09	27	60	5:1	063B-4	090	3.8	
	224	7.29	25	50	6:1	063B-4	090	3.8	
0.25	178	9.17	31	60	5:1	071A-6	090	3.8	
	167	9.75	32	70	4:1	080A-8	090	3.8	
	148	11.03	29	50	6:1	071A-6	090	3.8	
	112	14.58	30	50	6:1	080A-8	090	3.8	
	2700	0.84	10	25	1:1	063B-2	065	1.6	
	1800	1.26	10	25	1.5:1	063B-2	065	1.6	
	1350	1.68	10	25	1:1	071A-4	065	1.6	
	890	2.55	10	25	1:1	071B-6	065	1.6	
	675	3.36	10	25	2:1	071A-4	065	1.6	
	540	4.20	23	60	5:1	063B-2	090	3.8	
	450	5.04	27	70	3:1	071A-4	090	3.8	
	450	5.04	11	25	3:1	071A-4	065	1.6	
0.37	337	6.72	27	70	4:1	071A-4	090	3.8	
	296	7.65	31	70	3:1	071B-6	090	3.8	
	270	8.40	27	60	5:1	071A-4	090	3.8	
	225	10.08	25	50	6:1	071A-4	090	3.8	
	178	12.74	31	60	5:1	071B-6	090	3.8	
	148	15.33	29	50	6:1	071B-6	090	3.8	
	134	16.93	32	60	5:1	080B-8	090	3.8	
	112	20.25	30	50	6:1	080B-8	090	3.8	
	2800	1.20	10	25	1:1	071A-2	065	1.6	
	1400	2.40	10	25	2:1	071A-2	065	1.6	
	1350	2.49	10	25	1:1	071B-4	065	1.6	
	933	3.60	10	23	3:1	071A-2	065	1.6	
0.55	900	3.73	29	40	1.5:1	071B-4	090	3.8	
	675	4.97	10	25	2:1	071B-4	065	1.6	
	675	4.97	27	30	2:1	071B-4	090	3.8	
	600	5.59	32	40	1.5:1	080A-6	090	3.8	
	560	5.99	23	60	5:1	071A-2	090	3.8	
	450	7.46	27	70	3:1	071B-4	090	3.8	
	337	9.95	27	70	4:1	071B-4	090	3.8	
	270	12.43	27	60	5:1	071B-4	090	3.8	
	225	14.92	25	50	6:1	071B-4	090	3.8	
	180	18.65	31	60	5:1	080A-6	090	3.8	
	150	22.38	29	50	6:1	080A-6	090	3.8	
	2810	1.78	10	25	1:1	071B-2	065	1.6	
0.75	1873	2.66	10	23	1.5:1	071B-2	065	1.6	
	1405	3.55	10	25	2:1	071B-2	065	1.6	
	936	5.33	10	23	3:1	071B-2	065	1.6	
	936	5.33	23	70	3:1	071B-2	090	3.8	
	906	5.50	29	40	1.5:1	080A-4	090	3.8	
	702	7.10	23	70	4:1	071B-2	090	3.8	
	680	7.34	27	30	2:1	080A-4	090	3.8	
	600	8.32	32	40	1.5:1	080B-6	090	3.8	
	562	8.88	23	60	5:1	071B-2	090	3.8	
	453	11.01	27	70	3:1	080A-4	090	3.8	
	340	14.68	27	70	4:1	080A-4	090	3.8	
	300	16.63	31	70	3:1	080B-6	090	3.8	
1.1	272	18.35	72	140	5:1	080A-4	120	6.2	
	227	21.98	25	50	6:1	080A-4	090	3.8	
	180	27.72	31	60	5:1	080B-6	090	3.8	
	172	28.93	82	155	4:1	090L-8	120	6.2	
	150	33.27	67	120	6:1	080B-6	120	6.2	
	138	36.16	86	140	5:1	090L-8	120	6.2	
	115	43.39	69	120	6:1	090L-8	120	6.2	
	1.5	2820	3.54	27	105	1:1	080B-2	090	3.8
		1880	5.31	25	40	1.5:1	080B-2	090	3.8
		1410	7.08	23	30	2:1	080B-2	090	3.8
		940	10.62	23	70	3:1	080B-2	090	3.8
		920	10.85	78	100	1.5:1	090S-4	120	6.2
705		14.16	23	70	4:1	080B-2	090	3.8	
690		14.46	73	80	2:1	090S-4	120	6.2	
606		16.45	86	100	1.5:1	090L-6	120	6.2	
564		17.69	60	140	5:1	080B-2	120	6.2	
460		21.70	74	155	3:1	090S-4	120	6.2	
345		28.93	74	155	4:1	090S-4	120	6.2	
2.2		303	32.90	82	155	3:1	090L-6	120	6.2
	276	36.16	72	140	5:1	090S-4	120	6.2	
	227	43.87	79	155	4:1	090L-6	120	6.2	
	182	54.83	80	140	5:1	090L-6	120	6.2	
	152	65.66	67	120	6:1	090L-6	120	6.2	
	138	72.32	86	140	5:1	100LB-8	120	6.2	
	1420	9.58	56	80	2:1	090S-2	120	6.2	
	946	14.38	58	155	3:1	090S-2	120	6.2	
	920	14.79	78	100	1.5:1	090L-4	120	6.2	
	710	19.17	60	155	4:1	090S-2	120	6.2	
	690	19.72	73	80	2:1	090L-4	120	6.2	
	613	22.19	78	100	1.5:1	100LA-6	120	6.2	
3.0	568	23.96	60	140	5:1	090S-2	120	6.2	
	460	29.58	74	155	3:1	090L-4	120	6.2	
	345	39.45	74	155	4:1	090L-4	120	6.2	
	306	44.38	82	155	3:1	100LA-6	120	6.2	
	276	49.31	72	140	5:1	090L-4	120	6.2	
	230	59.17	64	120	6:1	090L-4	120	6.2	
	184	73.96	80	140	5:1	100LA-6	120	6.2	
	154	88.37	113	200	6:1	100LA-6	140	10	
	140	97.21	130	250	5:1	112M-8	140	10	
	117	116.31	118	200	6:1	112M-8	140	10	
	1893	10.54	61	100	1.5:1	090L-2	120	6.2	
	1420	14.06	56	80	2:1	090L-2	120	6.2	
940	21.23	78	100	1.5:1	100LA-4	120	6.2		
710	28.11	60	155	4:1	090L-2	120	6.2		
626	31.85	80	100	1.5:1	112M-6	120	6.2		
568	35.14	60	140	5:1	090L-2	120	6.2		
470	42.47	74	155	3:1	100LA-4	120	6.2		
352	56.62	74	155	4:1	100LA-4	120	6.2		
313	63.70	82	155	3:1	112M-6	120	6.2		
188	106.17	124	250	5:1	112M-6	140	10		
157	127.13	165	200	6:1	112M-6	160	15		
141	141.56	240	420	5:1	132SB-8	160	15		
118	169.15	178	200	6:1	132SB-8	160	15		

Table 6.5.5-1

Bavol gearboxes

# 6.5 Type VL – Type V with flange for motor mounting

P <sub>1</sub> [kW]	n <sub>2</sub> [rpm]	T <sub>2</sub> [Nm]	T <sub>2N</sub> [Nm]	T <sub>2 max</sub> [Nm]	i [-]	IEC motor	Gearbox size	P <sub>1NT</sub> [kW]
3	1880	3.62	25	40	1.5:1	080A-2	090	3.8
	1410	4.83	23	30	2:1	080A-2	090	3.8
	1360	5.00	32	105	1:1	080B-4	090	3.8
	940	7.24	23	70	3:1	080A-2	090	3.8
	906	7.50	29	40	1.5:1	080B-4	090	3.8
	705	9.65	23	70	4:1	080A-2	090	3.8
	680	10.01	27	30	2:1	080B-4	090	3.8
	606	11.22	86	100	1.5:1	090S-6	120	6.2
	564	12.06	27	60	5:1	080A-2	090	3.8
	453	15.01	27	70	3:1	080B-4	090	3.8
	340	20.01	27	70	4:1	080B-4	090	3.8
	303	22.43	82	155	3:1	090S-6	120	6.2
	272	25.02	72	140	5:1	080B-4	120	6.2
	227	29.98	64	120	6:1	080B-4	120	6.2
	182	37.39	80	140	5:1	090S-6	120	6.2
	152	44.77	67	113	6:1	090S-6	120	6.2
4	138	49.31	86	140	5:1	100LA-8	120	6.2
	115	59.17	69	118	6:1	100LA-8	120	6.2
	2820	3.54	27	105	1:1	080B-2	090	3.8
	1880	5.31	25	40	1.5:1	080B-2	090	3.8
	1410	7.08	23	30	2:1	080B-2	090	3.8
	940	10.62	23	70	3:1	080B-2	090	3.8
	920	10.85	78	100	1.5:1	090S-4	120	6.2
	705	14.16	23	70	4:1	080B-2	090	3.8
	690	14.46	73	80	2:1	090S-4	120	6.2
	606	16.45	86	100	1.5:1	090L-6	120	6.2
	564	17.69	60	140	5:1	080B-2	120	6.2
	460	21.70	74	155	3:1	090S-4	120	6.2
	345	28.93	74	155	4:1	090S-4	120	6.2
	303	32.90	82	155	3:1	090L-6	120	6.2
	276	36.16	72	140	5:1	090S-4	120	6.2
	227	43.87	79	155	4:1	090L-6	120	6.2
5.5	182	54.83	80	140	5:1	090L-6	120	6.2
	152	65.66	67	120	6:1	090L-6	120	6.2
	138	72.32	86	140	5:1	100LB-8	120	6.2
	1420	9.58	56	80	2:1	090S-2	120	6.2
	946	14.38	58	155	3:1	090S-2	120	6.2
	920	14.79	78	100	1.5:1	090L-4	120	6.2
	710	19.17	60	155	4:1	090S-2	120	6.2
	690	19.72	73	80	2:1	090L-4	120	6.2
	613	22.19	78	100	1.5:1	100LA-6	120	6.2
	568	23.96	60	140	5:1	090S-2	120	6.2
	460	29.58	74	155	3:1	090L-4	120	6.2
	345	39.45	74	155	4:1	090L-4	120	6.2
	306	44.38	82	155	3:1	100LA-6	120	6.2
	276	49.31	72	140	5:1	090L-4	120	6.2
	230	59.17	64	120	6:1	090L-4	120	6.2
	184	73.96	80	140	5:1	100LA-6	120	6.2
154	88.37	113	200	6:1	100LA-6	140	10	
140	97.21	130	250	5:1	112M-8	140	10	
7.5	117	116.31	118	200	6:1	112M-8	140	10
	1893	10.54	61	100	1.5:1	090L-2	120	6.2
	1420	14.06	56	80	2:1	090L-2	120	6.2
	940	21.23	78	100	1.5:1	100LA-4	120	6.2
	710	28.11	60	155	4:1	090L-2	120	6.2
	626	31.85	80	100	1.5:1	112M-6	120	6.2
	568	35.14	60	140	5:1	090L-2	120	6.2
	470	42.47	74	155	3:1	100LA-4	120	6.2
	352	56.62	74	155	4:1	100LA-4	120	6.2
	313	63.70	82	155	3:1	112M-6	120	6.2
	188	106.17	124	250	5:1	112M-6	140	10
	157	127.13	165	200	6:1	112M-6	160	15
	141	141.56	240	420	5:1	132SB-8	160	15
	118	169.15	178	200	6:1	132SB-8	160	15
	240	283.5	485	860	4:1	160MB-6	200	26
	192	354.4	420	860	5:1	160MB-6	200	26
160	425.3	540	1000	6:1	160MB-6	230	34	
144	472.5	1100	1910	5:1	160LB-8	260	42	
144	472.5	770	1200	5:1	160LB-8	230	34	

Table 6.5.5-1

P <sub>1</sub> [kW]	n <sub>2</sub> [rpm]	T <sub>2</sub> [Nm]	T <sub>2N</sub> [Nm]	T <sub>2 max</sub> [Nm]	i [-]	IEC motor	Gearbox size	P <sub>1NT</sub> [kW]	
9	2910	28.06	120	430	1:1	132MA-2	140	10	
	1940	42.09	113	210	1.5:1	132MA-2	140	10	
	1430	57.10	260	660	1:1	132MC-4	160	15	
	1430	57.10	162	430	1:1	132MC-4	140	10	
	970	84.18	190	457	3:1	132MA-2	160	15	
	953	85.65	252	360	1.5:1	132MC-4	160	15	
	953	85.65	155	210	1.5:1	132MC-4	140	10	
	727	112.24	180	422	4:1	132MA-2	160	15	
	715	114.20	138	180	2:1	132MC-4	140	10	
	715	114.20	245	320	2:1	132MC-4	160	15	
	582	140.30	180	420	5:1	132MA-2	160	15	
	476	171.30	230	457	3:1	132MC-4	160	15	
	357	228.40	220	422	4:1	132MC-4	160	15	
	286	285.50	380	860	5:1	132MC-4	200	26	
	238	342.59	490	1000	6:1	132MC-4	230	34	
	11	1940	51.40	330	600	1.5:1	160MA-2	200	26
1465		68.10	450	1090	1:1	160MB-4	200	26	
976		102.20	437	600	1.5:1	160MB-4	200	26	
732		136.20	425	530	2:1	160MB-4	200	26	
640		155.90	505	600	1.5:1	160LA-6	200	26	
582		171.50	300	860	5:1	160MA-2	200	26	
488		204.40	515	910	3:1	160MB-4	200	26	
366		272.50	455	860	4:1	160MB-4	200	26	
293		340.60	380	860	5:1	160MB-4	200	26	
240		415.80	485	860	4:1	160LA-6	200	26	
192		519.80	990	1910	5:1	160LA-6	260	42	
182		546.80	1100	1940	4:1	180L-8	260	42	
146		683.50	1100	1910	5:1	180L-8	260	42	
1953		69.70	330	600	1.5:1	160MB-2	200	26	
1465		92.90	450	1090	1:1	160LA-4	230	34	
1465		92.90	450	1090	1:1	160LA-4	200	26	
15	976	139.30	437	600	1.5:1	160LA-4	200	26	
	732	185.80	425	530	2:1	160LA-4	200	26	
	646	210.40	505	600	1.5:1	180L-6	200	26	
	586	232.20	300	860	5:1	160MB-2	200	26	
	488	278.70	515	910	3:1	160LA-4	200	26	
	366	371.60	455	860	4:1	160LA-4	200	26	
	293	464.50	880	1910	5:1	160LA-4	260	42	
	242	561.18	675	1300	4:1	180L-6	230	34	
	242	561.20	1050	1940	4:1	180L-6	260	42	
	194	701.50	990	1910	5:1	180L-6	260	42	
	146	932.10	1100	1910	5:1	200LB-8	260	42	
	1960	85.60	330	600	1.5:1	160L-2	200	26	
	1470	114.20	450	1090	1:1	180M-4	200	26	
	980	171.30	437	600	1.5:1	180M-4	200	26	
	975	172.10	1050	2310	1:1	200LA-6	230	34	
	975	172.10	1050	2310	1:1	200LA-6	260	42	
735	228.40	425	530	2:1	180M-4	200	26		
650	258.20	1000	1000	1.5:1	200LA-6	260	42		
18.5	588	285.40	300	860	5:1	160L-2	200	26	
	490	342.50	515	910	3:1	180M-4	200	26	
	490	342.53	366	1000	6:1	160L-2	230	34	
	367	456.70	455	860	4:1	180M-4	200	26	
	325	516.43	635	1300	3:1	200LA-6	230	34	
	325	516.40	990	1940	3:1	200LA-6	260	42	
	294	570.90	880	1910	5:1	180M-4	260	42	
	294	570.88	635	1200	5:1	180M-4	230	34	
	243	690.70	1050	1940	4:1	200LA-6	260	42	
	195	860.70	990	1910	5:1	200LA-6	260	42	
	22	1470	135.80	450	1090	1:1	180L-4	230	34
		1470	135.80	450	1090	1:1	180L-4	200	26
		980	203.70	437	600	1.5:1	180L-4	200	26
		735	271.60	425	530	2:1	180L-4	200	26
		650	307.10	1000	1000	1.5:1	200LB-6	260	42
		590	338.29	510	1200	5:1	180M-2	230	34
490		407.30	515	910	3:1	180L-4	200	26	
487		409.80	1050	1200	2:1	200LB-6	260	42	
367		543.90	900	1940	4:1	180L-4	260	42	
367		543.12	600	1300	4:1	180L-4	230	34	
294		678.90	880	1910	5:1	180L-4	260	42	
243		821.40	1050	1940	4:1	200LB-6	260	42	

## 6.5.6 Type VL 065 – Type V with flange for motor mounting

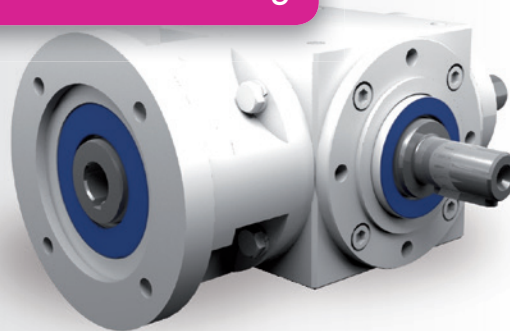

### Characteristics

Characteristic	Standard	Option
<b>Toothing</b>	Bevel gear set, spiral-toothed	See chapter 6.2.1
<b>Gear ratio</b>	1:1 to 3:1	
<b>Housing / Flanges</b>	Grey cast iron	
<b>Threaded mounting hole</b>	On all housing surfaces without flange and on all flanges.	See chapter 6.2.3
<b>Shaft</b>	Material 1 C45, shaft ends greased Fit with ISO 6 tolerance with parallel keyway: according to DIN 6885 Sheet 1	See chapter 4.6.2
<b>Hollow shaft</b>	Material 1 C45, shafts greased Fit with ISO 7 tolerance with parallel keyway: according to DIN 6885 Sheet 1	See chapter 4.6.3
<b>Radial shaft seal ring</b>	NBR, form A	See chapter 4.8
<b>Ambient temperature</b>	-10°C to +90°C. The values of the performance tables are valid for +20°C	See chapter 4.9.3
<b>Circumferential backlash</b>	< 30 arcmin	See chapter 6.2.10
<b>Protection class</b>	IP 54	See chapter 4.5
<b>Corrosion protection</b>	Prime coat; layer thickness > 40 µm	See chapter 4.4.1
<b>Bearing life L10h</b>	more than 15,000h	See chapter 4.9.1
<b>Oil change intervals</b>	Not required if the oil temperature is kept < 90°C The lifetime of the bearings can be increased by the factor 1.5 if the oil is changed after the first 500 service hours and then every 5000 service hours.	See chapter 6.2.8
<b>Lubricants</b>	Synthetic lubricants	See chapter 6.2.8
<b>Flange</b>	Suited for the mounting of IEC motors	
<b>Coupling</b>	Three-piece claw coupling	

## Performance data

n <sub>1</sub> [rpm]	1:1			1.5:1			2:1			3:1			4:1			5:1			6:1			
	n <sub>2</sub> [rpm]	P <sub>1N</sub> [kW]	T <sub>2N</sub> [Nm]	n <sub>2</sub> [rpm]	P <sub>1N</sub> [kW]	T <sub>2N</sub> [Nm]	n <sub>2</sub> [rpm]	P <sub>1N</sub> [kW]	T <sub>2N</sub> [Nm]	n <sub>2</sub> [rpm]	P <sub>1N</sub> [kW]	T <sub>2N</sub> [Nm]	n <sub>2</sub> [rpm]	P <sub>1N</sub> [kW]	T <sub>2N</sub> [Nm]	n <sub>2</sub> [rpm]	P <sub>1N</sub> [kW]	T <sub>2N</sub> [Nm]	n <sub>2</sub> [rpm]	P <sub>1N</sub> [kW]	T <sub>2N</sub> [Nm]	
3000	3000	3.31	10	2000	2.20	10	1500	1.65	10	1000	1.10	10										
2400	2400	2.65	10	1600	1.76	10	1200	1.32	10	800	0.88	10										
1500	1500	1.82	11	1000	1.21	11	750	0.91	11	500	0.61	11										
1000	1000	1.32	12	667	0.88	12	500	0.66	12	333	0.44	12										
750	750	1.07	13	500	0.72	13	375	0.54	13	250	0.33	12										
500	500	0.83	15	333	0.55	15	250	0.41	15	167	0.24	13										
250	250	0.47	17	167	0.31	17	125	0.23	17	83	0.12	13										
50	50	0.10	18	33	0.07	18	25	0.05	18	17	0.03	14										
P <sub>1Nt</sub> [kW]		1.6			1.6			1.6			1.6											
T <sub>2max</sub> [Nm]		25			25			25			23											

## Permissible radial force F<sub>r2</sub> and axial force F<sub>a2</sub> on shaft N<sub>2</sub>

n <sub>2</sub> [rpm]	3000		1000		500		250		100		50	
T <sub>2N</sub> [Nm]	F <sub>r</sub> [N]	F <sub>a</sub> [N]	F <sub>r</sub> [N]	F <sub>a</sub> [N]	F <sub>r</sub> [N]	F <sub>a</sub> [N]	F <sub>r</sub> [N]	F <sub>a</sub> [N]	F <sub>r</sub> [N]	F <sub>a</sub> [N]	F <sub>r</sub> [N]	F <sub>a</sub> [N]
< 12	300	150	400	200	500	250	650	325	750	375	900	450
> 12	250	125	330	165	420	210	540	270	630	315	750	375

## Inertia moments/mass

Inertia moment J<sub>1</sub> related to the fast-rotating shaft (N<sub>1</sub>)

Model	Inertia moment [kgcm <sup>2</sup> ]						
	1:1	1.5:1	2:1	3:1	4:1	5:1	6:1
AO	0.62060	0.48590	0.43630	0.37670			
BO	0.65490	0.55640	0.48540	0.37320			
CO	0.65490	0.55640	0.48540	0.37320			
DO	0.66480	0.56080	0.48790	0.37430			
EON	0.70720	0.60870	0.53770	0.42550			
EOS	0.83300	0.73450	0.66350	0.55130			
FO	0.81500	0.57230	0.48490	0.39830			
GO	0.84930	0.71060	0.62070	0.45520			
HO	0.84930	0.71060	0.62070	0.45520			
JO	0.85920	0.71500	0.62320	0.45630			
KON	0.90160	0.76290	0.67300	0.50750			
KOS	1.02740	0.88870	0.79880	0.63330			

Mass [kg]
3.3
3.2
3.2
3.3
3.1
3.1
3.7
3.6
3.6
3.7
3.5
3.5

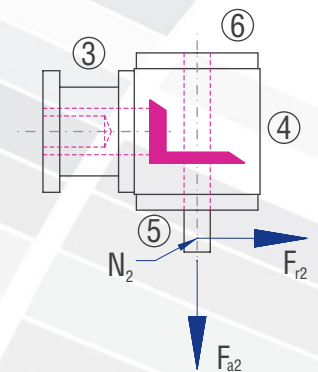

# 6.5.6 Type VL 065 – Type V with flange for motor mounting

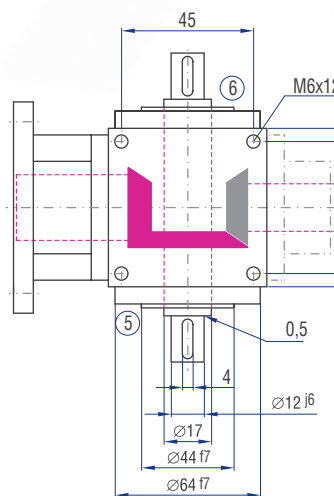
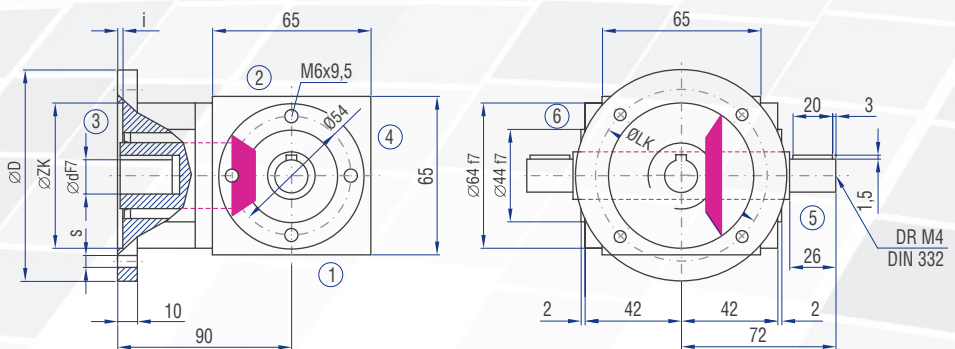
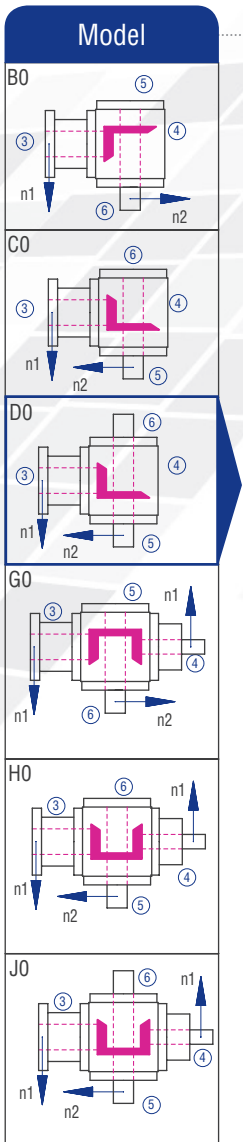
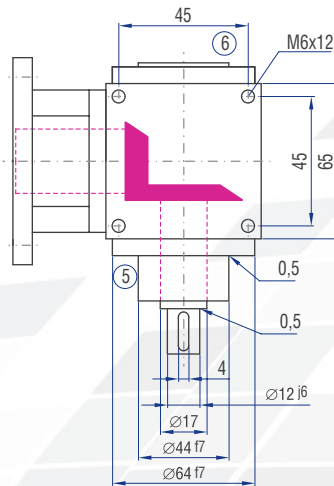
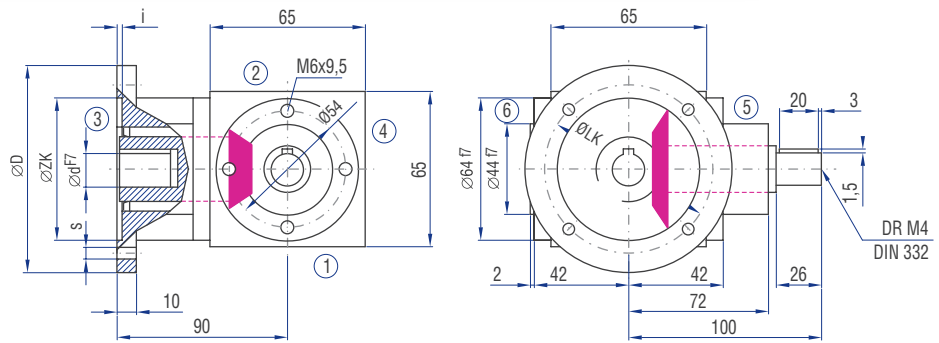
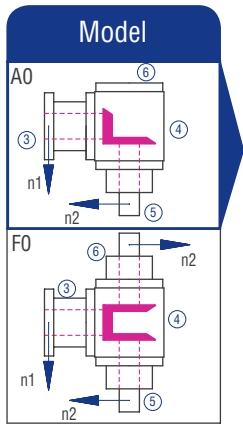

Implementation VV  
on demand

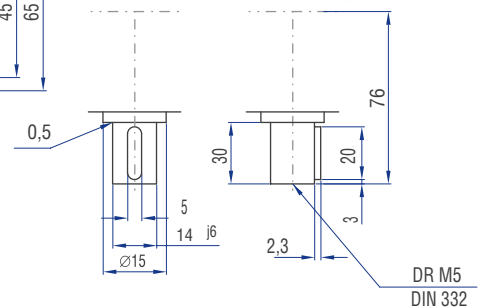

IEC motor	Model	Shaft (d x l)	D [mm]	LK [mm]	ZK [mm]	s [mm]	i [mm]
63	B14	11x23	120	100	80	7	3
	B5	11x23	140	115	95	9	3
71	B14	14x30	105	85	70	7	3
	B14	14x30	140	115	95	9	3

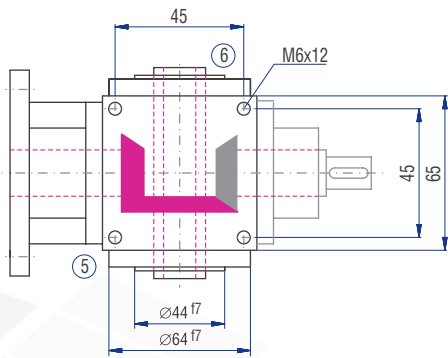
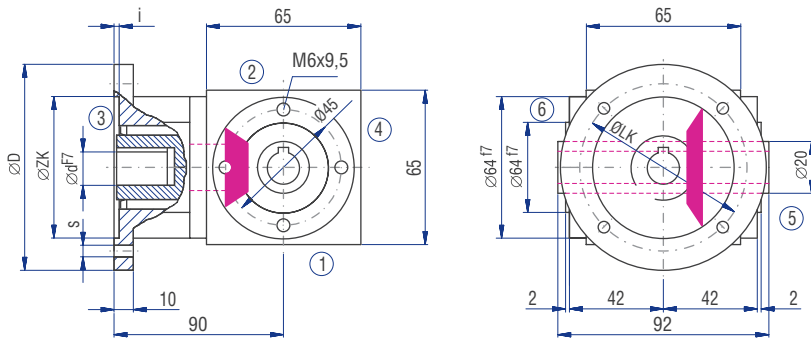

### Implementation

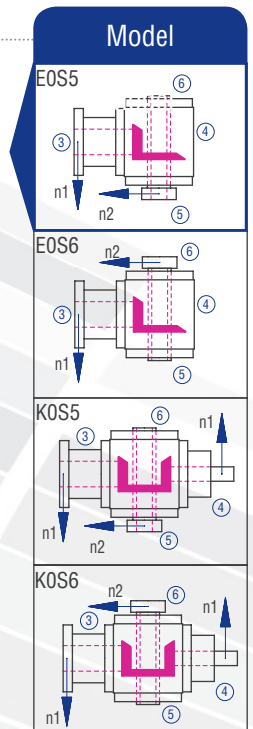
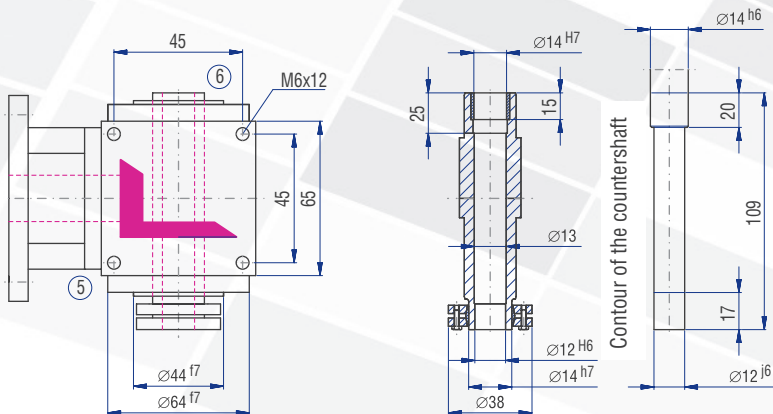
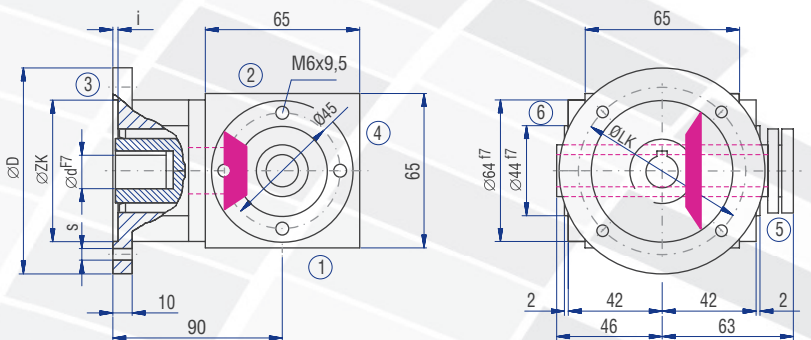
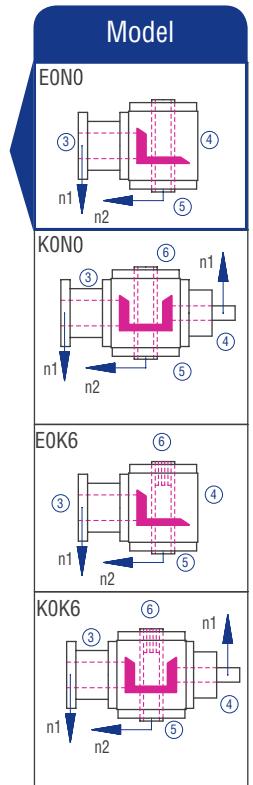
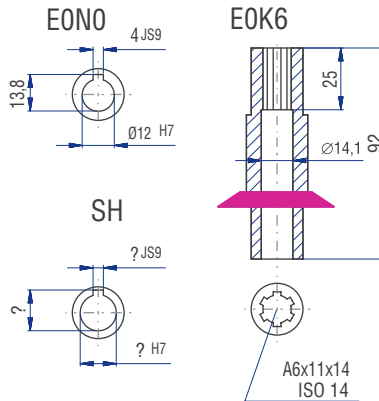

The dimensions of the Models not shown can be figured by mirroring available dimensions.  
The shaft dimensions on side 4 follow from the dimensions of type A0.

## 6.5.7 Type VL 090 – Type V with flange for motor mounting

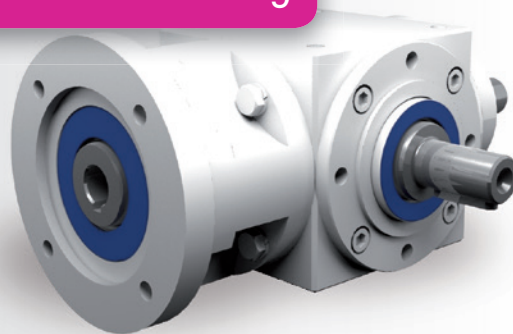

### Characteristics

Characteristic	Standard	Option
<b>Toothing</b>	Bevel gear set, spiral-toothed	See chapter 6.2.1
<b>Gear ratio</b>	1:1 to 6:1	
<b>Housing / Flanges</b>	Grey cast iron	
<b>Threaded mounting hole</b>	On all housing surfaces without flange and on all flanges.	See chapter 6.2.3
<b>Shaft</b>	Material 1 C45, shaft ends greased Fit with ISO 6 tolerance with parallel keyway: according to DIN 6885 Sheet 1	See chapter 4.6.2
<b>Hollow shaft</b>	Material 1 C45, shafts greased Fit with ISO 7 tolerance with parallel keyway: according to DIN 6885 Sheet 1	See chapter 4.6.3
<b>Radial shaft seal ring</b>	NBR, form A	See chapter 4.8
<b>Ambient temperature</b>	-10°C to +90°C. The values of the performance tables are valid for +20°C	See chapter 4.9.3
<b>Circumferential backlash</b>	< 30 arcmin	See chapter 6.2.10
<b>Protection class</b>	IP 54	See chapter 4.5
<b>Corrosion protection</b>	Prime coat; layer thickness > 40 µm	See chapter 4.4.1
<b>Bearing life L10h</b>	more than 15,000h	See chapter 4.9.1
<b>Oil change intervals</b>	Not required if the oil temperature is kept < 90°C The lifetime of the bearings can be increased by the factor 1.5 if the oil is changed after the first 500 service hours and then every 5000 service hours.	See chapter 6.2.8
<b>Lubricants</b>	Synthetic lubricants	See chapter 6.2.8
<b>Flange</b>	Suited for the mounting of IEC motors	
<b>Coupling</b>	Three-piece claw coupling	

## Performance data

n <sub>1</sub> [rpm]	1:1			1.5:1			2:1			3:1			4:1			5:1			6:1			
	n <sub>2</sub> [rpm]	P <sub>1N</sub> [kW]	T <sub>2N</sub> [Nm]	n <sub>2</sub> [rpm]	P <sub>1N</sub> [kW]	T <sub>2N</sub> [Nm]	n <sub>2</sub> [rpm]	P <sub>1N</sub> [kW]	T <sub>2N</sub> [Nm]	n <sub>2</sub> [rpm]	P <sub>1N</sub> [kW]	T <sub>2N</sub> [Nm]	n <sub>2</sub> [rpm]	P <sub>1N</sub> [kW]	T <sub>2N</sub> [Nm]	n <sub>2</sub> [rpm]	P <sub>1N</sub> [kW]	T <sub>2N</sub> [Nm]	n <sub>2</sub> [rpm]	P <sub>1N</sub> [kW]	T <sub>2N</sub> [Nm]	
3000	3000	8.93	27	2000	5.51	25	1500	3.80	23	1000	2.54	23	750	1.90	23	600	1.52	23	500	1.25	23	
2400	2400	7.41	28	1600	4.59	26	1200	3.17	24	800	2.12	24	600	1.65	25	480	1.32	25	400	1.09	25	
1500	1500	5.29	32	1000	3.20	29	750	2.23	27	500	1.49	27	375	1.12	27	300	0.89	27	250	0.74	27	
1000	1000	3.75	34	667	2.35	32	500	1.71	31	333	1.14	31	250	0.85	31	200	0.68	31	167	0.53	29	
750	750	3.06	37	500	1.93	35	375	1.32	32	250	0.88	32	188	0.66	32	150	0.53	32	125	0.40	29	
500	500	2.20	40	333	1.36	37	250	0.94	34	167	0.63	34	125	0.47	34	100	0.37	34	83	0.27	29	
250	250	1.21	44	167	0.74	40	125	0.50	36	83	0.33	36	63	0.25	36	50	0.20	36	42	0.14	30	
50	50	0.28	50	33	0.16	45	25	0.10	37	17	0.07	37	13	0.05	37	10	0.04	37	8	0.03	33	
P <sub>1Nt</sub> [kW]		3.8			3.8			3.8			3.8			3.8			3.8					
T <sub>2max</sub> [Nm]		105			80			80			70			70			60			50		

## Permissible radial force F<sub>r2</sub> and axial force F<sub>a2</sub> on shaft N<sub>2</sub>

n <sub>2</sub> [rpm]	3000		1000		500		250		100		50	
T <sub>2N</sub> [Nm]	F <sub>r</sub> [N]	F <sub>a</sub> [N]	F <sub>r</sub> [N]	F <sub>a</sub> [N]	F <sub>r</sub> [N]	F <sub>a</sub> [N]	F <sub>r</sub> [N]	F <sub>a</sub> [N]	F <sub>r</sub> [N]	F <sub>a</sub> [N]	F <sub>r</sub> [N]	F <sub>a</sub> [N]
< 30	500	250	660	330	800	400	950	475	1250	625	1500	750
> 30	420	210	550	275	670	335	790	395	1040	520	1250	625

## Inertia moments/mass

Inertia moment J<sub>1</sub> related to the fast-rotating shaft (N<sub>1</sub>)

Model	Inertia moment [kgcm <sup>2</sup> ]						
	1:1	1.5:1	2:1	3:1	4:1	5:1	6:1
A0	2.88400	1.82740	1.48200	1.22120	1.15050	1.09920	1.09330
B0	3.67930	2.52850	1.70350	1.37930	1.24810	1.16770	1.13730
C0	3.67930	2.52850	1.70350	1.37930	1.24810	1.16770	1.13730
D0	3.70770	2.54110	1.71060	1.38240	1.24990	1.16890	1.13810
E0N	3.57570	2.48240	1.67760	1.36780	1.24160	1.16360	1.13440
E0S	4.24630	2.78050	1.84520	1.44230	1.28350	1.19040	1.15310
F0	4.16350	2.39600	1.80190	1.36330	1.23040	1.15040	1.12890
G0	4.95880	3.44200	2.52730	2.12550	1.53120	1.44130	1.40800
H0	4.95880	3.44200	2.52730	2.12550	1.53120	1.44130	1.40800
J0	4.98720	3.45460	2.53440	2.12860	1.53300	1.44250	1.40880
K0N	4.85520	3.39590	2.50140	2.11400	1.52470	1.43720	1.40510
K0S	5.52580	3.69400	2.66900	2.18850	1.56660	1.46110	1.42380

Mass [kg]
6.7
7.0
7.0
7.1
6.6
6.8
7.9
8.5
8.5
8.6
8.1
8.3

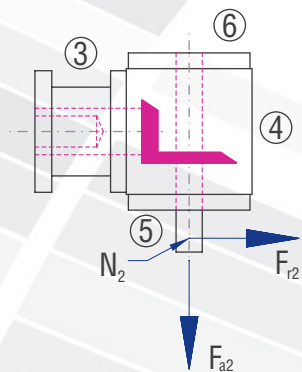

# 6.5.7 Type VL 090 – Type V with flange for motor mounting

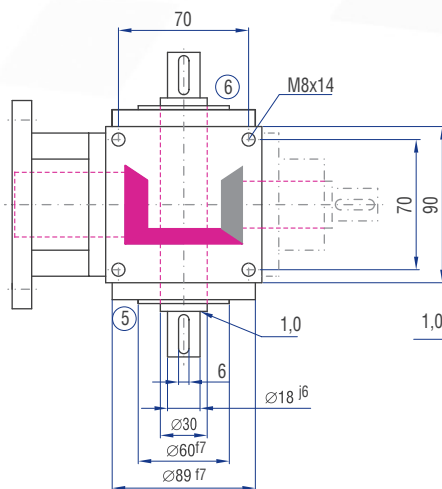
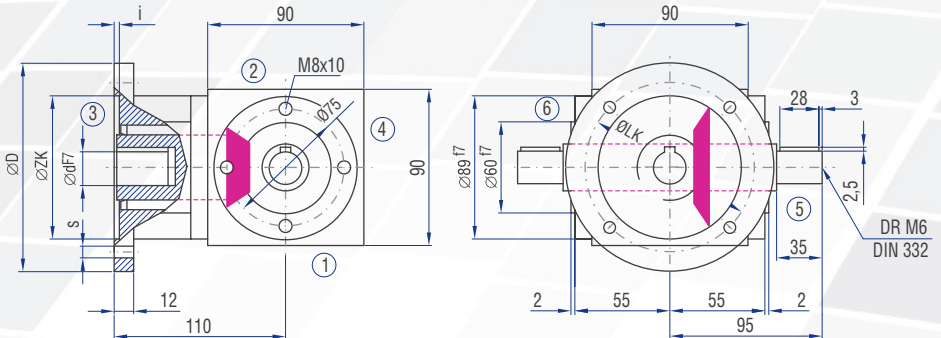
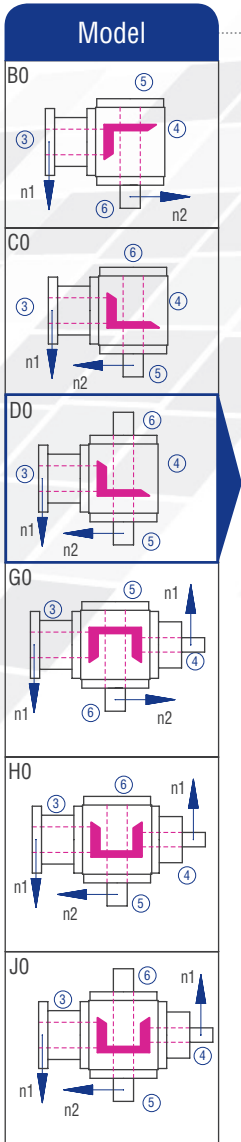
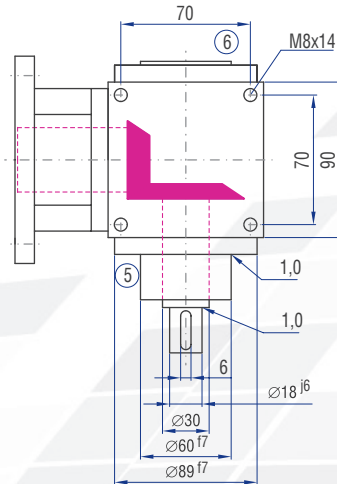
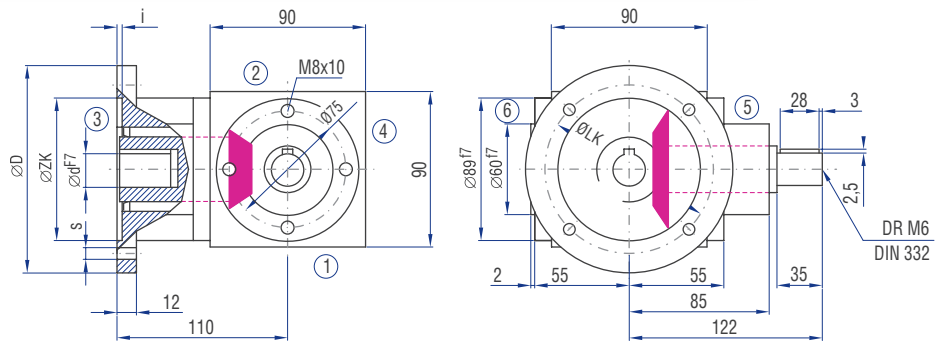
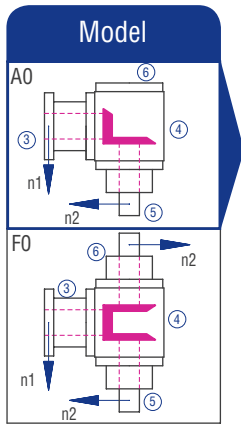

## Implementation VV

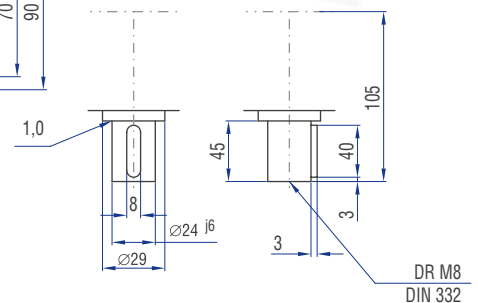

IEC motor	Model	Shaft (dxl)	D [mm]	LK [mm]	ZK [mm]	s [mm]	i [mm]
63	B14	11x23	120	100	80	7	3
	B5	11x23	140	115	95	9	3
71	B14	14x30	140	115	95	9	3
	B5	14x30	160	130	110	9	4
80	B14	19x40	120	100	80	7	3
	B14	19x40	160	130	110	9	4

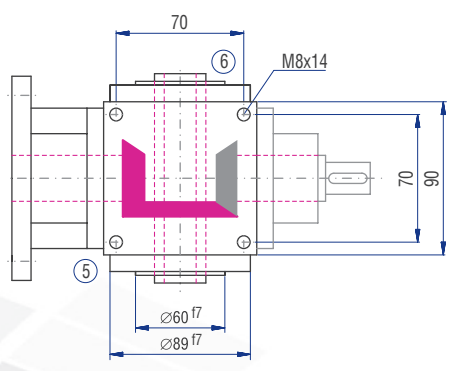
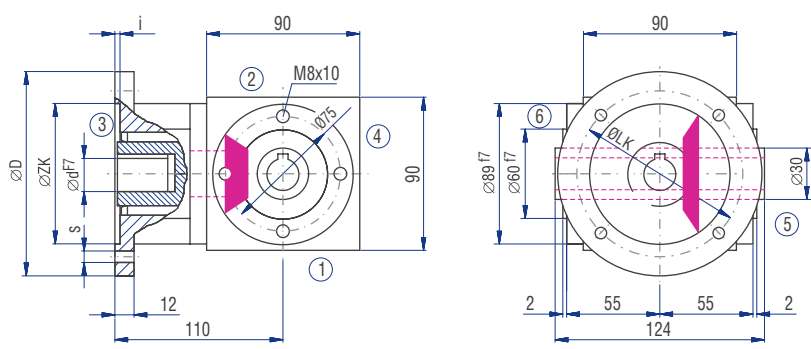

### Implementation

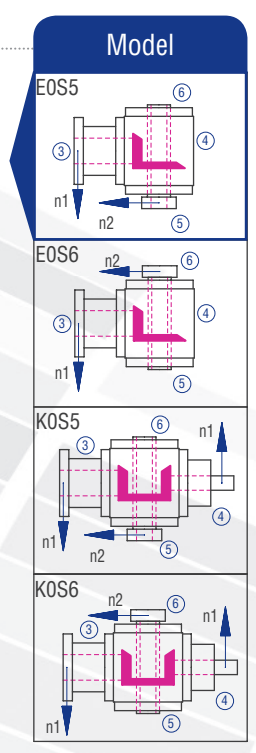
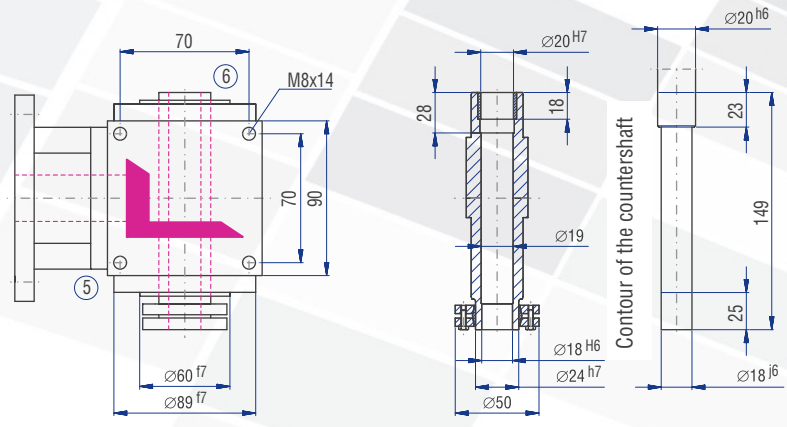
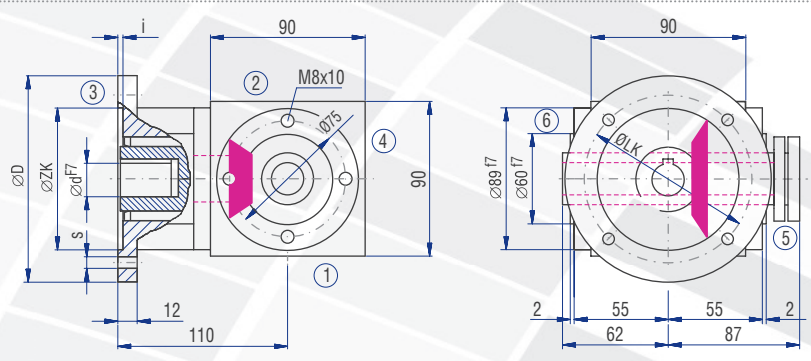
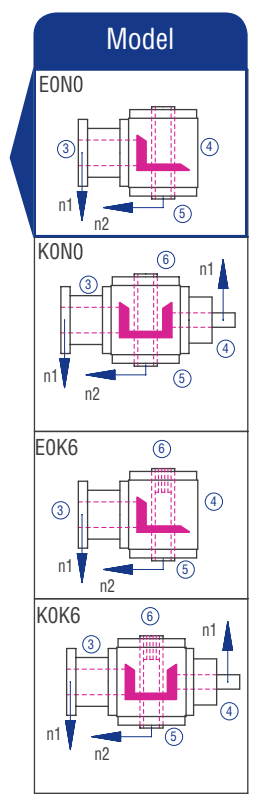
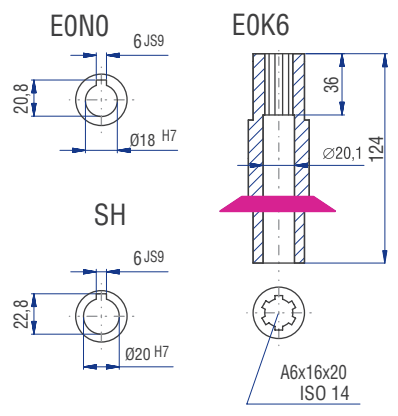

The dimensions of the Models not shown can be figured by mirroring available dimensions.  
The shaft dimensions on side 4 follow from the dimensions of type A0.

## 6.5.8 Type VL 120 – Type V with flange for motor mounting

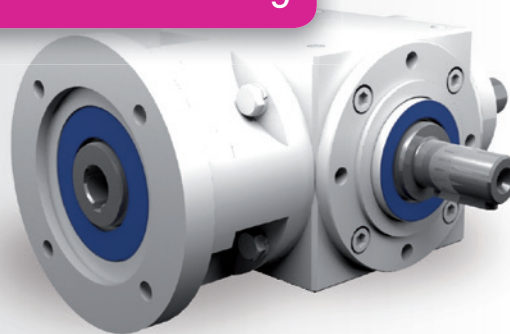

### Characteristics

Characteristic	Standard	Option
<b>Toothing</b>	Bevel gear set, spiral-toothed	See chapter 6.2.1
<b>Gear ratio</b>	1:1 to 6:1	
<b>Housing / Flanges</b>	Grey cast iron	
<b>Threaded mounting hole</b>	On all housing surfaces without flange and on all flanges.	See chapter 6.2.3
<b>Shaft</b>	Material 1 C45, shaft ends greased Fit with ISO 6 tolerance with parallel keyway: according to DIN 6885 Sheet 1	See chapter 4.6.2
<b>Hollow shaft</b>	Material 1 C45, shafts greased Fit with ISO 7 tolerance with parallel keyway: according to DIN 6885 Sheet 1	See chapter 4.6.3
<b>Radial shaft seal ring</b>	NBR, form A	See chapter 4.8
<b>Ambient temperature</b>	-10°C to +90°C. The values of the performance tables are valid for +20°C	See chapter 4.9.3
<b>Circumferential backlash</b>	< 30 arcmin	See chapter 6.2.10
<b>Protection class</b>	IP 54	See chapter 4.5
<b>Corrosion protection</b>	Prime coat; layer thickness > 40 µm	See chapter 4.4.1
<b>Bearing life L10h</b>	more than 15,000h	See chapter 4.9.1
<b>Oil change intervals</b>	Not required if the oil temperature is kept < 90°C The lifetime of the bearings can be increased by the factor 1.5 if the oil is changed after the first 500 service hours and then every 5000 service hours.	See chapter 6.2.8
<b>Lubricants</b>	Synthetic lubricants	See chapter 6.2.8
<b>Flange</b>	Suited for the mounting of IEC motors	
<b>Coupling</b>	Three-piece claw coupling	

## Performance data

n <sub>1</sub> [rpm]	1:1			1.5:1			2:1			3:1			4:1			5:1			6:1									
	n <sub>2</sub> [rpm]	P <sub>1N</sub> [kW]	T <sub>2N</sub> [Nm]	n <sub>2</sub> [rpm]	P <sub>1N</sub> [kW]	T <sub>2N</sub> [Nm]	n <sub>2</sub> [rpm]	P <sub>1N</sub> [kW]	T <sub>2N</sub> [Nm]	n <sub>2</sub> [rpm]	P <sub>1N</sub> [kW]	T <sub>2N</sub> [Nm]	n <sub>2</sub> [rpm]	P <sub>1N</sub> [kW]	T <sub>2N</sub> [Nm]	n <sub>2</sub> [rpm]	P <sub>1N</sub> [kW]	T <sub>2N</sub> [Nm]	n <sub>2</sub> [rpm]	P <sub>1N</sub> [kW]	T <sub>2N</sub> [Nm]							
3000	3000	21.82	66	2000	13.45	61	1500	9.26	56	1000	6.39	58	750	4.96	60	600	3.97	60	500	2.95	54							
2400	2400	18.52	70	1600	11.46	65	1200	8.07	61	800	5.56	63	600	4.43	67	480	3.44	65	400	2.53	57							
1500	1500	13.56	82	1000	8.60	78	750	6.03	73	500	4.08	74	375	3.06	74	300	2.38	72	250	1.75	64							
1000	1000	10.14	92	667	6.32	86	500	4.40	80	333	3.01	82	250	2.18	79	200	1.76	80	167	1.22	66							
750	750	8.51	103	500	5.18	94	375	3.30	80	250	2.40	87	188	1.69	82	150	1.42	86	125	0.94	68							
500	500	6.34	115	333	3.70	100	250	2.20	80	167	1.66	90	125	1.16	84	100	0.98	89	83	0.63	69							
250	250	3.39	123	167	1.84	100	125	1.10	80	83	0.87	95	63	0.60	87	50	0.51	92	42	0.33	71							
50	50	0.72	130	33	0.37	100	25	0.22	80	17	0.21	110	13	0.12	90	10	0.10	95	8	0.06	66							
<b>P<sub>1Nt</sub> [kW]</b>		6.2			6.2			6.2			6.2			6.2			6.2			6.2								
<b>T<sub>2max</sub> [Nm]</b>		220			169			80			155			155			140			120								

## Permissible radial force F<sub>r2</sub> and axial force F<sub>a2</sub> on shaft N<sub>2</sub>

n <sub>2</sub> [rpm]	3000		1000		500		250		100		50	
T <sub>2N</sub> [Nm]	F <sub>r</sub> [N]	F <sub>a</sub> [N]	F <sub>r</sub> [N]	F <sub>a</sub> [N]	F <sub>r</sub> [N]	F <sub>a</sub> [N]	F <sub>r</sub> [N]	F <sub>a</sub> [N]	F <sub>r</sub> [N]	F <sub>a</sub> [N]	F <sub>r</sub> [N]	F <sub>a</sub> [N]
< 80	750	375	1000	500	1250	625	1500	750	1900	950	2200	1100
> 80	630	315	830	415	1040	520	1250	625	1580	790	1830	915

## Inertia moments/mass

Inertia moment J<sub>1</sub> related to the fast-rotating shaft (N<sub>1</sub>)

Model	Inertia moment [kgcm <sup>2</sup> ]							Mass [kg]
	1:1	1.5:1	2:1	3:1	4:1	5:1	6:1	
A0	12.5824	6.93340	5.40030	4.79750	4.46280	4.29660	4.22670	15.6
B0	17.3870	9.53660	6.72850	5.49390	4.91930	4.60430	4.44830	15.3
C0	17.3870	9.53660	6.72850	5.49390	4.91930	4.60430	4.44830	15.3
D0	17.6844	9.66870	6.80280	5.52690	4.93790	4.61620	4.45660	15.5
E0N	17.2787	9.48840	6.70140	5.48190	4.91250	4.60000	4.44530	15.0
E0S	19.0660	10.2828	7.14820	5.68040	5.02420	4.67150	4.49500	15.3
F0	17.8312	9.26620	6.71250	5.38070	4.79080	4.50650	4.37250	18.0
G0	22.6358	12.0447	9.06280	7.22660	5.80760	5.14590	4.97910	17.7
H0	22.6358	12.0447	9.06280	7.22660	5.80760	5.14590	4.97910	17.7
J0	22.9332	12.1768	9.13710	7.25960	5.82620	5.15780	4.98740	17.9
K0N	22.5275	11.9965	9.03570	7.21460	5.80080	5.14160	4.97610	17.4
K0S	24.3148	12.7909	9.48250	7.41310	5.91250	5.21310	5.02580	17.7

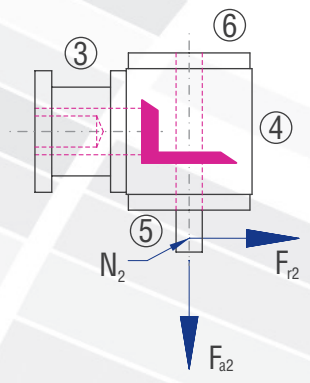

# 6.5.8 Type VL 120 – Type V with flange for motor mounting

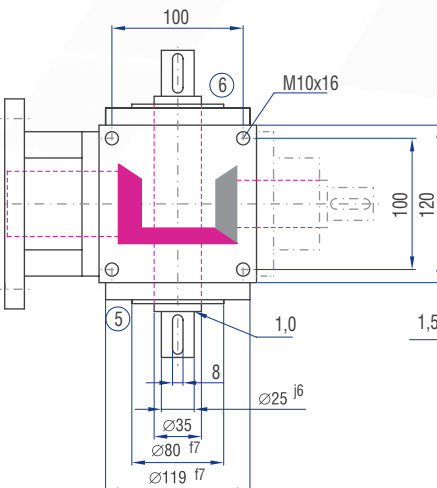
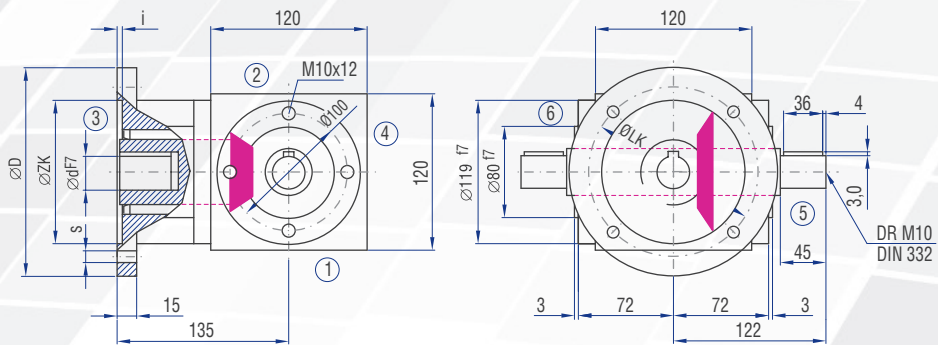
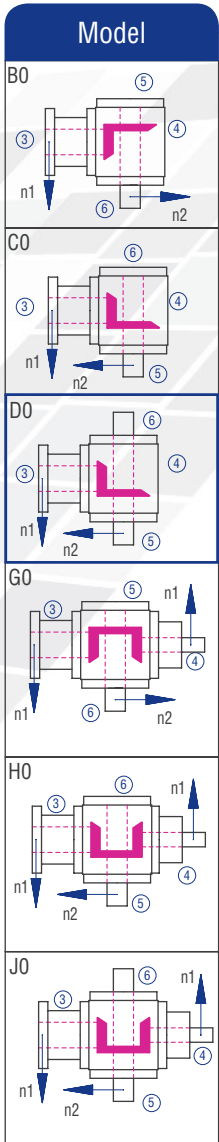
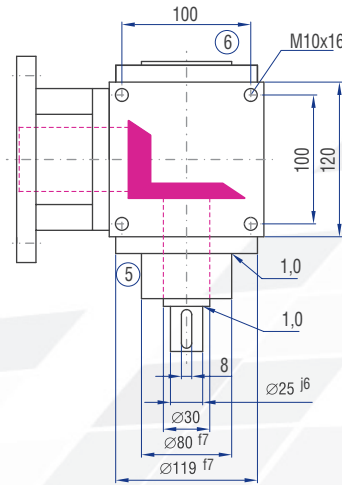
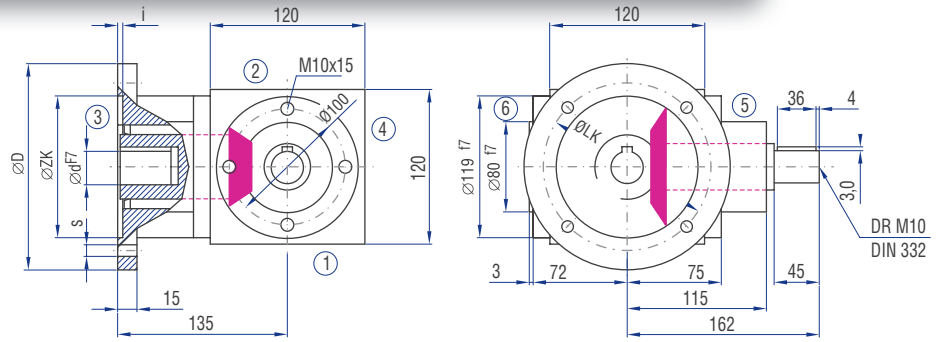
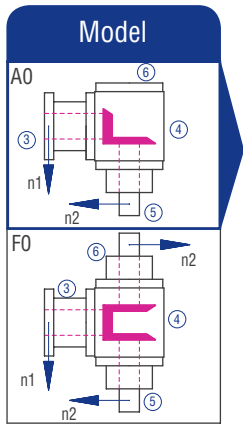

## Implementation VV

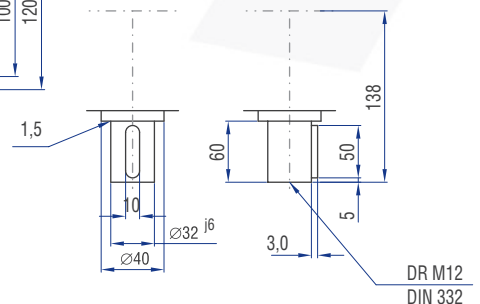

IEC motor	Model	Shaft (dxl)	D [mm]	LK [mm]	ZK [mm]	s [mm]	i [mm]
71	B14	14x30	140	115	95	9	3
	B5	19x40	160	130	110	9	4
80	B14	19x40	200	165	130	11	4
	B5	24x50	200	165	130	11	4
90	B14	24x50	160	130	110	9	4
	B5	24x50	200	165	130	11	4
100	B14	28x60	200	165	130	11	4
	B5	28x60	250	215	180	14	5
112	B14	28x60	200	165	130	11	4
	B5	28x60	250	215	180	14	5

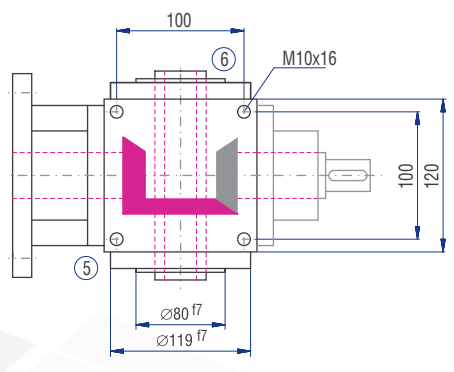
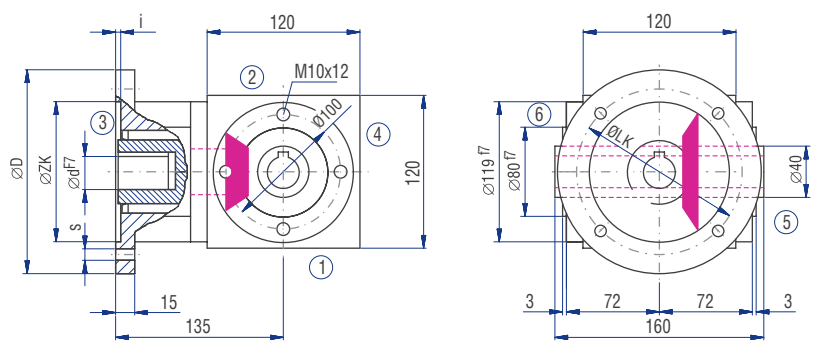

### Implementation

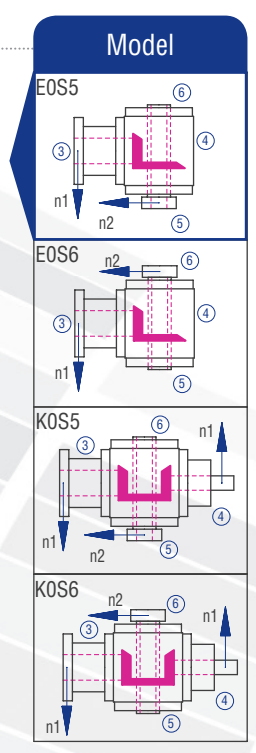
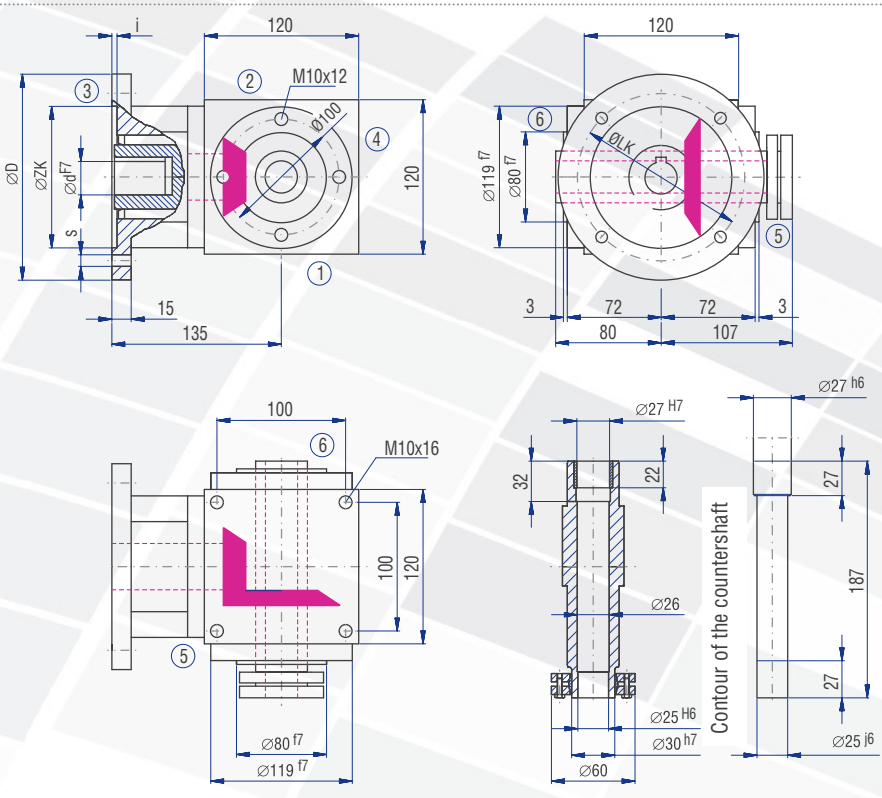
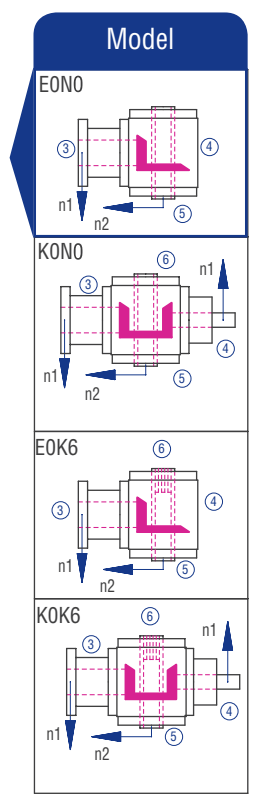
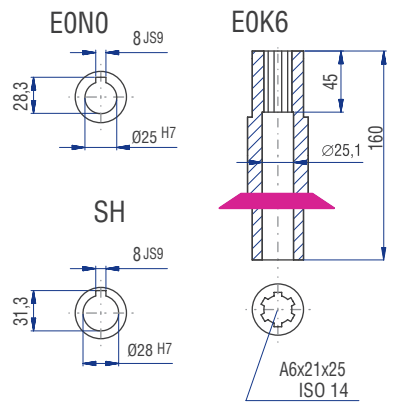

The dimensions of the Models not shown can be figured by mirroring available dimensions.  
The shaft dimensions on side 4 follow from the dimensions of type A0.

## 6.5.9 Type VL 140 – Type V with flange for motor mounting

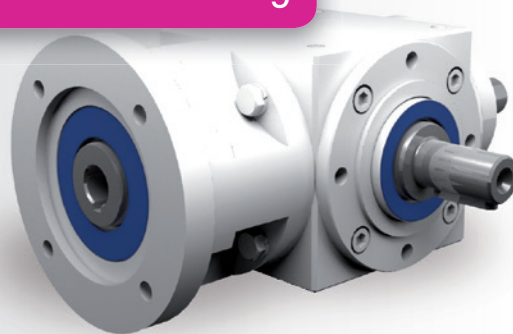

### Characteristics

Characteristic	Standard	Option
<b>Toothing</b>	Bevel gear set, spiral-toothed	See chapter 6.2.1
<b>Gear ratio</b>	1:1 to 6:1	
<b>Housing / Flanges</b>	Grey cast iron	
<b>Threaded mounting hole</b>	On all housing surfaces without flange and on all flanges.	See chapter 6.2.3
<b>Shaft</b>	Material 1 C45, shaft ends greased Fit with ISO 6 tolerance with parallel keyway: according to DIN 6885 Sheet 1	See chapter 4.6.2
<b>Hollow shaft</b>	Material 1 C45, shafts greased Fit with ISO 7 tolerance with parallel keyway: according to DIN 6885 Sheet 1	See chapter 4.6.3
<b>Radial shaft seal ring</b>	NBR, form A	See chapter 4.8
<b>Ambient temperature</b>	-10°C to +90°C. The values of the performance tables are valid for +20°C	See chapter 4.9.3
<b>Circumferential backlash</b>	< 30 arcmin	See chapter 6.2.10
<b>Protection class</b>	IP 54	See chapter 4.5
<b>Corrosion protection</b>	Prime coat; layer thickness > 40 µm	See chapter 4.4.1
<b>Bearing life L10h</b>	more than 15,000h	See chapter 4.9.1
<b>Oil change intervals</b>	Not required if the oil temperature is kept < 90°C The lifetime of the bearings can be increased by the factor 1.5 if the oil is changed after the first 500 service hours and then every 5000 service hours.	See chapter 6.2.8
<b>Lubricants</b>	Synthetic lubricants	See chapter 6.2.8
<b>Flange</b>	Suited for the mounting of IEC motors	
<b>Coupling</b>	Three-piece claw coupling	

## Performance data

n <sub>1</sub> [rpm]	1:1			1.5:1			2:1			3:1			4:1			5:1			6:1								
	n <sub>2</sub> [rpm]	P <sub>1N</sub> [kW]	T <sub>2N</sub> [Nm]	n <sub>2</sub> [rpm]	P <sub>1N</sub> [kW]	T <sub>2N</sub> [Nm]	n <sub>2</sub> [rpm]	P <sub>1N</sub> [kW]	T <sub>2N</sub> [Nm]	n <sub>2</sub> [rpm]	P <sub>1N</sub> [kW]	T <sub>2N</sub> [Nm]	n <sub>2</sub> [rpm]	P <sub>1N</sub> [kW]	T <sub>2N</sub> [Nm]	n <sub>2</sub> [rpm]	P <sub>1N</sub> [kW]	T <sub>2N</sub> [Nm]	n <sub>2</sub> [rpm]	P <sub>1N</sub> [kW]	T <sub>2N</sub> [Nm]						
3000	3000	39.68	120	2000	24.91	113	1500	16.53	100	1000	12.12	110	750	8.51	103	600	6.61	100	500	5.18	94						
2400	2400	37.04	140	1600	22.22	126	1200	14.68	111	800	11.46	130	600	7.34	111	480	5.56	105	400	4.58	104						
1500	1500	26.78	162	1000	17.08	155	750	11.41	138	500	8.05	146	375	4.96	120	300	3.80	115	250	2.95	107						
1000	1000	20.28	184	667	12.87	175	500	8.38	152	333	5.87	160	250	3.75	136	200	2.73	124	167	2.06	112						
750	750	16.20	196	500	10.47	190	375	6.86	166	250	4.60	167	188	3.06	148	150	2.15	130	125	1.61	117						
500	500	11.46	208	333	7.34	200	250	4.96	180	167	3.20	174	125	2.12	154	100	1.50	136	83	1.09	119						
250	250	5.92	215	167	3.76	204	125	2.48	180	83	1.62	177	63	1.12	162	50	0.79	143	42	0.56	121						
50	50	1.21	220	33	0.76	210	25	0.50	180	17	0.34	180	13	0.23	170	10	0.17	150	8	0.11	120						
P <sub>1Nt</sub> [kW]		10.0			10.0			10.0			10.0			10.0			10.0			10.0							
T <sub>2max</sub> [Nm]		430			358			180			280			280			250			200							

## Permissible radial force F<sub>r2</sub> and axial force F<sub>a2</sub> on shaft N<sub>2</sub>

n <sub>2</sub> [rpm]	3000		1000		500		250		100		50	
T <sub>2N</sub> [Nm]	F <sub>r</sub> [N]	F <sub>a</sub> [N]	F <sub>r</sub> [N]	F <sub>a</sub> [N]	F <sub>r</sub> [N]	F <sub>a</sub> [N]	F <sub>r</sub> [N]	F <sub>a</sub> [N]	F <sub>r</sub> [N]	F <sub>a</sub> [N]	F <sub>r</sub> [N]	F <sub>a</sub> [N]
< 140	1300	650	1700	850	2000	1000	2500	1250	3000	1500	3800	1900
> 140	1082	541	1420	710	1670	835	2080	1040	2500	1250	3170	1585

## Inertia moments/mass

Inertia moment J<sub>1</sub> related to the fast-rotating shaft (N<sub>1</sub>)

Model	Inertia moment [kgcm <sup>2</sup> ]						
	1:1	1.5:1	2:1	3:1	4:1	5:1	6:1
A0	34.6752	23.0606	18.4863	16.3939	15.2904	14.8851	14.6758
B0	45.8411	28.2365	21.6470	17.4945	15.7845	15.3137	14.9457
C0	45.8411	28.2365	21.6470	17.4945	15.7845	15.3137	14.9457
D0	46.8232	28.6730	21.8926	17.6037	15.8459	15.3530	14.9729
EON	42.4047	26.7092	20.7879	17.1127	15.5697	15.1763	14.8502
EOS	48.8060	29.5543	22.3883	17.8240	15.9698	15.4323	15.0280
FO	46.4752	30.6161	22.2113	18.2717	16.4716	15.6611	15.2424
GO	58.9746	34.2563	27.0398	22.4708	16.8069	16.3204	15.9517
HO	58.9746	34.2563	27.0398	22.4708	16.8069	16.3204	15.9517
JO	59.9567	34.6928	27.2854	22.5800	16.8683	16.3597	15.9789
KON	55.5382	32.7290	26.1807	22.0890	16.5921	16.1830	15.8562
KOS	61.9395	35.5741	27.7811	22.8003	16.9922	16.4390	16.0340

Mass [kg]
24.0
23.5
23.5
24.0
23.0
23.7
28.0
27.7
27.7
28.2
27.2
27.9

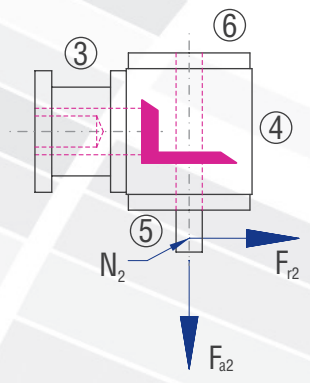



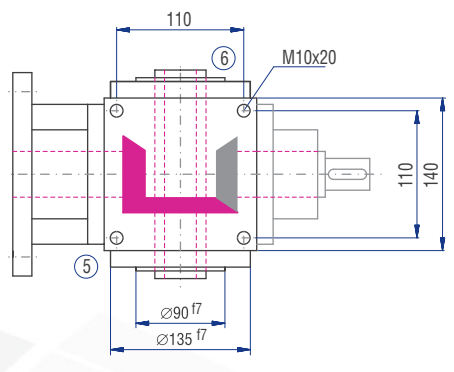
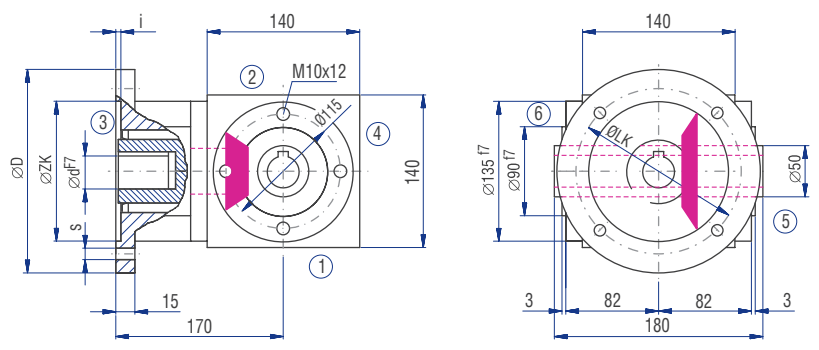

### Implementation

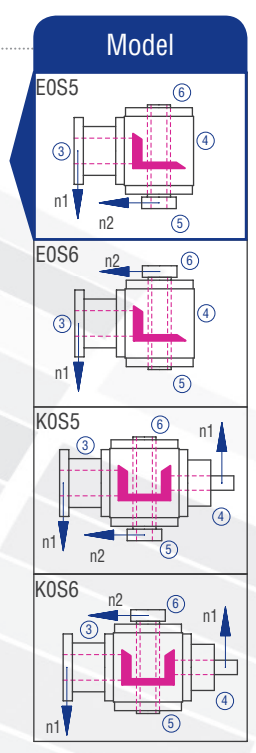
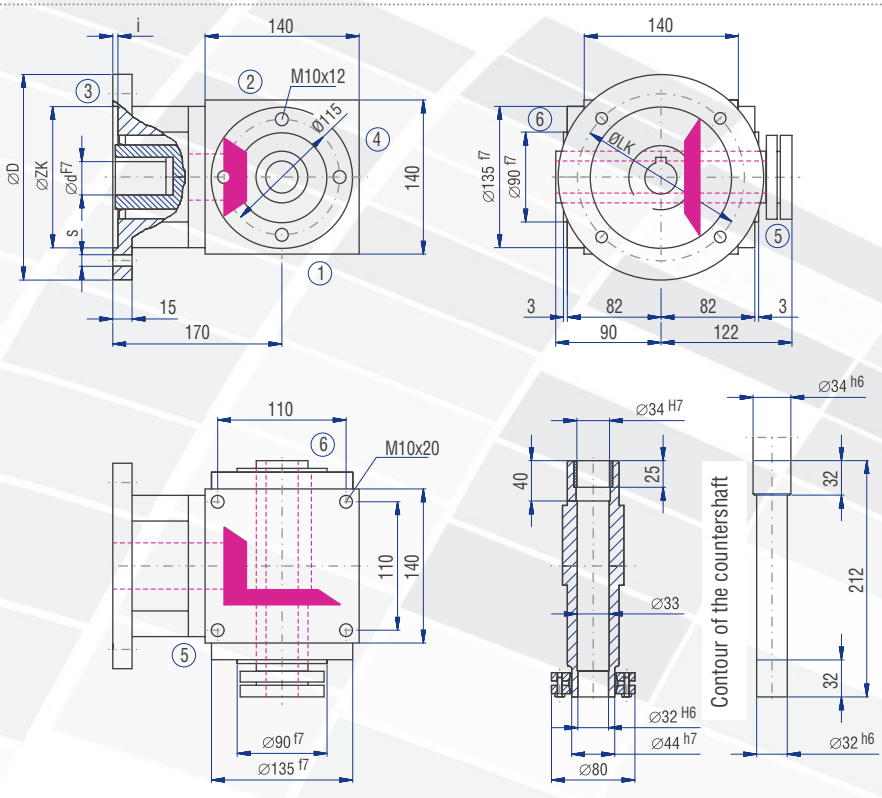
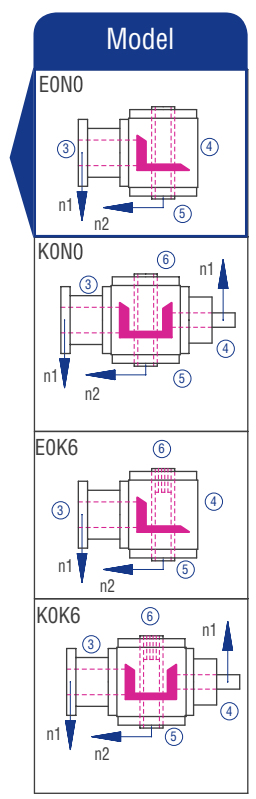
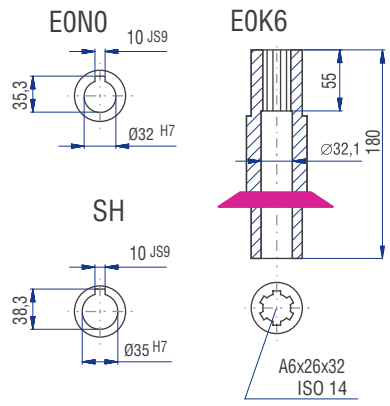

The dimensions of the Models not shown can be figured by mirroring available dimensions.  
The shaft dimensions on side 4 follow from the dimensions of type A0.

## 6.5.10 Type VL 160 – Type V with flange for motor mounting

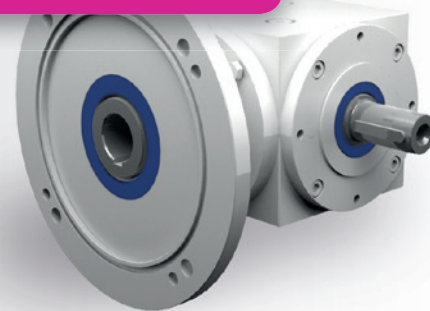

### Characteristics

Characteristic	Standard	Option
<b>Toothing</b>	Bevel gear set, spiral-toothed	See chapter 6.2.1
<b>Gear ratio</b>	1:1 to 6:1	
<b>Housing / Flanges</b>	Grey cast iron	
<b>Threaded mounting hole</b>	On all housing surfaces without flange and on all flanges.	See chapter 6.2.3
<b>Shaft</b>	Material 1 C45, shaft ends greased Fit with ISO 6 tolerance with parallel keyway: according to DIN 6885 Sheet 1	See chapter 4.6.2
<b>Hollow shaft</b>	Material 1 C45, shafts greased Fit with ISO 7 tolerance with parallel keyway: according to DIN 6885 Sheet 1	See chapter 4.6.3
<b>Radial shaft seal ring</b>	NBR, form A	See chapter 4.8
<b>Ambient temperature</b>	-10°C to +90°C. The values of the performance tables are valid for +20°C	See chapter 4.9.3
<b>Circumferential backlash</b>	< 30 arcmin	See chapter 6.2.10
<b>Protection class</b>	IP 54	See chapter 4.5
<b>Corrosion protection</b>	Prime coat; layer thickness > 40 µm	See chapter 4.4.1
<b>Bearing life L10h</b>	more than 15,000h	See chapter 4.9.1
<b>Oil change intervals</b>	Not required if the oil temperature is kept < 90°C The lifetime of the bearings can be increased by the factor 1.5 if the oil is changed after the first 500 service hours and then every 5000 service hours.	See chapter 6.2.8
<b>Lubricants</b>	Synthetic lubricants	See chapter 6.2.8
<b>Flange</b>	Suited for the mounting of IEC motors	
<b>Coupling</b>	Three-piece claw coupling	

## Performance data

n <sub>1</sub> [rpm]	1:1			1.5:1			2:1			3:1			4:1			5:1			6:1					
	n <sub>2</sub> [rpm]	P <sub>1N</sub> [kW]	T <sub>2N</sub> [Nm]	n <sub>2</sub> [rpm]	P <sub>1N</sub> [kW]	T <sub>2N</sub> [Nm]	n <sub>2</sub> [rpm]	P <sub>1N</sub> [kW]	T <sub>2N</sub> [Nm]	n <sub>2</sub> [rpm]	P <sub>1N</sub> [kW]	T <sub>2N</sub> [Nm]	n <sub>2</sub> [rpm]	P <sub>1N</sub> [kW]	T <sub>2N</sub> [Nm]	n <sub>2</sub> [rpm]	P <sub>1N</sub> [kW]	T <sub>2N</sub> [Nm]	n <sub>2</sub> [rpm]	P <sub>1N</sub> [kW]	T <sub>2N</sub> [Nm]			
3000				2000	40.78	185	1500	28.11	170	1000	20.94	190	750	14.88	180	600	11.90	180	500	7.09	129			
2400	2400	57.67	218	1600	36.15	205	1200	25.53	193	800	17.81	202	600	13.23	200	480	10.48	198	400	5.98	136			
1500	1500	42.99	260	1000	27.78	252	750	20.25	245	500	12.68	230	375	9.09	220	300	7.11	215	250	3.95	143			
1000	1000	31.96	290	667	20.59	280	500	14.88	270	333	8.99	245	250	6.61	240	200	4.96	225	167	3.01	164			
750	750	25.63	310	500	16.26	295	375	11.57	280	250	6.89	250	188	5.17	250	150	3.97	240	125	2.43	176			
500	500	18.19	330	333	11.56	315	250	8.27	300	167	4.79	260	125	3.58	260	100	2.76	250	83	1.72	187			
250	250	9.64	350	167	6.07	330	125	4.41	320	83	2.56	280	63	1.86	270	50	1.49	270	42	0.92	199			
50	50	2.09	380	33	1.29	355	25	0.88	320	17	0.57	305	13	0.39	280	10	0.32	290	8	0.18	197			
P <sub>1Nt</sub> [kW]		15.0			15.0			15.0			15.0			15.0			15.0			15.0				
T <sub>2max</sub> [Nm]		660			360			320			457			422			420			350				

## Permissible radial force F<sub>r2</sub> and axial force F<sub>a2</sub> on shaft N<sub>2</sub>

n <sub>2</sub> [rpm]	3000		1000		500		250		100		50	
T <sub>2N</sub> [Nm]	F <sub>r</sub> [N]	F <sub>a</sub> [N]	F <sub>r</sub> [N]	F <sub>a</sub> [N]	F <sub>r</sub> [N]	F <sub>a</sub> [N]	F <sub>r</sub> [N]	F <sub>a</sub> [N]	F <sub>r</sub> [N]	F <sub>a</sub> [N]	F <sub>r</sub> [N]	F <sub>a</sub> [N]
< 220	2000	1000	2800	1400	3300	1650	4000	2000	5000	2500	6500	3250
> 220	1670	835	2340	1170	2750	1375	3340	1670	4170	2085	5420	2710

## Inertia moments/mass

Inertia moment J<sub>1</sub> related to the fast-rotating shaft (N<sub>1</sub>)

Model	Inertia moment [kgcm <sup>2</sup> ]						
	1:1	1.5:1	2:1	3:1	4:1	5:1	6:1
AO	42.4880	32.2050	25.0090	22.8169	21.8333	21.4119	21.2266
BO	44.3697	44.5919	32.7507	25.9456	23.8183	22.8273	22.0772
CO	44.3697	44.5919	32.7507	25.9456	23.8183	22.8273	22.0772
DO	45.3990	45.0494	33.0080	26.0600	23.8826	22.8685	22.1058
EON	47.2021	45.7092	33.3159	26.1968	23.9596	22.9177	22.1413
EOS	53.4920	48.5047	34.8883	26.8957	24.3527	23.1693	22.3160
FO	57.3235	38.7985	28.7179	24.4653	22.7605	22.0053	21.6387
GO	59.2052	57.6357	41.4007	33.2488	29.3259	24.5072	23.7552
HO	59.2052	57.6357	41.4007	33.2488	29.3259	24.5072	23.7552
JO	60.2345	58.0932	41.6580	33.3632	29.3902	24.5484	23.7838
KON	62.0376	58.7530	41.9659	33.5000	29.4672	24.5976	23.8193
KOS	68.3275	61.5485	43.5383	34.1989	29.8603	24.8492	23.9940

Mass [kg]
36.5
36.0
36.0
36.5
35.0
35.6
43.0
42.5
42.5
43.0
41.5
42.1

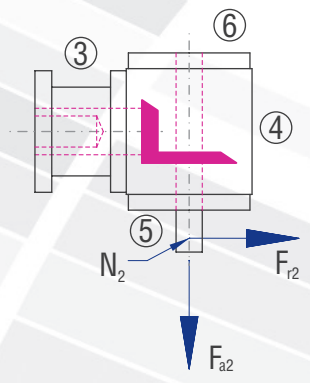



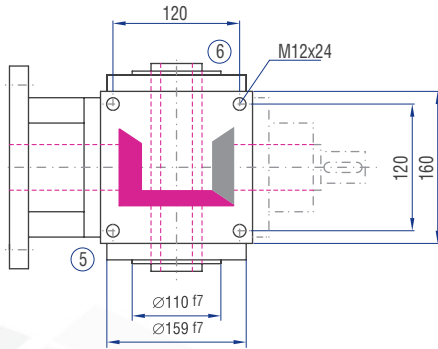
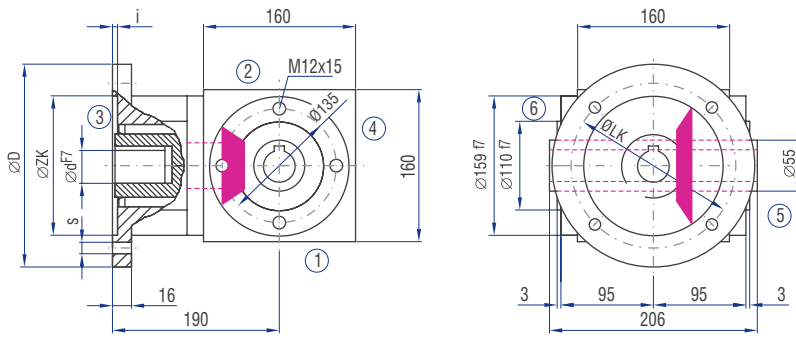

### Implementation

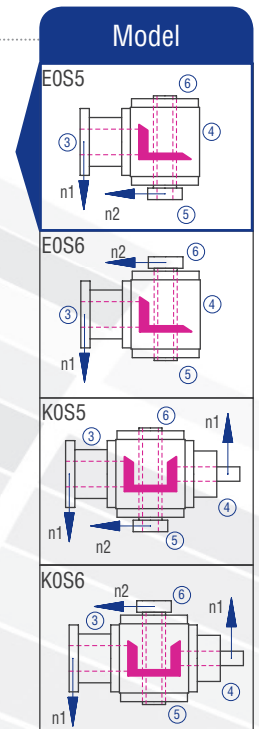
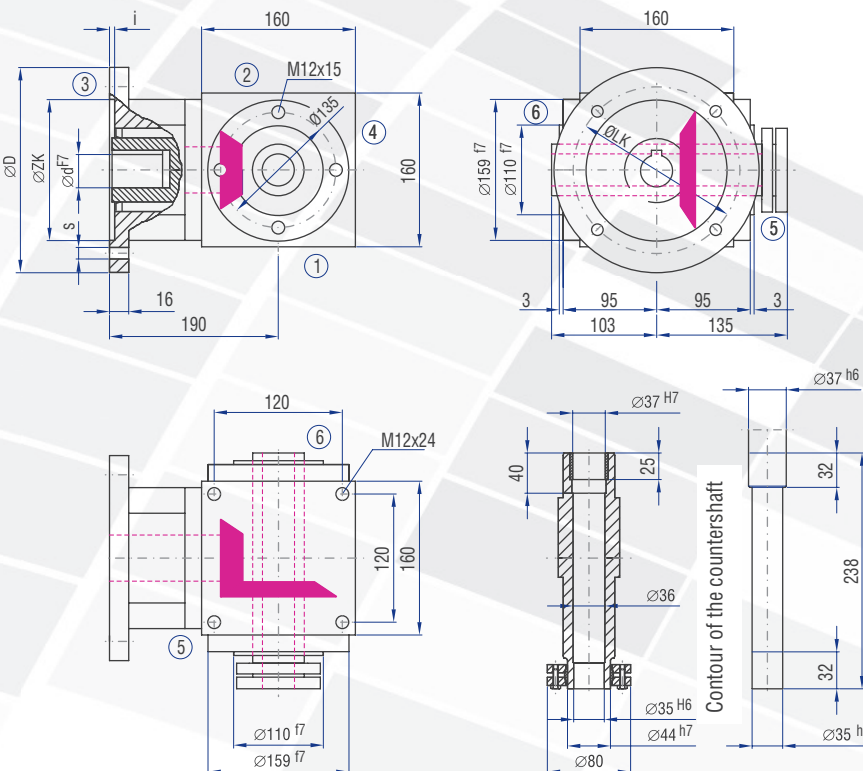
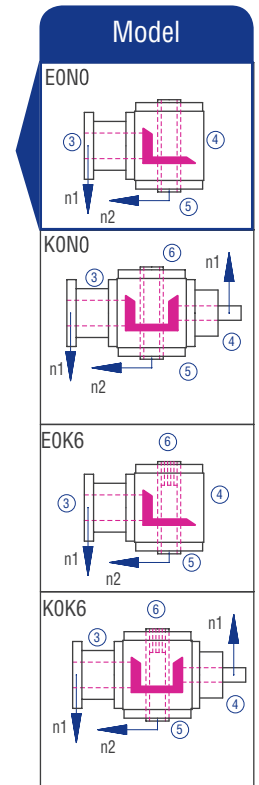
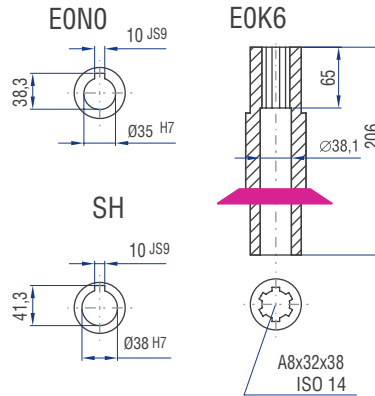

The dimensions of the Models not shown can be figured by mirroring available dimensions.  
The shaft dimensions on side 4 follow from the dimensions of type A0.

## 6.5.11 Type VL 200 – Type V with flange for motor mounting

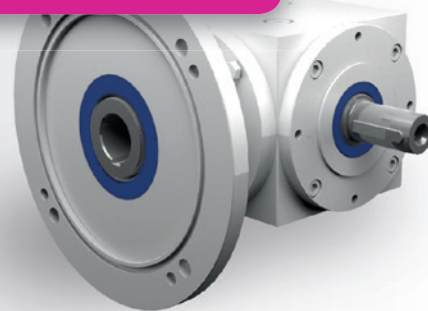

### Characteristics

Characteristic	Standard	Option
<b>Toothing</b>	Bevel gear set, spiral-toothed	See chapter 6.2.1
<b>Gear ratio</b>	1:1 to 6:1	
<b>Housing / Flanges</b>	Grey cast iron	
<b>Threaded mounting hole</b>	On all housing surfaces without flange and on all flanges.	See chapter 6.2.3
<b>Shaft</b>	Material 1 C45, shaft ends greased Fit with ISO 6 tolerance with parallel keyway: according to DIN 6885 Sheet 1	See chapter 4.6.2
<b>Hollow shaft</b>	Material 1 C45, shafts greased Fit with ISO 7 tolerance with parallel keyway: according to DIN 6885 Sheet 1	See chapter 4.6.3
<b>Radial shaft seal ring</b>	NBR, form A	See chapter 4.8
<b>Ambient temperature</b>	-10°C to +90°C. The values of the performance tables are valid for +20°C	See chapter 4.9.3
<b>Circumferential backlash</b>	< 30 arcmin	See chapter 6.2.10
<b>Protection class</b>	IP 54	See chapter 4.5
<b>Corrosion protection</b>	Prime coat; layer thickness > 40 µm	See chapter 4.4.1
<b>Bearing life L10h</b>	more than 15,000h	See chapter 4.9.1
<b>Oil change intervals</b>	Not required if the oil temperature is kept < 90°C The lifetime of the bearings can be increased by the factor 1.5 if the oil is changed after the first 500 service hours and then every 5000 service hours.	See chapter 6.2.8
<b>Lubricants</b>	Synthetic lubricants	See chapter 6.2.8
<b>Flange</b>	Suited for the mounting of IEC motors	
<b>Coupling</b>	Three-piece claw coupling	

## Performance data

n <sub>1</sub> [rpm]	1:1		1.5:1			2:1			3:1			4:1			5:1			6:1						
	n <sub>2</sub> [rpm]	P <sub>1N</sub> [kW]	T <sub>2N</sub> [Nm]	n <sub>2</sub> [rpm]	P <sub>1N</sub> [kW]	T <sub>2N</sub> [Nm]	n <sub>2</sub> [rpm]	P <sub>1N</sub> [kW]	T <sub>2N</sub> [Nm]	n <sub>2</sub> [rpm]	P <sub>1N</sub> [kW]	T <sub>2N</sub> [Nm]	n <sub>2</sub> [rpm]	P <sub>1N</sub> [kW]	T <sub>2N</sub> [Nm]	n <sub>2</sub> [rpm]	P <sub>1N</sub> [kW]	T <sub>2N</sub> [Nm]	n <sub>2</sub> [rpm]	P <sub>1N</sub> [kW]	T <sub>2N</sub> [Nm]			
3000				2000	72.75	330	1500	51.25	310	1000	46.29	420	750	28.93	350	600	19.84	300	500	11.45	208			
2400				1600	63.49	360	1200	45.24	342	800	39.24	445	600	26.45	400	480	17.99	340	400	9.60	218			
1500	1500	74.40	450	1000	48.17	437	750	35.13	425	500	28.38	515	375	18.81	455	300	12.57	380	250	6.54	237			
1000	1000	56.21	510	667	37.13	505	500	27.56	500	333	20.37	555	250	13.36	485	200	9.26	420	167	4.74	258			
750	750	45.88	555	500	30.31	550	375	21.90	530	250	15.98	580	188	10.54	510	150	7.27	440	125	3.98	289			
500	500	34.17	620	333	22.02	600	250	14.60	530	167	11.04	600	125	7.23	525	100	5.18	470	83	2.79	304			
250	250	19.56	710	167	11.04	600	125	7.30	530	83	5.76	630	63	3.79	550	50	2.78	505	42	1.44	311			
50	50	4.13	750	33	2.18	600	25	1.46	530	17	1.29	690	13	0.80	580	10	0.58	525	8	0.28	306			
<b>P<sub>1Nt</sub> [kW]</b>		26.0		26.0			26.0			26.0			26.0			26.0			26.0					
<b>T<sub>2max</sub> [Nm]</b>		1090		600			530			910			860			860			625					

## Permissible radial force F<sub>r2</sub> and axial force F<sub>a2</sub> on shaft N<sub>2</sub>

n <sub>2</sub> [rpm]	3000		1000		500		250		100		50	
T <sub>2N</sub> [Nm]	F <sub>r</sub> [N]	F <sub>a</sub> [N]	F <sub>r</sub> [N]	F <sub>a</sub> [N]	F <sub>r</sub> [N]	F <sub>a</sub> [N]	F <sub>r</sub> [N]	F <sub>a</sub> [N]	F <sub>r</sub> [N]	F <sub>a</sub> [N]	F <sub>r</sub> [N]	F <sub>a</sub> [N]
< 500	3200	1600	4300	2150	5000	2500	6500	3250	8000	4000	10000	5000
> 500	2670	1335	3580	1790	4170	2085	5420	2710	6670	3335	8330	4165

## Inertia moments/mass

Inertia moment J<sub>1</sub> related to the fast-rotating shaft (N<sub>1</sub>)

Model	Inertia moment [kgcm <sup>2</sup> ]						
	1:1	1.5:1	2:1	3:1	4:1	5:1	6:1
A0	160.794	103.333	79.4024	66.6041	62.5170	60.9854	60.2444
B0	214.242	149.221	114.714	81.9650	70.9700	67.7153	64.9180
C0	214.242	149.221	114.714	81.9650	70.9700	67.7153	64.9180
D0	217.359	150.606	115.494	82.3114	71.1649	67.8400	65.0046
E0N	240.932	154.665	119.527	82.9928	71.6107	68.6453	65.5638
E0S	261.954	164.009	124.783	85.3286	72.9245	69.4862	66.1478
F0	221.420	130.278	94.5590	73.3404	66.3062	63.4105	61.9285
G0	274.868	179.971	135.867	94.0610	81.4460	71.4373	68.6220
H0	274.868	179.971	135.867	94.0610	81.4460	71.4373	68.6220
J0	277.985	181.356	136.647	94.4074	81.6409	71.5620	68.7086
K0N	301.558	185.416	140.680	95.0888	82.0867	72.3673	69.2678
K0S	322.580	194.759	145.936	97.4246	83.4005	73.2082	69.8518

Mass [kg]
64.0
60.0
60.0
62.0
60.0
61.3
72.0
70.0
70.0
72.0
70.0
71.3

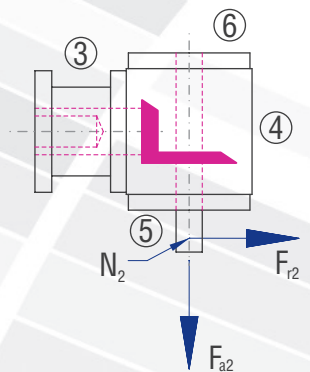

# 6.5.11 Type VL 200 – Type V with flange for motor mounting

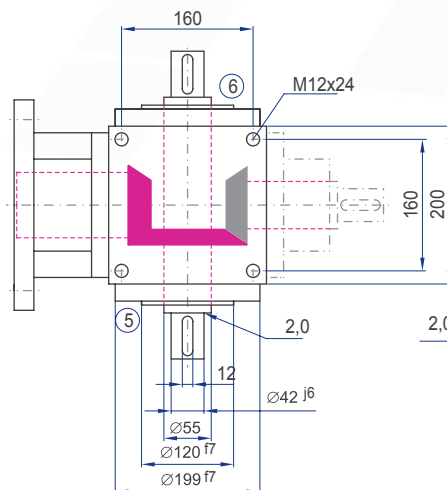
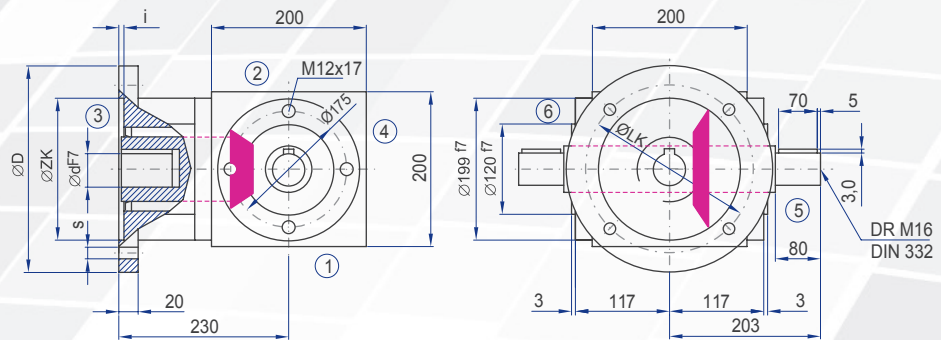
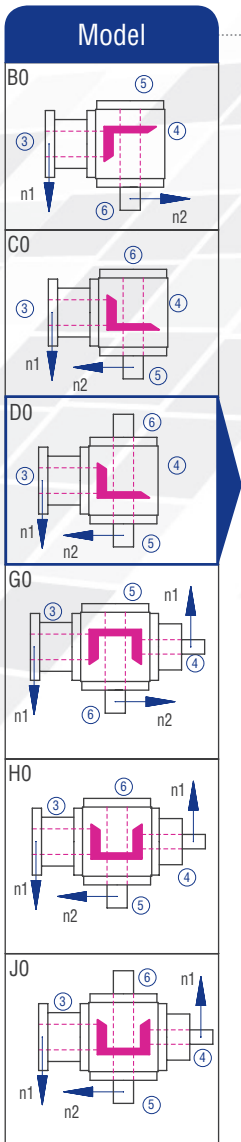
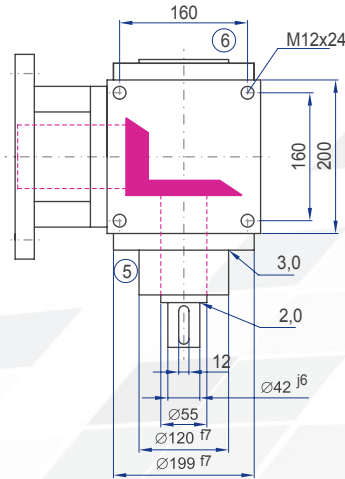
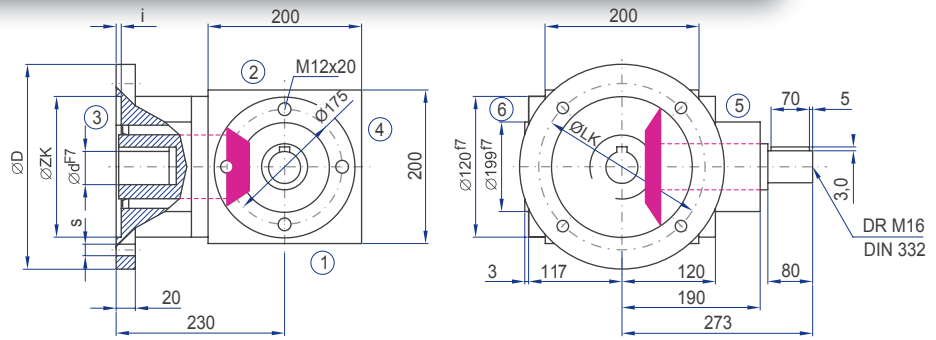
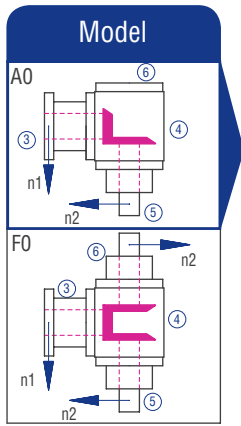

## Implementation VV

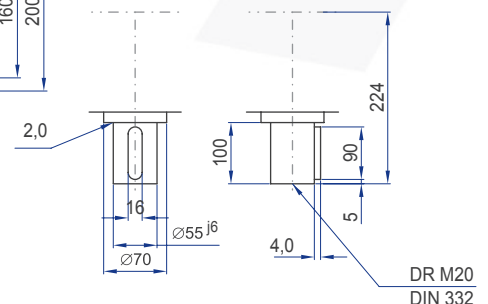

IEC motor	Model	Shaft (dxl)	D [mm]	LK [mm]	ZK [mm]	s [mm]	i [mm]
100	B14	28x60	200	165	130	11	4
	B5	28x60	250	215	180	14	5
112	B5	28x60	200	165	130	11	4
	B5	28x60	250	215	180	14	5
132	B14	38x80	200	165	130	11	4
	B5	38x80	300	265	230	14	5
160	B5	42x110	350	300	250	18	6
180	B5	48x110	350	300	250	18	6

Gear ratios 3:1 through 6:1 only with intermediate flange or shortened motor shaft.

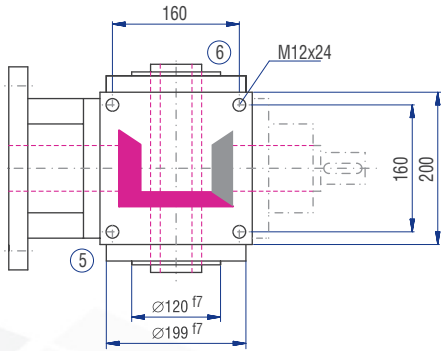
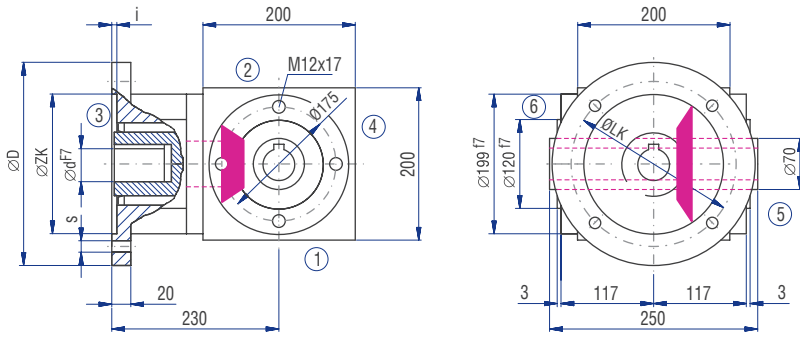

### Implementation

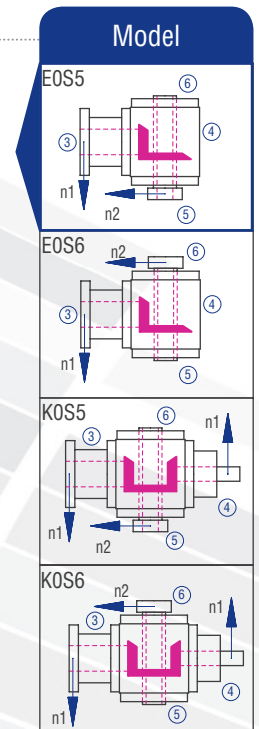
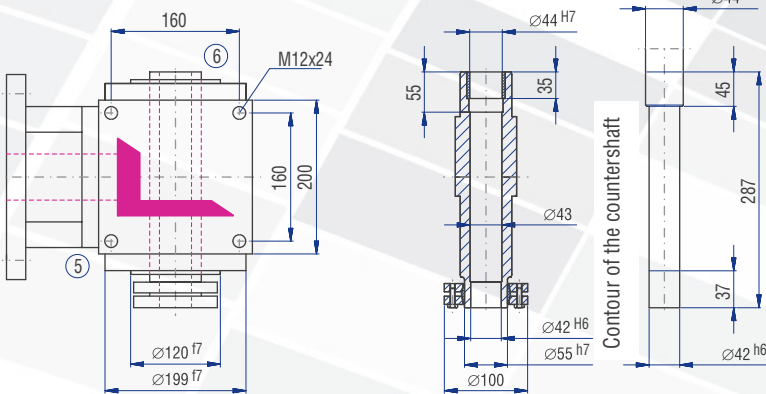
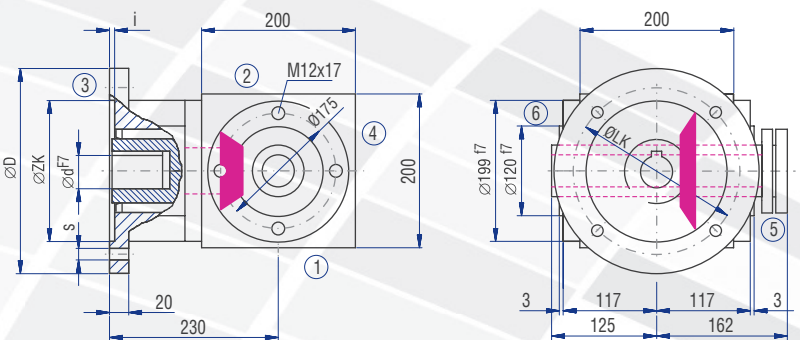
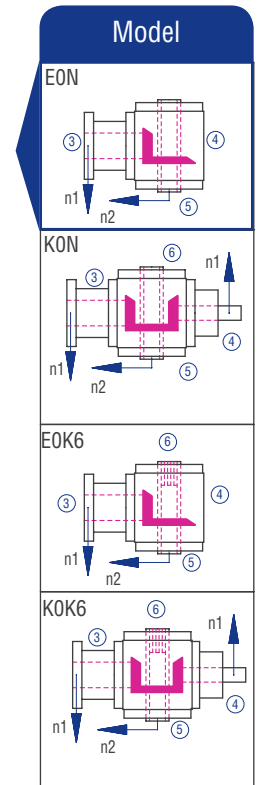
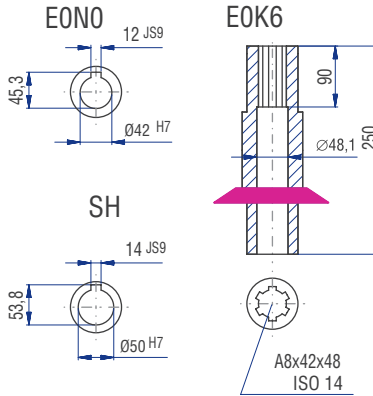

The dimensions of the Models not shown can be figured by mirroring available dimensions.  
The shaft dimensions on side 4 follow from the dimensions of type A0.

## 6.5.12 Type VL 230 – Type V with flange for motor mounting

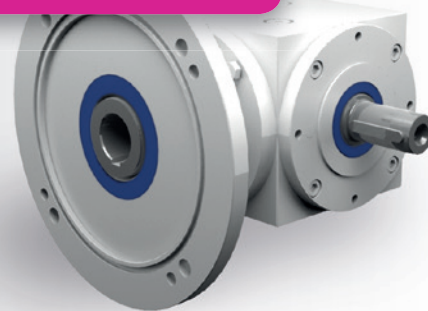

### Characteristics

Characteristic	Standard	Option
<b>Toothing</b>	Bevel gear set, spiral-toothed	See chapter 6.2.1
<b>Gear ratio</b>	1:1 to 6:1	
<b>Housing / Flanges</b>	Grey cast iron	
<b>Threaded mounting hole</b>	On all housing surfaces without flange and on all flanges.	See chapter 6.2.3
<b>Shaft</b>	Material 1 C45, shaft ends greased Fit with ISO 6 tolerance with parallel keyway: according to DIN 6885 Sheet 1	See chapter 4.6.2
<b>Hollow shaft</b>	Material 1 C45, shafts greased Fit with ISO 7 tolerance with parallel keyway: according to DIN 6885 Sheet 1	See chapter 4.6.3
<b>Radial shaft seal ring</b>	NBR, form A	See chapter 4.8
<b>Ambient temperature</b>	-10°C to +90°C. The values of the performance tables are valid for +20°C	See chapter 4.9.3
<b>Circumferential backlash</b>	< 30 arcmin	See chapter 6.2.10
<b>Protection class</b>	IP 54	See chapter 4.5
<b>Corrosion protection</b>	Prime coat; layer thickness > 40 µm	See chapter 4.4.1
<b>Bearing life L10h</b>	more than 15,000h	See chapter 4.9.1
<b>Oil change intervals</b>	Not required if the oil temperature is kept < 90°C The lifetime of the bearings can be increased by the factor 1.5 if the oil is changed after the first 500 service hours and then every 5000 service hours.	See chapter 6.2.8
<b>Lubricants</b>	Synthetic lubricants	See chapter 6.2.8
<b>Flange</b>	Suited for the mounting of IEC motors	
<b>Coupling</b>	Three-piece claw coupling	

## Performance data

n <sub>1</sub> [rpm]	1:1		1.5:1			2:1			3:1			4:1			5:1			6:1						
	n <sub>2</sub> [rpm]	P <sub>1N</sub> [kW]	T <sub>2N</sub> [Nm]	n <sub>2</sub> [rpm]	P <sub>1N</sub> [kW]	T <sub>2N</sub> [Nm]	n <sub>2</sub> [rpm]	P <sub>1N</sub> [kW]	T <sub>2N</sub> [Nm]	n <sub>2</sub> [rpm]	P <sub>1N</sub> [kW]	T <sub>2N</sub> [Nm]	n <sub>2</sub> [rpm]	P <sub>1N</sub> [kW]	T <sub>2N</sub> [Nm]	n <sub>2</sub> [rpm]	P <sub>1N</sub> [kW]	T <sub>2N</sub> [Nm]	n <sub>2</sub> [rpm]	P <sub>1N</sub> [kW]	T <sub>2N</sub> [Nm]			
3000				2000	99.20	450	1500	87.63	530	1000	44.09	400	750	36.37	440	600	33.73	510	500	20.17	366			
2400				1600	91.35	518	1200	80.02	605	800	39.68	450	600	32.74	495	480	29.10	550	400	18.08	410			
1500	1500	87.63	530	1000	72.20	655	750	59.11	715	500	29.76	540	375	24.80	600	300	21.00	635	250	13.50	490			
1000	1000	71.65	650	667	56.21	765	500	45.19	820	333	23.33	635	250	18.60	675	200	15.76	715	167	9.92	540			
750	750	60.76	735	500	45.47	825	375	36.79	890	250	19.29	700	188	15.19	735	150	12.73	770	125	7.78	565			
500	500	45.19	820	333	33.79	920	250	26.73	970	167	14.07	765	125	10.95	795	100	9.15	830	83	5.42	590			
250	250	26.73	970	167	20.57	1,120	125	16.88	1,225	83	7.58	825	63	5.99	870	50	5.07	920	42	2.82	610			
50	50	7.00	1,270	33	4.89	1,330	25	3.66	1,330	17	1.63	870	13	1.35	980	10	1.09	990	8	0.57	625			
P <sub>1Nt</sub> [kW]		34.0		34.0			34.0			34.0			34.0			34.0			34.0					
T <sub>2max</sub> [Nm]		1500		1400			1400			1300			1300			1200			1000					

## Permissible radial force F<sub>r2</sub> and axial force F<sub>a2</sub> on shaft N<sub>2</sub>

n <sub>2</sub> [rpm]	3000		1000		500		250		100		50	
T <sub>2N</sub> [Nm]	F <sub>r</sub> [N]	F <sub>a</sub> [N]	F <sub>r</sub> [N]	F <sub>a</sub> [N]	F <sub>r</sub> [N]	F <sub>a</sub> [N]	F <sub>r</sub> [N]	F <sub>a</sub> [N]	F <sub>r</sub> [N]	F <sub>a</sub> [N]	F <sub>r</sub> [N]	F <sub>a</sub> [N]
< 750	5850	2925	8650	4325	10500	5250	12250	6125	15000	7500	19000	9500
> 750	4876	2438	7208	3604	8750	4375	10208	5104	12500	6250	15830	7915

## Inertia moments/mass

Inertia moment J<sub>1</sub> related to the fast-rotating shaft (N<sub>1</sub>)

Model	Inertia moment [kgcm <sup>2</sup> ]							Mass [kg]
	1:1	1.5:1	2:1	3:1	4:1	5:1	6:1	
AO	577.000	287.000	203.000	141.000	134.000	131.000	126.000	94.0
BO	573.000	292.000	207.000	143.000	135.000	131.000	127.000	112.0
CO	573.000	292.000	207.000	143.000	135.000	131.000	127.000	112.0
DO	583.000	296.000	209.000	144.000	135.000	132.000	127.000	91.0
EON	583.000	301.000	213.000	146.000	136.000	132.000	127.000	86.0
EOS	644.000	328.000	228.000	153.000	140.000	135.000	129.000	87.0
FO	830.000	404.000	272.000	163.000	149.000	142.000	134.000	112.0
GO	826.000	390.000	271.000	177.000	168.000	161.000	157.000	115.0
HO	826.000	390.000	271.000	177.000	168.000	161.000	157.000	115.0
JO	836.000	394.000	273.000	178.000	168.000	162.000	157.000	117.0
KON	836.000	399.000	277.000	180.000	169.000	162.000	157.000	110.0
KOS	897.000	426.000	292.000	187.000	173.000	165.000	159.000	111.0

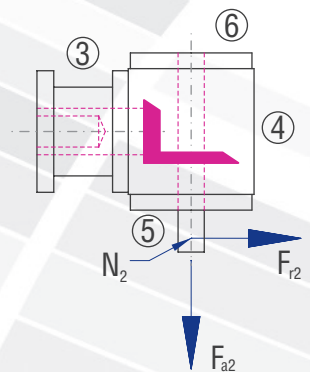

# 6.5.12 Type VL 230 – Type V with flange for motor mounting

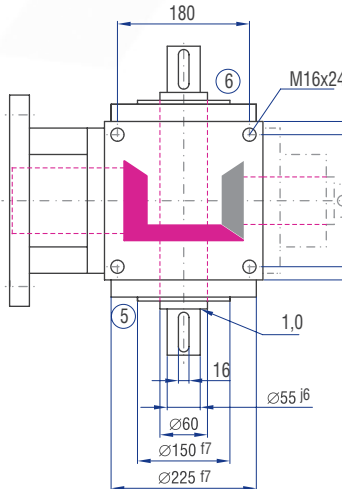
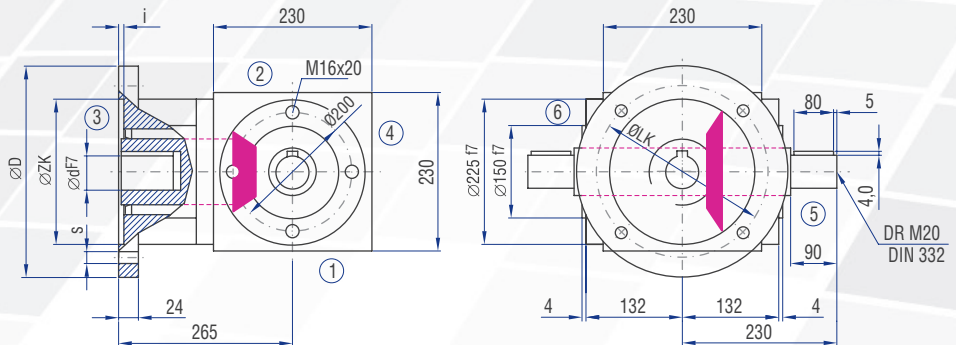
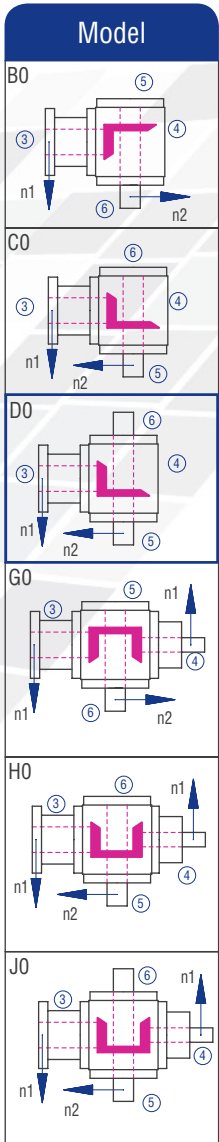
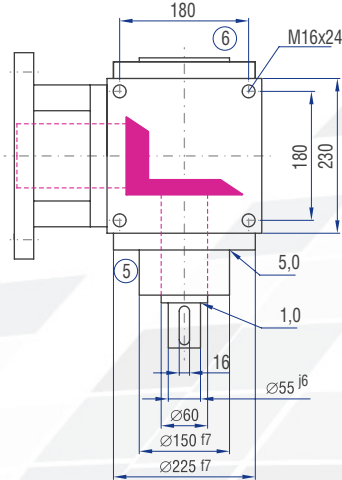
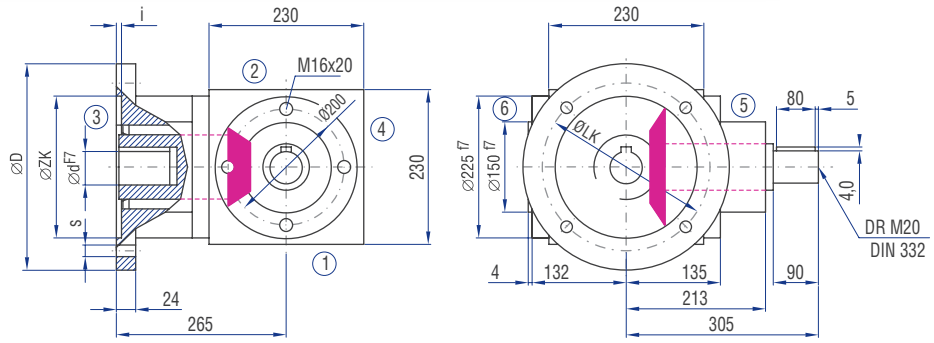
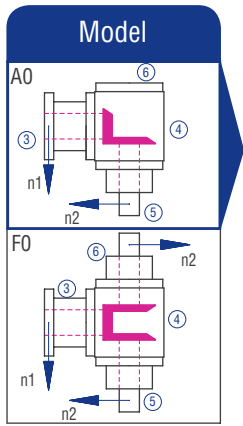

## Implementation VV

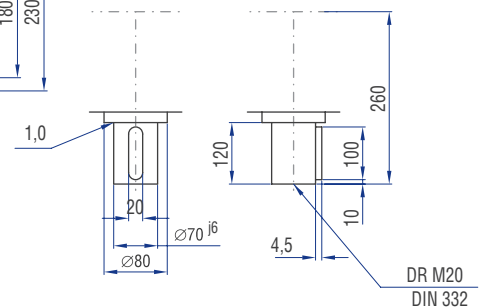

IEC motor	Model	Shaft (dxL)	D [mm]	LK [mm]	ZK [mm]	s [mm]	i [mm]
132	B5	38x80	300	265	230	14	5
160	B5	42x110	350	300	250	18	6
180	B5	48x110	350	300	250	18	6
200	B5	55x110	400	350	300	18	6

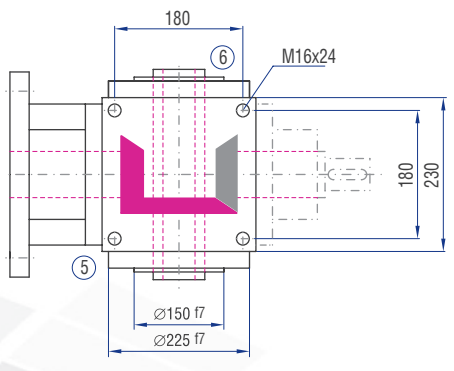
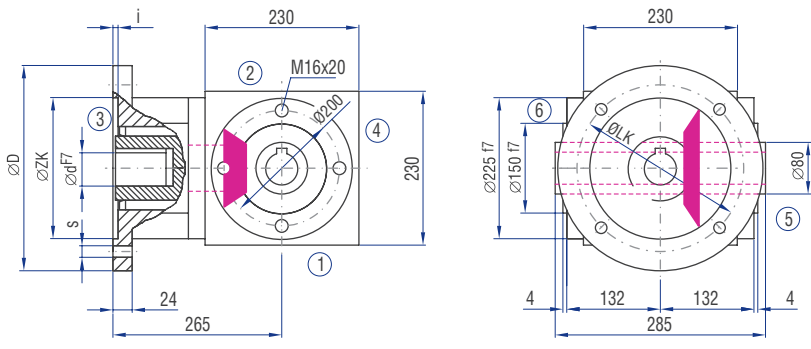

### Implementation

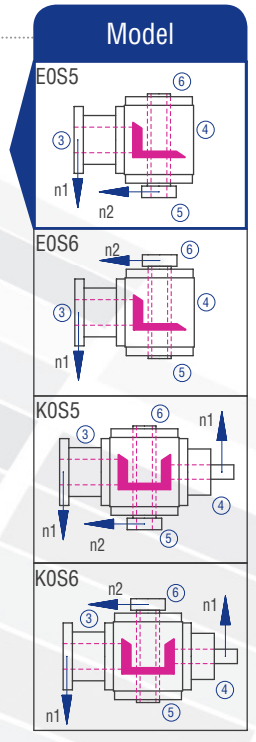
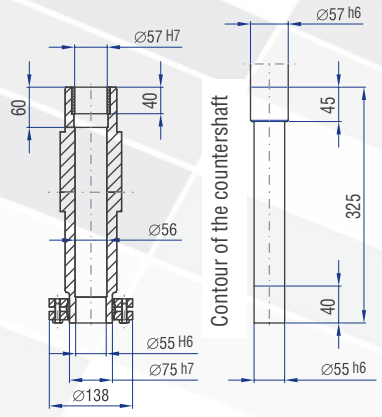
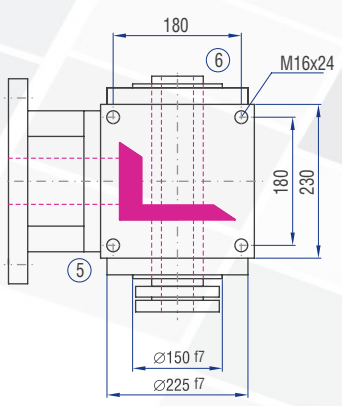
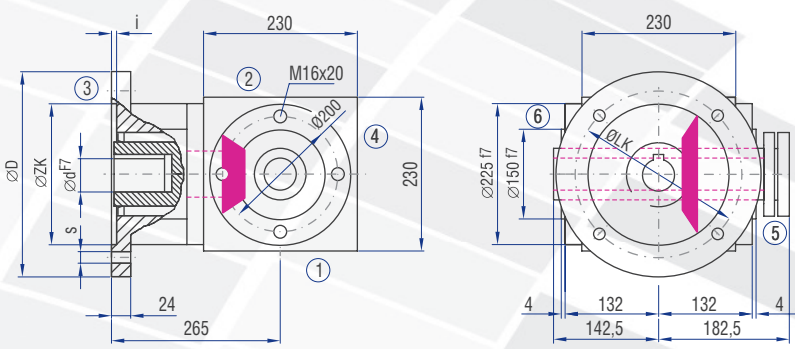
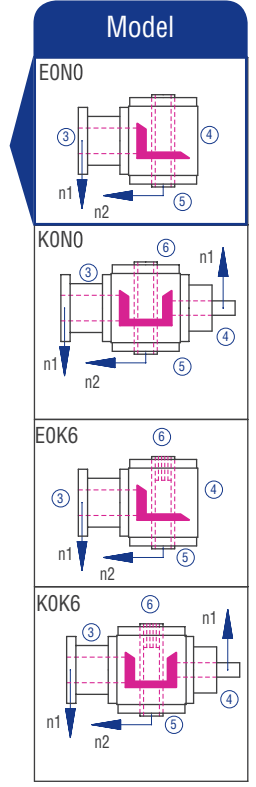
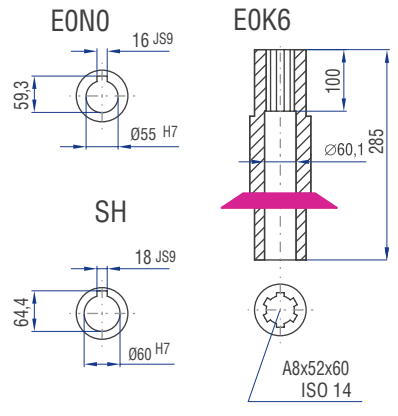

The dimensions of the Models not shown can be figured by mirroring available dimensions.  
The shaft dimensions on side 4 follow from the dimensions of type A0.

## 6.5.13 Type VL 260 – Type V with flange for motor mounting

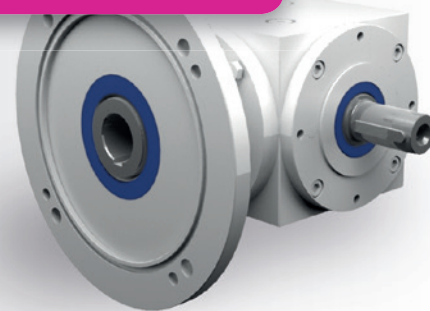

### Characteristics

Characteristic	Standard	Option
<b>Toothing</b>	Bevel gear set, spiral-toothed	See chapter 6.2.1
<b>Gear ratio</b>	1:1 to 6:1	
<b>Housing / Flanges</b>	Grey cast iron	
<b>Threaded mounting hole</b>	On all housing surfaces without flange and on all flanges.	See chapter 6.2.3
<b>Shaft</b>	Material 1 C45, shaft ends greased Fit with ISO 6 tolerance with parallel keyway: according to DIN 6885 Sheet 1	See chapter 4.6.2
<b>Hollow shaft</b>	Material 1 C45, shafts greased Fit with ISO 7 tolerance with parallel keyway: according to DIN 6885 Sheet 1	See chapter 4.6.3
<b>Radial shaft seal ring</b>	NBR, form A	See chapter 4.8
<b>Ambient temperature</b>	-10°C to +90°C. The values of the performance tables are valid for +20°C	See chapter 4.9.3
<b>Circumferential backlash</b>	< 30 arcmin	See chapter 6.2.10
<b>Protection class</b>	IP 54	See chapter 4.5
<b>Corrosion protection</b>	Prime coat; layer thickness > 40 µm	See chapter 4.4.1
<b>Bearing life L10h</b>	more than 15,000h	See chapter 4.9.1
<b>Oil change intervals</b>	Not required if the oil temperature is kept < 90°C The lifetime of the bearings can be increased by the factor 1.5 if the oil is changed after the first 500 service hours and then every 5000 service hours.	See chapter 6.2.8
<b>Lubricants</b>	Synthetic lubricants	See chapter 6.2.8
<b>Flange</b>	Suited for the mounting of IEC motors	
<b>Coupling</b>	Three-piece claw coupling	

## Performance data

n <sub>1</sub> [rpm]	1:1		1.5:1			2:1			3:1			4:1			5:1			6:1						
	n <sub>2</sub> [rpm]	P <sub>1N</sub> [kW]	T <sub>2N</sub> [Nm]	n <sub>2</sub> [rpm]	P <sub>1N</sub> [kW]	T <sub>2N</sub> [Nm]	n <sub>2</sub> [rpm]	P <sub>1N</sub> [kW]	T <sub>2N</sub> [Nm]	n <sub>2</sub> [rpm]	P <sub>1N</sub> [kW]	T <sub>2N</sub> [Nm]	n <sub>2</sub> [rpm]	P <sub>1N</sub> [kW]	T <sub>2N</sub> [Nm]	n <sub>2</sub> [rpm]	P <sub>1N</sub> [kW]	T <sub>2N</sub> [Nm]	n <sub>2</sub> [rpm]	P <sub>1N</sub> [kW]	T <sub>2N</sub> [Nm]			
3000				2000	189.58	860	1500	133.92	810	1000	85.97	780	750	57.87	700	600	46.29	700	500	27.27	495			
2400				1600	158.72	900	1200	112.43	850	800	72.39	821	600	51.58	780	480	40.21	760	400	23.12	524			
1500	1500	157.07	950	1000	104.71	950	750	78.53	950	500	49.60	900	375	37.20	900	300	29.10	880	250	16.36	594			
1000	1000	115.73	1,050	667	73.50	1,000	500	57.87	1,050	333	36.34	990	250	28.93	1,050	200	21.82	990	167	12.93	702			
750	750	96.72	1,170	500	55.11	1,000	375	48.36	1,170	250	28.93	1,050	188	22.73	1,100	150	18.19	1,100	125	10.91	792			
500	500	72.75	1,320	333	36.70	1,000	250	33.07	1,200	167	20.43	1,110	125	16.26	1,180	100	13.23	1,200	83	8.06	878			
250	250	42.44	1,540	167	18.40	1,000	125	16.53	1,200	83	11.16	1,220	63	8.61	1,250	50	7.11	1,290	42	4.35	940			
50	50	9.64	1,750	33	3.64	1,000	25	3.31	1,200	17	2.55	1,360	13	1.82	1,320	10	1.47	1,330	8	0.87	951			
P <sub>1Nt</sub> [kW]		42.0		42.0			42.0			42.0			42.0			42.0			42.0					
T <sub>2max</sub> [Nm]		2310		1000			1200			1940			1940			1910			1730					

## Permissible radial force F<sub>r2</sub> and axial force F<sub>a2</sub> on shaft N<sub>2</sub>

n <sub>2</sub> [rpm]	3000		1000		500		250		100		50	
T <sub>2N</sub> [Nm]	F <sub>r</sub> [N]	F <sub>a</sub> [N]	F <sub>r</sub> [N]	F <sub>a</sub> [N]	F <sub>r</sub> [N]	F <sub>a</sub> [N]	F <sub>r</sub> [N]	F <sub>a</sub> [N]	F <sub>r</sub> [N]	F <sub>a</sub> [N]	F <sub>r</sub> [N]	F <sub>a</sub> [N]
< 950	8500	4250	13000	6500	16000	8000	18000	9000	22000	11000	28000	14000
> 950	7080	3540	10830	5415	13330	6665	15000	7500	18330	9165	23330	11665

## Inertia moments/mass

Inertia moment J<sub>1</sub> related to the fast-rotating shaft (N<sub>1</sub>)

Model	Inertia moment [kgcm <sup>2</sup> ]							Mass [kg]
	1:1	1.5:1	2:1	3:1	4:1	5:1	6:1	
A0	826.100	347.183	202.675	136.373	115.804	105.534	100.558	100.0
B0	839.340	209.512	289.735	168.511	135.694	118.264	109.454	100.0
C0	839.340	209.512	289.735	168.511	135.694	118.264	109.454	100.0
D0	853.750	424.806	293.338	103.557	136.594	118.840	109.854	103.0
E0N	840.590	454.512	296.298	171.400	137.319	119.304	110.176	97.0
E0S	904.240	482.801	312.210	178.470	141.296	121.849	111.944	99.9
F0	1233.20	528.117	304.450	181.607	141.248	121.818	111.867	120.0
G0	1246.44	334.512	382.235	208.361	157.024	139.264	129.954	124.0
H0	1246.44	334.512	382.235	208.361	157.024	139.264	129.954	124.0
J0	1260.85	549.806	385.838	143.407	157.924	139.840	130.354	127.0
K0N	1247.69	579.512	388.798	211.250	158.649	140.304	130.676	121.0
K0S	1311.34	607.801	404.710	218.320	162.626	142.849	132.444	123.9

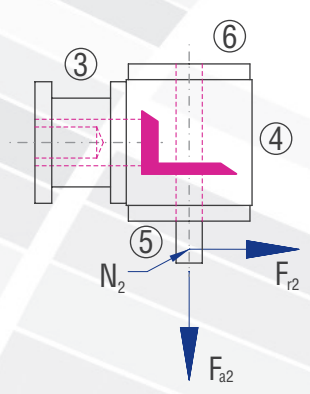

# 6.5.13 Type VL 260 – Type V with flange for motor mounting

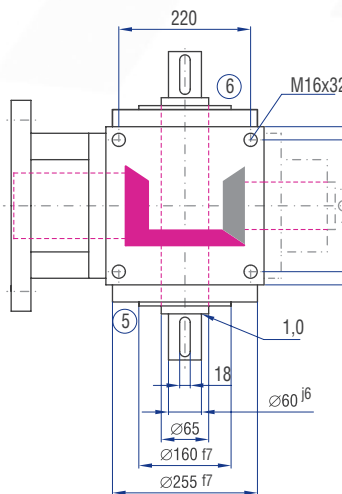
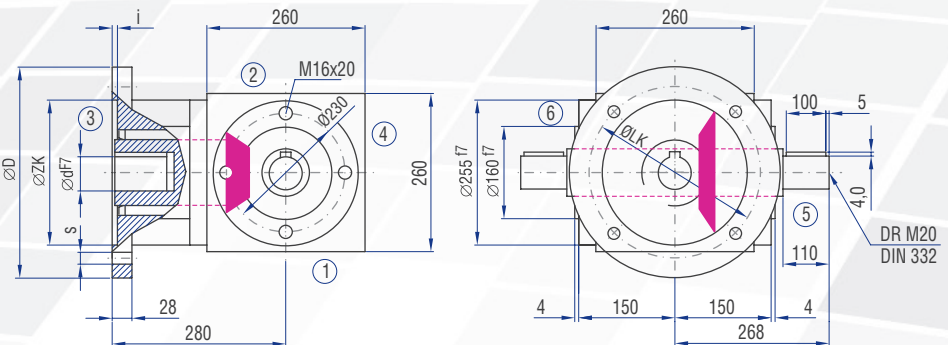
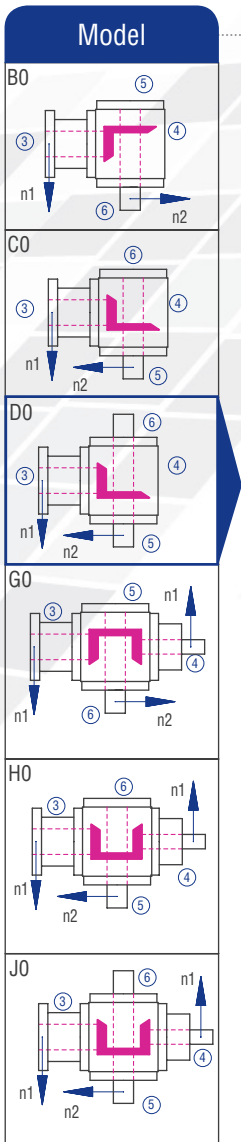
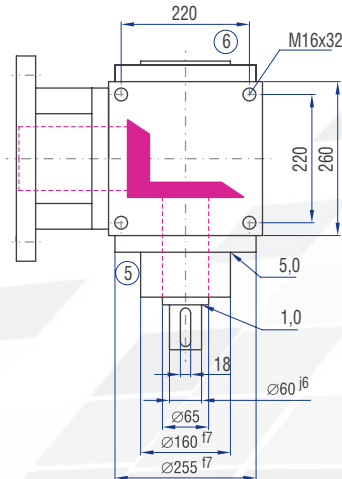
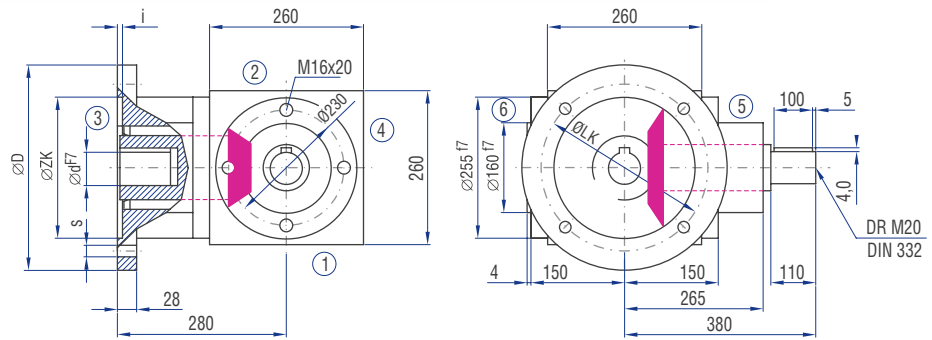
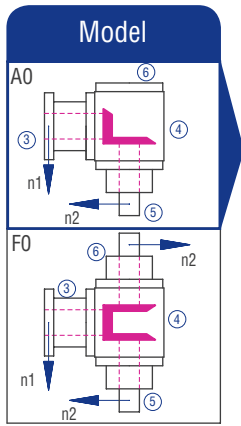

## Implementation VV

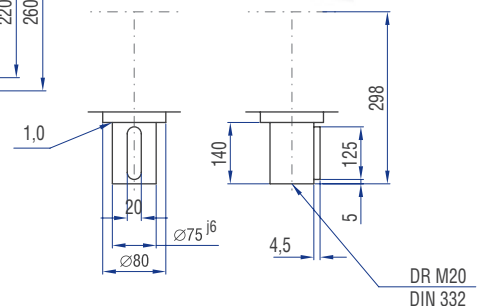

IEC motor	Model	Shaft (dxl)	D [mm]	LK [mm]	ZK [mm]	s [mm]	i [mm]
132	B5	38x80	300	265	230	14	5
160	B5	42x110	350	300	250	18	6
180	B5	48x110	350	300	250	18	6
200	B5	55x110	400	350	300	18	6

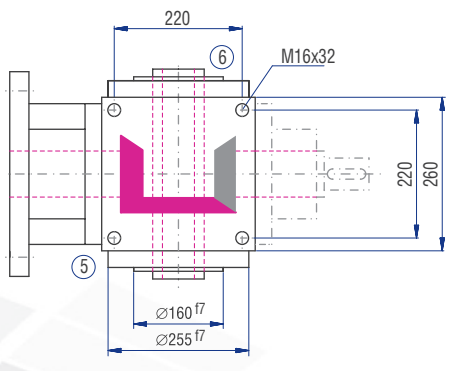
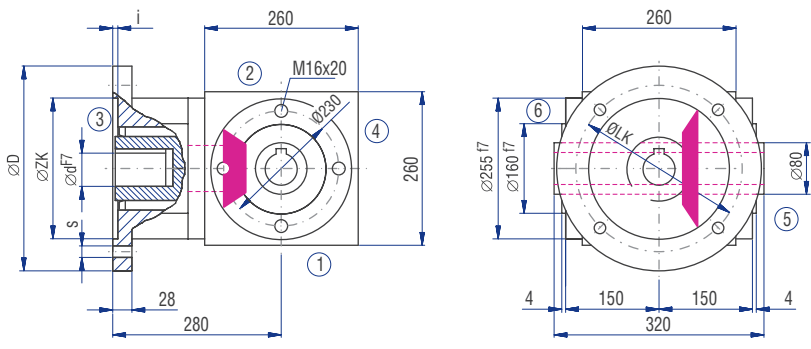

### Implementation

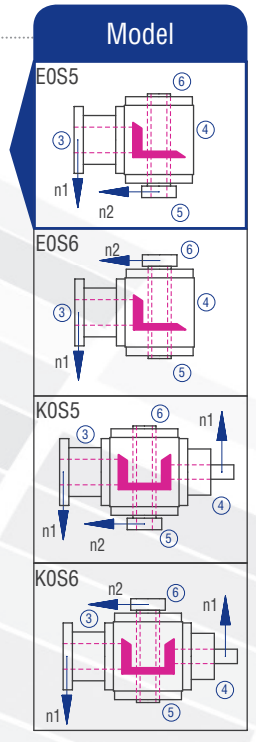
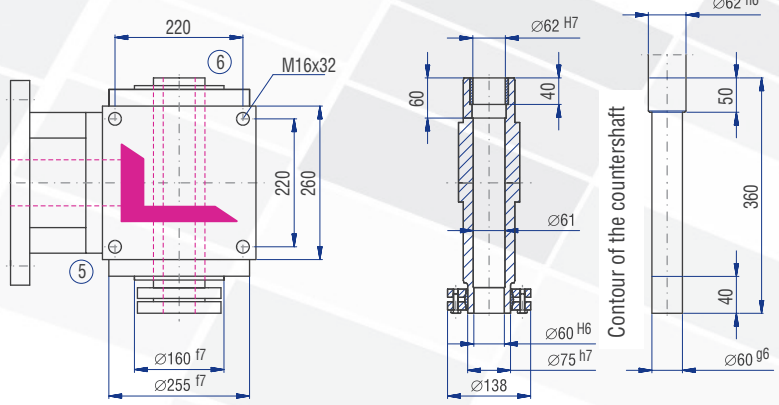
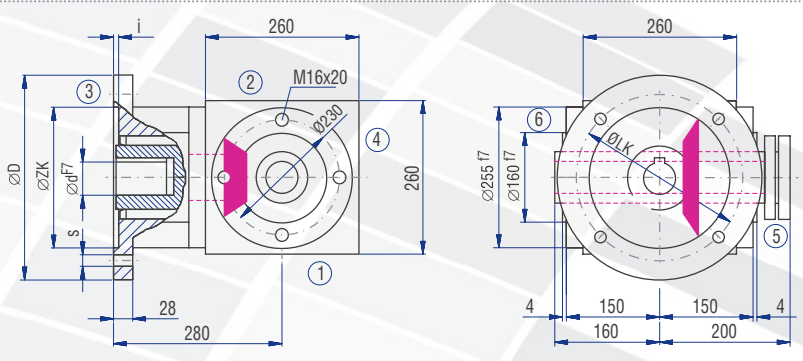
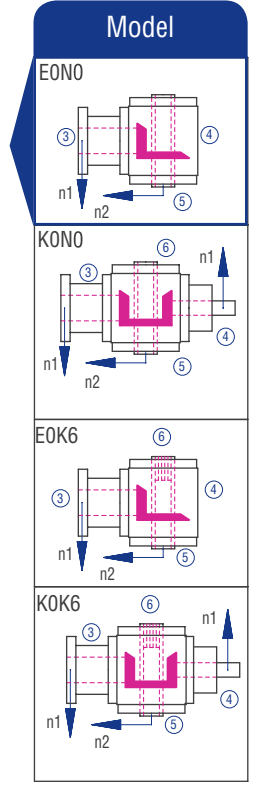
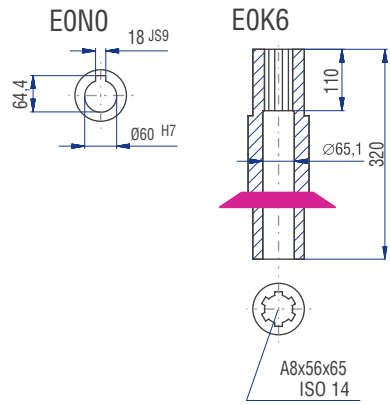

The dimensions of the Models not shown can be figured by mirroring available dimensions.  
The shaft dimensions on side 4 follow from the dimensions of type A0.

# 6.6 Multi shaft bevel gearboxes – with additional shafts

## 6.6.1 Features

for gear ratios of 1.5:1 to 6:1 with type V  
 for gear ratios of 1.5:1 to 2:1 with type VS  
 with solid shaft or hollow shaft  
 up to 6 shaft ends



		Type V		Type VS	
<b>A1</b>			<b>B1</b>		
<b>F1</b>			<b>C1</b>		
<b>F2</b>			<b>D1</b>		
<b>F3</b>			<b>H1</b>		

The modular system of our bevel gearboxes makes it possible to manufacture a variety of type variants. In the standard gearboxes, the shafts are always arranged in one plane. In Multi shaft gearboxes, additional shafts can be arranged perpendicular to this plane. The dimensions and permissible loads correspond to the standard types. The power flow is defined by the application. The gear ratio of 1:1 is only possible with type F2 (\*). Apart from that, all gear ratios are available. Only one gear ratio may be realised within one gearbox.

Type V		Type VS	
		<b>H2</b> 	
<b>F4</b> 		<b>G1</b> 	
<b>E1</b> 		<b>G2</b> 	
<b>K1</b> 		<b>J1</b> 	
<b>K2</b> 		<b>J2</b> 	