

5.1 Type overview



Type L – Miniature bevel gearboxes

Gear ratios: $i = 1:1$ to $4:1$
Maximum output torque: 16 Nm
2 gearbox sizes with edge lengths of 035 to 045 mm
Low-backlash construction < 10 angular minutes possible
Housing made of aluminium

5.2 General construction

The axles intersect in the gearbox in an angle of 90°.

Housing and cover(s) are made of aluminium. Upon request, the aluminium parts can be anodised.

The edge length of the housing is reflected in the gearbox size (example: L 035 – housing edge length 35 mm).

Toothing

ATEK bevel gearboxes have gear sets with high-quality spiral toothing made of hardened carburised steel. A gear set comprises one bevel pinion (small number of teeth / small diameter) and one bevel gear (large number of teeth / large diameter).

Gear sets with spiral toothing offer the advantage of very favourable engagement factors (high meshing ratio). Therefore they are predestined for usage with high loads, combined with optimal running smoothness and high transmission accuracy.

5.2.1 Construction types

Due to the modular system, different gearbox construction types can be configured.

The construction types vary in:

Construction type	consists of:	
A0 through E0	1 gear set	
F0 through K0	1 gear set	+ 1 bevel pinion or bevel gear
Branch-off gearbox	1 gear set	+ 2–3 bevel pinions/gears

Table 5.2.1-1

The variants differ in type and number of the shafts, the rotational direction of the shafts and their support by bearings.

5.2.2 Threaded mounting holes

All 6 sides of the gearboxes are machined and may be used as mounting surfaces. All flanges always have threaded mounting holes. You have the following available ordering options:

Order code	Threaded mounting holes are in the housing surfaces on the gearbox side	Threaded mounting holes are in the flanges on the gearbox side
0	-	3, 5, 6
1, 2, 3, 4, 5, 6	1, 2, 4	3, 5, 6
9	1, 2, 4	3, 5, 6

Table 5.2.2-1

The standard version of the mounting / fastening has the order code 9.

Example of order code: L 045 1:1 D0 9

Please enquire other mounting options.

5.2.3 Installation position

The gearboxes can be used in all installation positions. The recommended installation position is the position in which the shafts are horizontal. These are the installation positions 1 and 2. The installation position is defined by the gearbox side directed downwards during operation and will be indicated by the corresponding gearbox side. Please contact us for consultation if the angle of the gearbox side directed downwards deviates more than 15° from the horizontal position.

5 Miniature bevel gearboxes

5.2.4 Shaft designation – allocation to the gearbox sides

The fast-rotating shaft has the speed n_1 and is identified by N_1 . The bevel pinion is located on this shaft. The slowly rotating shaft has the speed n_2 and is identified by N_2 . The bevel gear is located on this shaft. The gearbox sides are identified by the numerals 1 to 6. (See Figure 4.3.1-1; Gearbox sides)

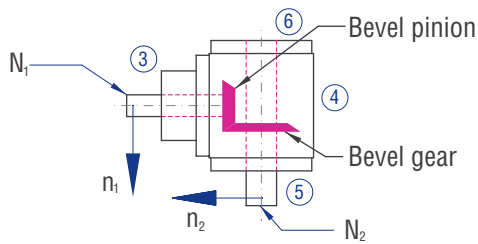

Figure 5.2.4-1; Shaft designations

5.2.5 Preferred direction of rotation

If the clockwise (CW) direction of rotation (viewing direction from shaft end face of the fast-rotating shaft towards the gearbox centre) is selected, a 1 to 2 dB(A) lower noise level is generated.

5.2.6 Efficiency

The achievable efficiency depends on rotational speed, torque, installation position, sealing, and lubricant type. With gearboxes having only one gear set, an efficiency of 97% can be achieved. With gearboxes having several gear meshings, an efficiency of 94% can be achieved. The efficiencies specified in the tables relate to the permissible nominal load and are guidance values for run-in gearboxes at operating temperature with standard sealing and filled with oil of viscosity grade 220.

5.2.7 Lubrication

The L-series gearboxes have lifetime lubrication.

5.2.8 Vent filter

No venting is provided for the miniature gearboxes.

5.2.9 Low-backlash construction

For low-friction running, the tooth space in the gear set is manufactured larger than the tooth. When the direction of rotation is changed, this results in a rotation angle until the counter-rotating tooth flanks contact each other. This rotation angle is called circumferential backlash.

Circumferential backlash, measuring method

The circumferential backlash is measured after the drive shaft (N_1) has been fixed. A force of around 2% of the nominal torque is applied to the output shaft (N_2) in both rotational directions. A tooth backlash will result between the two final positions. This can be measured as rotation angle and is indicated in minutes of arc [arcmin].

Circumferential backlash, type

Ordering option	Gear set	1:1; 2:1	3:1; 4:1
/0000	Standard	≤ 30 arcmin	≤ 30 arcmin
/S2	Standard	≤ 10 arcmin	≤ 12 arcmin
/S1	Standard	u.r.	u.r.
/S0	Special gear set	u.r.	u.r.

Table 5.2.9-1

Abbreviation: u.r. = upon request

5.2.10 Corrosion protection

A coloured anodic coating can be applied to the housing and flanges (See chapter 4.4.7). Please enquire the possible colours.

5.3 Type L – Miniature bevel gearboxes

5.3.1 Features

Gear ratios: $i = 1:1$ to $4:1$
 Maximum output torque: 16 Nm
 2 gearbox sizes with edge lengths of 035 to 045 mm
 Low-backlash construction < 8 angular minutes possible
 Housing made of aluminium



035 – 045 mm

5.3.2 Models

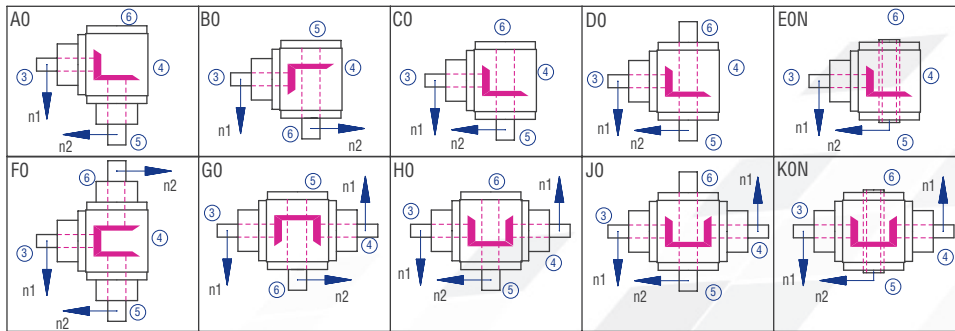

Figure 5.3.2-1; Models

5.3.3 Gearbox sides

The example shows the Model C0

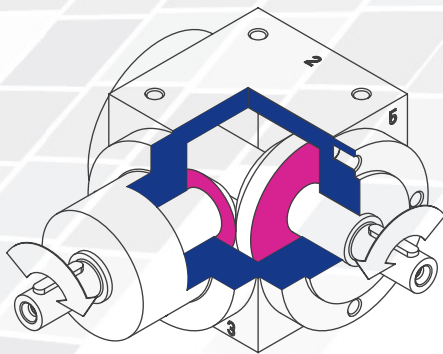

Figure 5.3.3-2; Gearbox sides

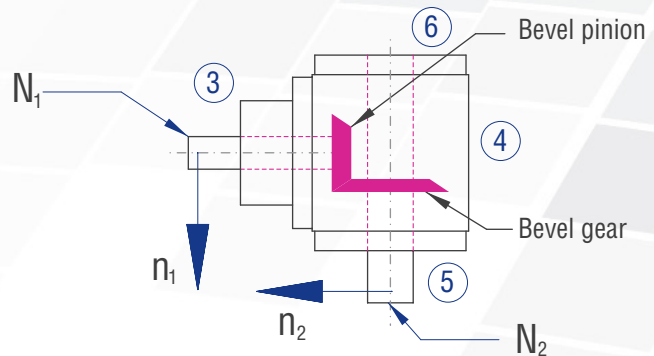

Figure 5.3.3-1; Shaft designations

5.3.4 Order code

The order code reflects the customer specifications. Example:

Type	Size	Gear ratio	Model	Fixing side	Installation position	Speed n_2	Design
L	045	1:1	C0-	1.	1-	1500	/0000
Description	Housing edge length; Table 5.3.5-1	Table 5.3.5-1	Figure 5.3.2-1; Models	Gearbox side on which fixing is made; Table 5.2.2-1; Figure 4.3.1-1; Gearbox sides	Gearbox side directed downwards; Figure 4.3.1-1; Gearbox sides	slowly rotating shaft; Table 5.3.5-1	Standard

Table 5-4

5.3.5 Overview of performance data

Size	n ₁ [rpm]	1:1		2:1			3:1			4:1			
		n ₂ [rpm]	P _{1N} [kW]	T _{2N} [Nm]	n ₂ [rpm]	P _{1N} [kW]	T _{2N} [Nm]	n ₂ [rpm]	P _{1N} [kW]	T _{2N} [Nm]	n ₂ [rpm]	P _{1N} [kW]	T _{2N} [Nm]
035	3000	3000	0.66	2.0									
	2400	2400	0.63	2.4									
	1500	1500	0.50	3.0									
	1000	1000	0.39	3.5									
	750	750	0.30	3.6									
	500	500	0.22	4.0									
	250	250	0.12	4.5									
	50	50	0.03	4.5									
045	3000	3000	1.32	4.0	1500	0.74	4.5	1000	0.33	3.0	750	0.29	3.5
	2400	2400	1.19	4.5	1200	0.63	4.8	800	0.30	3.4	600	0.24	3.6
	1500	1500	0.99	6.0	750	0.41	5.0	500	0.19	3.5	375	0.16	3.8
	1000	1000	0.77	7.0	500	0.30	5.5	333	0.15	4.0	250	0.11	4.0
	750	750	0.60	7.3	375	0.24	5.7	250	0.12	4.2	188	0.09	4.2
	500	500	0.44	8.0	250	0.17	6.0	167	0.08	4.5	125	0.06	4.3
	250	250	0.25	9.0	125	0.09	6.5	83	0.05	5.0	63	0.03	4.5
	50	50	0.05	9.0	25	0.02	7.0	17	0.01	5.5	13	0.01	4.5

Table 5.3.5-1

5.3.6 Type L 035 – Miniature bevel gearboxes



Characteristics

Characteristic	Standard	Option
Toothing	Bevel gear set, spiral-toothed	See chapter 5.2
Gear ratio	1:1	
Housing / Flanges	Aluminium	See chapter 5.2
Threaded mounting hole	On all housing surfaces without flange and on all flanges.	See chapter 5.2.2
Shaft	Material 1 C45, shaft ends greased Fit with ISO 6 tolerance with parallel keyway: according to DIN 6885 Sheet 1	See chapter 4.6.2
Hollow shaft	Material 1 C45, shafts greased Fit with ISO 7 tolerance with parallel keyway according to DIN 6885 Sheet 1	See chapter 4.6.3
Radial shaft seal ring	NBR, form A	See chapter 4.8
Ambient temperature	- 10°C to + 90°C. The values of the performance tables are valid for +20°C	See chapter 4.9.3
Circumferential backlash	< 30 arcmin	See chapter 5.2.9
Protection class	IP 54	See chapter 4.5
Corrosion protection	-	See chapter 5.2.10
Bearing life L10h	more than 15,000h	See chapter 4.9.1
Oil change intervals	Not required	See chapter 5.2.7
Lubricant	Synthetic lubricants	See chapter 5.2.7

Performance data

n_1 [rpm]	1:1			2:1			3:1			4:1			
	n_2 [rpm]	P_{1N} [kW]	T_{2N} [Nm]	n_2 [rpm]	P_{1N} [kW]	T_{2N} [Nm]	n_2 [rpm]	P_{1N} [kW]	T_{2N} [Nm]	n_2 [rpm]	P_{1N} [kW]	T_{2N} [Nm]	
3000	3000	0.66	2.0										
2400	2400	0.63	2.4										
1500	1500	0.50	3.0										
1000	1000	0.39	3.5										
750	750	0.30	3.6										
500	500	0.22	4.0										
250	250	0.12	4.5										
50	50	0.03	4.5										
P_{1Nt} [kW]		0.35											
T_{2max} [Nm]		8.00											

Permissible radial force F_{r1} and axial force F_{a1} on shaft N_1

n_1 [rpm]	3000		1000		500		250		100		50	
T_2 [Nm]	F_r [N]	F_a [N]	F_r [N]	F_a [N]	F_r [N]	F_a [N]	F_r [N]	F_a [N]	F_r [N]	F_a [N]	F_r [N]	F_a [N]
	10	5	20	10	30	15	50	25	70	35	90	45

Permissible radial force F_{r2} and axial force F_{a2} on shaft N_2

n_1 [rpm]	3000		1000		500		250		100		50	
T_2 [Nm]	F_r [N]	F_a [N]	F_r [N]	F_a [N]	F_r [N]	F_a [N]	F_r [N]	F_a [N]	F_r [N]	F_a [N]	F_r [N]	F_a [N]
	30	15	50	25	80	40	120	60	150	75	220	110

Inertia moments/mass

Model	Inertia moment [kgcm ²]			
	1:1	2:1	3:1	4:1
A0	0.0204			
B0	0.0219			
C0	0.0219			
D0	0.0224			
E0N	0.0149			
F0	0.0306			
G0	0.0321			
H0	0.0321			
J0	0.0326			
K0N	0.0251			

Mass ca. [g]
230
225
225
230
210
290
285
285
290
270

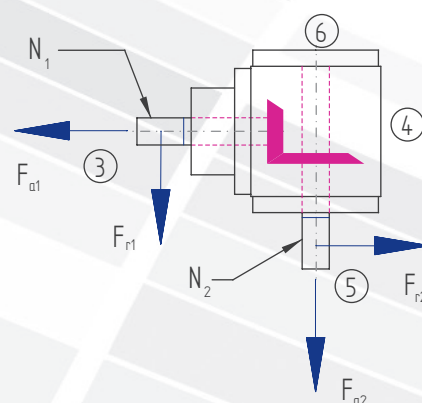

The mass of the gearbox may deviate depending on the gear ratio.

5.3.6 Type L 035 – Miniature bevel gearboxes

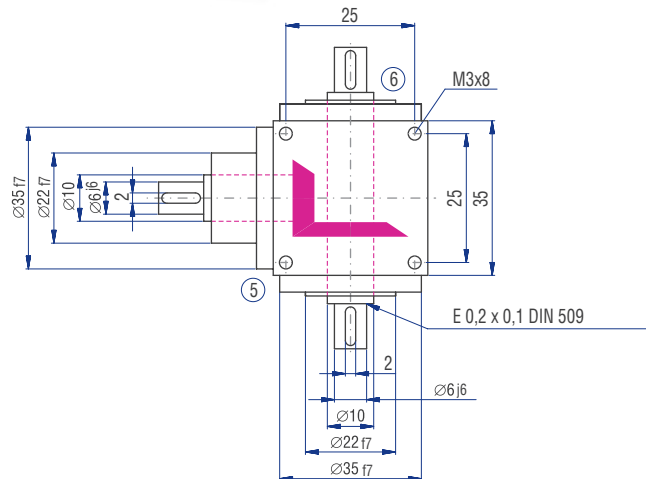
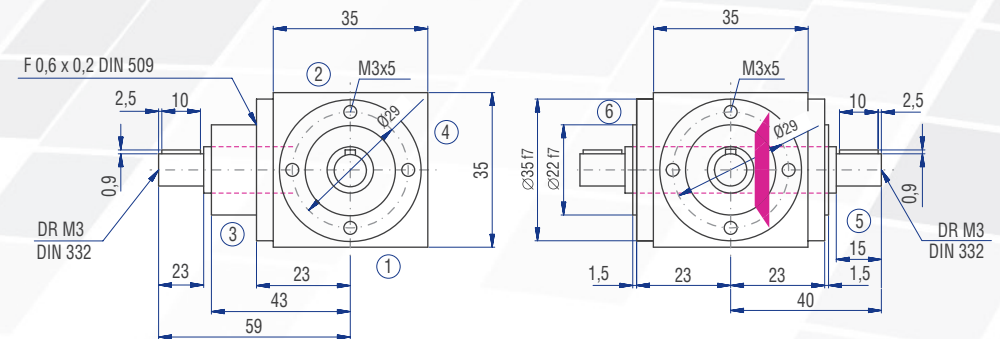
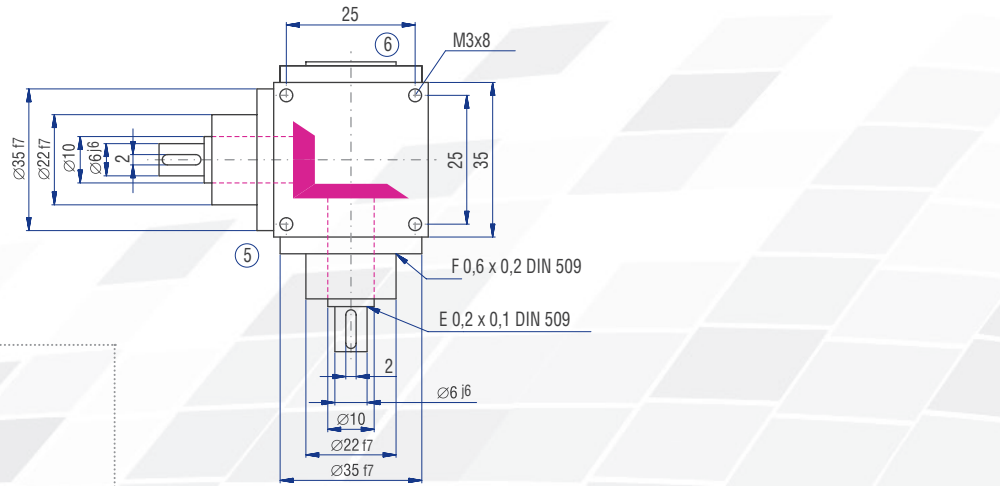
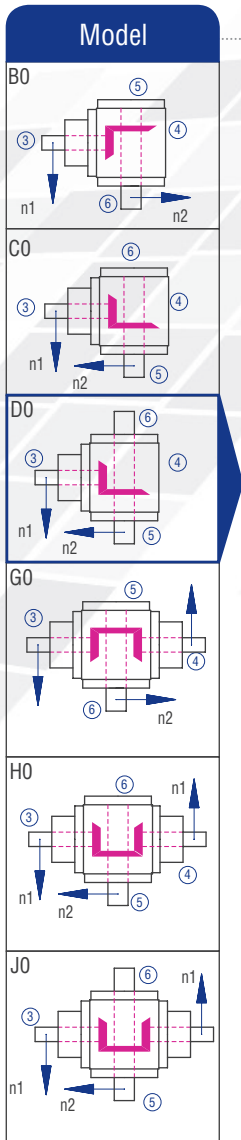
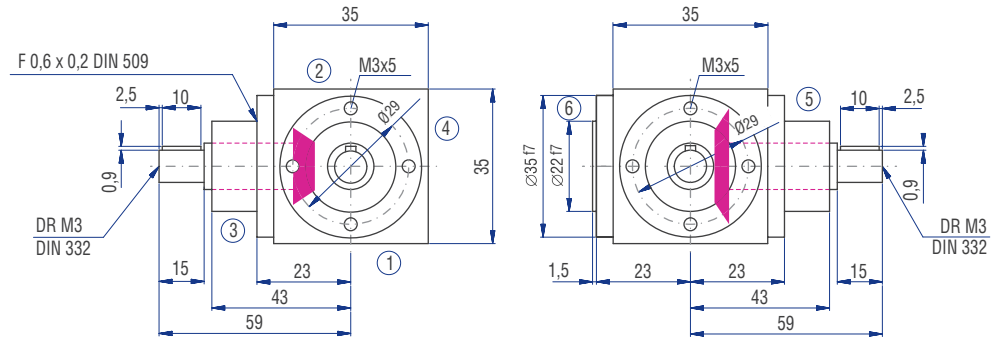
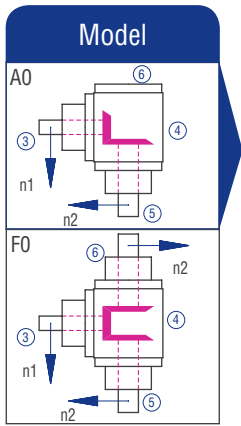

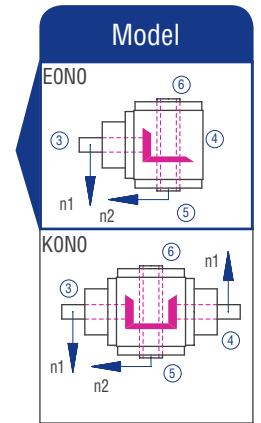
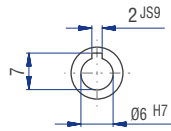
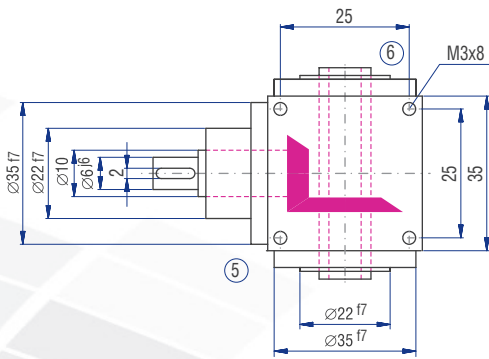
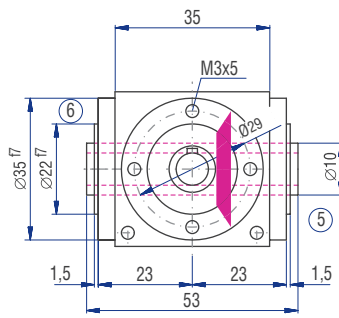
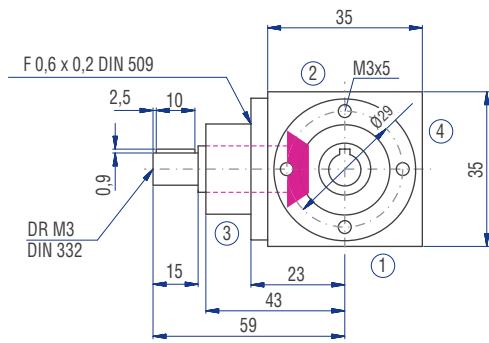

Miniature
bevel gearboxes

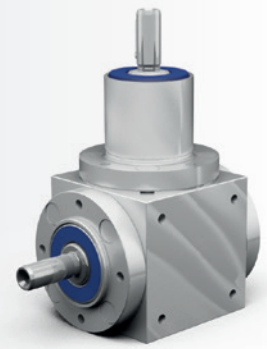

Characteristics

Characteristic	Standard	Option
Toothing	Bevel gear set, spiral-toothed	See chapter 5.2
Gear ratio	1:1 to 4:1	
Housing / Flanges	Aluminium	See chapter 5.2
Threaded mounting hole	On all housing surfaces without flange and on all flanges.	See chapter 5.2.2
Shaft	Material 1 C45, shaft ends greased Fit with ISO 6 tolerance with parallel keyway: according to DIN 6885 Sheet 1	See chapter 4.6.2
Hollow shaft	Material 1 C45, shafts greased Fit with ISO 7 tolerance with parallel keyway according to DIN 6885 Sheet 1	See chapter 4.6.3
Radial shaft seal ring	NBR, form A	See chapter 4.8
Ambient temperature	- 10°C to + 90°C. The values of the performance tables are valid for +20°C	See chapter 4.9.3
Circumferential backlash	< 30 arcmin	See chapter 5.2.9
Protection class	IP 54	See chapter 4.5
Corrosion protection	-	See chapter 5.2.10
Bearing life L10h	more than 15,000h	See chapter 4.9.1
Oil change intervals	Not required	See chapter 5.2.7
Lubricant	Synthetic lubricants	See chapter 5.2.7

Performance data

n_1 [rpm]	1:1			2:1			3:1			4:1		
	n_2 [rpm]	P_{1N} [kW]	T_{2N} [Nm]	n_2 [rpm]	P_{1N} [kW]	T_{2N} [Nm]	n_2 [rpm]	P_{1N} [kW]	T_{2N} [Nm]	n_2 [rpm]	P_{1N} [kW]	T_{2N} [Nm]
3000	3000	1.32	4.0	1500	0.74	4.5	1000	0.33	3.0	750	0.29	3.5
2400	2400	1.19	4.5	1200	0.63	4.8	800	0.30	3.4	600	0.24	3.6
1500	1500	0.99	6.0	750	0.41	5.0	500	0.19	3.5	375	0.16	3.8
1000	1000	0.77	7.0	500	0.30	5.5	333	0.15	4.0	250	0.11	4.0
750	750	0.60	7.3	375	0.24	5.7	250	0.12	4.2	188	0.09	4.2
500	500	0.44	8.0	250	0.17	6.0	167	0.08	4.5	125	0.06	4.3
250	250	0.25	9.0	125	0.09	6.5	83	0.05	5.0	63	0.03	4.5
50	50	0.05	9.0	25	0.02	7.0	17	0.01	5.5	13	0.01	4.5
P_{1Nt} [kW]	0.60			0.60			0.60			0.60		
T_{2max} [Nm]	16.00			12.00			10.00			8.00		

Permissible radial force F_{r1} and axial force F_{a1} on shaft N_1

n_1 [rpm]	3000		1000		500		250		100		50	
T_2 [Nm]	F_r [N]	F_a [N]	F_r [N]	F_a [N]	F_r [N]	F_a [N]	F_r [N]	F_a [N]	F_r [N]	F_a [N]	F_r [N]	F_a [N]
	80	40	100	50	120	60	150	75	200	100	250	125

Permissible radial force F_{r2} and axial force F_{a2} on shaft N_2

n_1 [rpm]	3000		1000		500		250		100		50	
T_2 [Nm]	F_r [N]	F_a [N]	F_r [N]	F_a [N]	F_r [N]	F_a [N]	F_r [N]	F_a [N]	F_r [N]	F_a [N]	F_r [N]	F_a [N]
	100	50	170	85	220	110	300	150	400	200	500	250

Inertia moments/mass

Model	Inertia moment [kgcm ²]			
	1:1	2:1	3:1	4:1
A0	0.0630	0.0340	0.0310	0.0300
B0	0.1380	0.0550	0.0390	0.0350
C0	0.1380	0.0550	0.0390	0.0350
D0	0.1400	0.0550	0.0390	0.0350
E0N	0.1310	0.0530	0.0380	0.0350
F0	0.0630	0.0340	0.0310	0.0300
G0	0.2010	0.0870	0.0700	0.0660
H0	0.2010	0.0870	0.0700	0.0660
J0	0.2030	0.0880	0.0700	0.0660
K0N	0.1940	0.0860	0.0690	0.0650

Mass ca. [g]
510
500
500
530
460
700
660
660
690
620

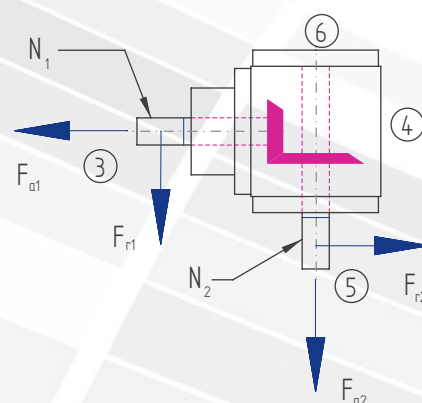

The mass of the gearbox may deviate depending on the gear ratio.

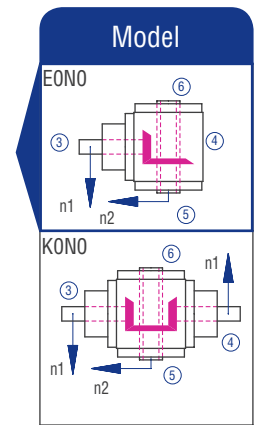
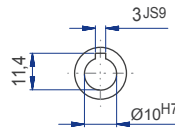
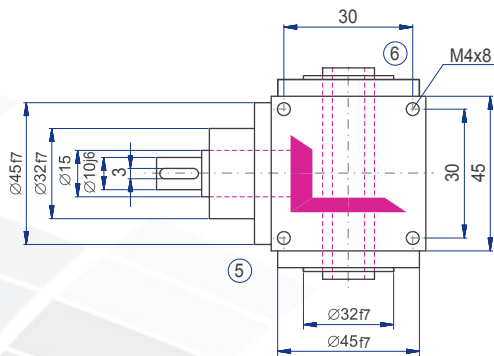
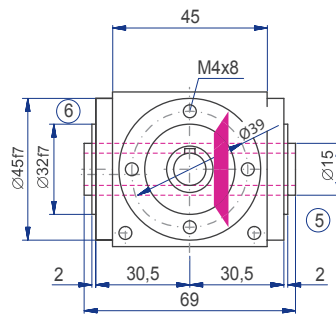
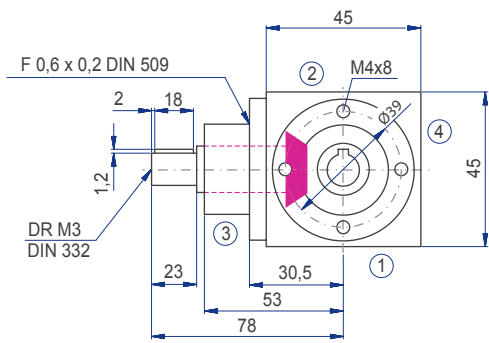

Miniature
bevel gearboxes