

**Abstract from ISO 4347**

Chains may be assembled with chain parts according to ISO 606. Therefore the actual pitch may deviate from the nominal pitch. The permissible length deviation refers to the length specification of the manufacturer and is  $\pm 0,25\%$  under the measuring force.

Chain			Nominal pitch		Lacing	Width over		Pin $\varnothing$ $d_2$ max.	Plate		Effective length over 100 x pitch* mm	Bearing area $f \approx$ cm <sup>2</sup>	Breaking load ISO $F_B$ min. kN	Weight $q \approx$ kg/m
No.	Ind.	ISO No.	p			Pins	Plates		thickness s	height $g_1$ max.				
			mm	inch	$l_1$ max. mm	B max. mm								
F 122		LL 0822	12,700	1/2	2 x 2	9,0	6,4	4,45	1,55	10,7	1260	0,138	18,0	0,39
F 124		LL 0844	12,700	1/2	4 x 4	15,2	12,8	4,45	1,55	10,7	1260	0,276	36,0	0,74
F 126		LL 0866	12,700	1/2	6 x 6	21,4	19,0	4,45	1,55	10,7	1260	0,414	54,0	1,10
F 152		LL 1022	15,875	5/8	2 x 2	10,0	7,2	5,08	1,65	12,6	1580	0,175	26,0	0,50
F 154		LL 1044	15,875	5/8	4 x 4	17,1	14,5	5,08	1,65	12,6	1580	0,349	50,0	0,96
F 156		LL 1066	15,875	5/8	6 x 6	24,1	21,5	5,08	1,65	12,6	1580	0,524	78,0	1,39
F 192		LL 1222	19,050	3/4	2 x 2	10,7	7,8	5,72	1,83	14,7	1892	0,209	33,0	0,59
F 194		LL 1244	19,050	3/4	4 x 4	18,1	15,2	5,72	1,83	14,7	1892	0,419	66,0	1,15
F 196		LL 1266	19,050	3/4	6 x 6	25,4	22,6	5,72	1,83	14,7	1892	0,628	99,0	1,70
F 194 S		-	19,050	3/4	4 x 4	21,0	18,6	5,98	2,25	14,7	1905	0,515	76,5	1,40
F 196 S		-	19,050	3/4	6 x 6	31,5	27,8	5,98	2,25	14,7	1905	0,772	115,0	2,10
F 252		LL 1622	25,400	1	2 x 2	17,2	12,8	8,28	3,00	21,1	2532	0,500	70,0	1,56
F 254		LL 1644	25,400	1	4 x 4	29,3	25,6	8,28	3,00	21,1	2532	0,994	140,0	3,04
F 256		LL 1666	25,400	1	6 x 6	41,3	37,5	8,28	3,00	21,1	2532	1,490	210,0	4,53
F 312		LL 2022	31,750	1 1/4	2 x 2	20,3	16,0	10,19	3,75	25,4	3170	0,750	105,0	2,01
F 314		LL 2044	31,750	1 1/4	4 x 4	36,5	32,0	10,19	3,75	25,4	3170	1,500	210,0	3,93
F 316		LL 2066	31,750	1 1/4	6 x 6	51,5	48,0	10,19	3,75	25,4	3170	2,250	315,0	5,86
F 382		LL 2422	38,100	1 1/2	2 x 2	26,5	21,0	14,63	5,00	33,4	3797	1,460	175,0	4,18
F 384		LL 2444	38,100	1 1/2	4 x 4	46,5	42,0	14,63	5,00	33,4	3797	2,930	350,0	8,48
F 386		LL 2466	38,100	1 1/2	6 x 6	67,5	62,0	14,63	5,00	33,4	3797	4,390	525,0	12,20
F 502		LL 3222	50,800	2	2 x 2	30,5	25,0	17,81	6,00	43,0	5070	2,140	265,0	6,73
F 504		LL 3244	50,800	2	4 x 4	54,5	50,0	17,81	6,00	43,0	5070	4,280	530,0	13,10
F 506		LL 3266	50,800	2	6 x 6	80,5	74,0	17,81	6,00	43,0	5070	6,420	800,0	19,50
F 508		LL 3288	50,800	2	8 x 8	105,5	99,0	17,81	6,00	43,0	5070	8,560	1050,0	25,80
F 501		LL 3110	50,800	2	10 x 10	130,0	123,0	17,81	6,00	43,0	5070	10,850	1330,0	31,56
F 632		LL 4022	63,500	2 1/2	2 x 2	44,7	33,2	22,89	8,00	52,0	6335	3,525	422,0	10,51
F 634		LL 4044	63,500	2 1/2	4 x 4	77,9	65,6	22,89	8,00	52,0	6335	7,050	845,0	20,29
F 636		LL 4066	63,500	2 1/2	6 x 6	111,1	98,0	22,89	8,00	52,0	6335	10,575	1270,0	29,74
F 638		LL 4088	63,500	2 1/2	8 x 8	136,0	130,4	22,89	8,00	52,0	6335	14,100	1690,0	39,30

\* Chain length tolerance  $\pm 0,25\%$  of uncoiled chain under measuring force.

For ordering examples, end links and connecting pins see page 70.

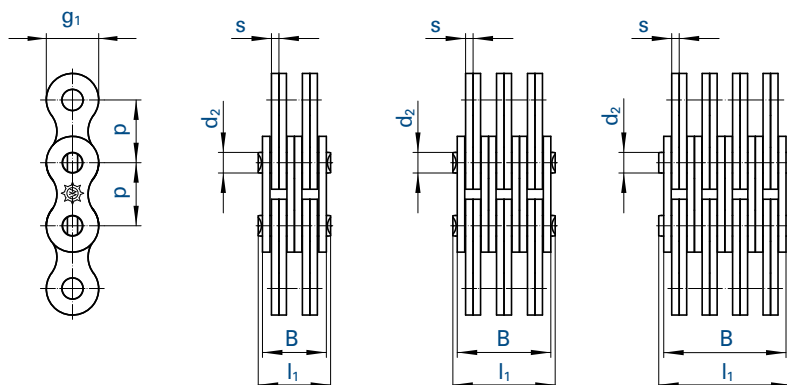

Chain		Nominal pitch		Lacing	Width over		Pin Ø  d <sub>2</sub> max.	Plate		Effective length over 100 x pitch*	Bearing area  f ≈	Breaking load  F <sub>B</sub> min.	Weight  q ≈
⚙		p			Pins  l <sub>1</sub> max.	Plates  B max.		thickness  s	height  g <sub>1</sub> max.				
No.	Ind.	mm	inch		mm	mm	mm	mm	mm	mm	cm <sup>2</sup>	kN	kg/m
FU 154		15,875	5/8	4 x 4	17,1	14,5	5,08	1,65	14,4	1596	0,350	52,0	1,2
FU 156		15,875	5/8	6 x 6	24,1	21,5	5,08	1,65	14,4	1596	0,524	78,0	1,8
FU 158		15,875	5/8	8 x 8	30,9	28,0	5,08	1,65	14,4	1596	0,699	102,0	2,3
FU 156 S		15,875	5/8	6 x 6	27,5	25,0	5,08	2,05	14,7	1596	0,625	83,5	2,1
FU 194		19,050	3/4	4 x 4	18,1	15,2	5,72	1,83	16,1	1907	0,419	66,0	1,4
FU 196		19,050	3/4	6 x 6	25,4	22,6	5,72	1,83	16,1	1907	0,628	99,0	2,3
FU 196 S		19,050	3/4	6 x 6	31,7	28,8	6,50	2,35	18,1	1907	0,917	130,0	2,9
FU 254		25,400	1	4 x 4	29,3	25,6	8,28	3,00	23,0	2550	0,994	140,0	3,5
FU 256		25,400	1	6 x 6	41,3	37,5	8,28	3,00	23,0	2550	1,490	210,0	5,0
FU 258		25,400	1	8 x 8	53,1	49,0	8,28	3,00	23,0	2550	1,987	280,0	6,8

\* Chain length tolerance ± 0,25 % of uncoiled chain under measuring force.

For ordering examples, end links and connecting pins see page 70.

For information on the selection of chain sizes see pages 116/117.

## Leaf chains heavy duty design U according to works-standard

With chains of this type all plates are mounted with a sliding fit and are also secured with laterally attached riveted washers. This design guarantees an even load distribution and reduces the bending load of the pin. These chains have been designed to transport heavy loads under harsh conditions. They are particularly suitable for such applications due to their high fatigue strength.

Chain		Nominal pitch		Lacing	Width over		Pin Ø  d <sub>2</sub> max.	Plate		Effective length over 100 x pitch*	Bearing area  f ≈	Breaking load  F <sub>B</sub> min.	Weight  q ≈
⚙		p			Pins  l <sub>1</sub> max.	Plates  B max.		thickness  s	height  g <sub>1</sub> max.				
No.	Ind.	mm	inch		mm	mm	mm	mm	mm	mm	cm <sup>2</sup>	kN	kg/m
F 384 U		38,1	1 1/2	4 x 4	53,2	42,0	14,63	5,00	33,4	3802	2,926	354,0	9,1
F 386 U		38,1	1 1/2	6 x 6	75,2	62,0	14,63	5,00	33,4	3802	4,389	540,0	12,5
F 388 U		38,1	1 1/2	8 x 8	94,2	83,0	14,63	5,00	33,4	3802	5,852	700,0	16,5
F 504 U		50,8	2	4 x 4	60,2	50,0	17,81	6,00	43,0	5073	4,274	530,0	13,5
F 506 U		50,8	2	6 x 6	87,2	74,0	17,81	6,00	43,0	5073	6,412	800,0	20,0
F 508 U		50,8	2	8 x 8	111,2	99,0	17,81	6,00	43,0	5073	8,549	1050,0	26,5
F 501 U		50,8	2	10 x 10	135,0	123,0	17,81	6,00	43,0	5073	10,686	1330,0	33,1
F 634 U		63,5	2 1/2	4 x 4	81,2	70,0	22,89	8,00	52,0	6340	5,494	845,0	19,4
F 636 U		63,5	2 1/2	6 x 6	112,2	101,0	22,89	8,00	52,0	6340	10,990	1270,0	29,1
F 638 U		63,5	2 1/2	8 x 8	146,0	135,0	22,89	8,00	52,0	6340	14,650	1690,0	38,8

\* Chain length tolerance ± 0,25 % of uncoiled chain under measuring force.

For ordering examples, end links and connecting pins see page 70.

For information on the selection of chain sizes see pages 116/117.



### Inner end link

4 x 4

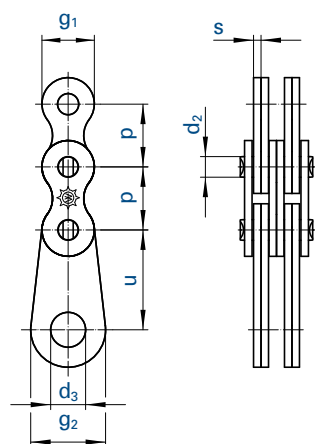

### Outer end link

4 x 4

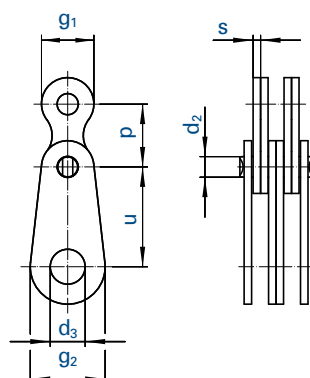

### Connecting pin

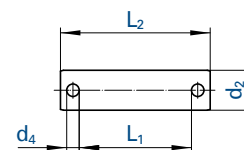

Leaf chains are only supplied with end links on customers' request. The design with either outer or inner end link must be stated in the order.

#### Design of chain ends:

Only the normal links are counted

- A Both sides with inner end links (uneven number of links)
- B Both sides with outer end links (uneven number of links)
- C One side with inner end link, other side with outer end link (even number of links)
- D One side with inner end link, other side with inner link (even number of links)
- E One side with outer end link, other side with outer link (even number of links)
- F One side with inner end link, other side with outer link (uneven number of links)
- G One side with outer end link, other side with inner link (uneven number of links)
- H Both sides with inner links (uneven number of links)
- I Both sides with outer links (uneven number of links)
- K One side with inner link, other side with outer link (even number of links)

Designation of a leaf chain design A with 25,4 mm pitch, combination 4 x 4, 45 normal links and end links on both sides:  
F 254 A x 45

Chain		Nominal pitch		End plates								Connecting pins								
				u	d <sub>2</sub>	d <sub>3</sub>	g <sub>1</sub>	g <sub>2</sub>	s	d <sub>2</sub>	d <sub>4</sub>	2 x 2		4 x 4		6 x 6		8 x 8		
No.	Ind.	mm	inch	mm	mm	mm	mm	mm	mm	mm	mm	mm	mm	mm	mm	mm	mm	mm	mm	mm
F 12		12,700	½	30	4,45	10,0	10,5	20	1,55	4,45	1,6	6,8	13,0	13,6	19,8	20,4	26,6	-	-	-
F 15		15,875	⅝	30	5,08	10,0	12,5	20	1,70	5,08	1,6	7,4	13,6	14,8	21,0	21,8	28,0	-	-	-
F 19		19,050	¾	30	5,72	10,0	14,5	20	1,80	5,72	1,6	8,0	14,2	15,4	21,6	22,9	29,1	-	-	-
F 25		25,400	1	45	8,28	16,0	21,0	35	3,00	8,28	3,4	13,0	23,8	25,9	36,7	38,0	48,8	51,0	61,8	61,8
F 31		31,750	1 ¼	45	10,19	16,0	24,5	35	3,80	10,19	3,4	16,4	27,2	32,4	43,2	48,5	59,3	64,8	75,6	75,6
F 38		38,100	1 ½	60	14,63	26,0	33,0	50	5,00	14,63	4,2	21,3	33,7	42,4	54,8	63,5	75,9	84,8	97,2	97,2
F 50		50,800	2	70	17,81	36,0	43,0	70	6,00	17,81	4,2	25,5	37,9	50,5	62,9	75,5	87,9	100,7	113,0	113,0
F 63		63,500	2 ½	90	22,89	45,0	52,0	80	8,00	22,89	5,2	-	-	66,4	86,8	99,6	120,0	132,8	153,2	153,2
FU 12		12,700	½	30	4,45	10,0	11,5	20	1,55	4,45	1,6	-	-	13,6	19,8	20,4	26,6	-	-	-
FU 15		15,875	⅝	30	5,08	10,0	14,5	20	1,70	5,08	1,6	-	-	14,8	21,0	21,8	28,0	28,3	34,5	34,5
FU 15 S		15,875	⅝	20	5,08	8,3	14,7	18	2,00	5,08	1,6	-	-	-	30,9	37,5	-	-	-	-
FU 19		19,050	¾	30	5,72	10,0	15,4	20	1,80	5,72	1,6	-	-	15,4	21,6	22,9	29,1	-	-	-
FU 19 S		19,050	¾	25	6,50	10,3	18,0	20	2,30	6,50	1,6	-	-	19,6	25,8	29,3	35,5	-	-	-
FU 25		25,400	1	45	8,28	16,0	21,0	35	3,00	8,28	3,4	-	-	25,9	36,7	38,0	48,8	51,0	61,8	61,8
F 38 U		38,100	1 ½	60	14,63	26,0	33,0	50	5,00	14,63	4,2	-	-	48,4	61,0	70,0	82,4	90,8	103,2	103,2
F 50 U		50,800	2	70	17,81	36,0	43,0	70	6,00	17,81	4,2	-	-	56,5	68,9	81,5	93,9	106,8	119,2	119,2
F 63 U		63,500	2 ½	90	22,89	45,0	52,0	80	8,00	22,89	5,2	-	-	72,4	92,8	105,6	126,0	138,8	159,2	159,2

Other dimensions on request.

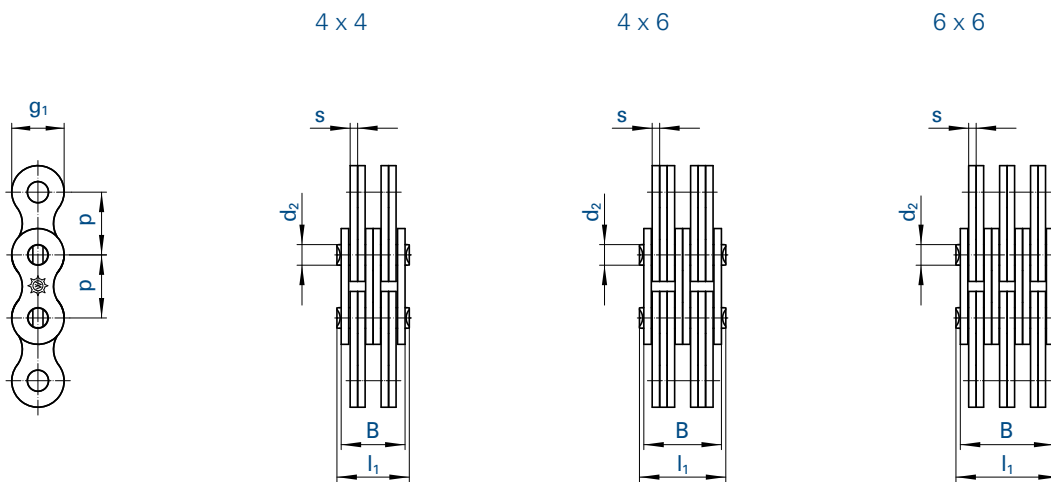

Chain		Nominal pitch	Lacing	Width over		Pin $\varnothing$	Plate		Effective length over 100 x pitch*	Bearing area	Breaking load ISO	Weight		
No.	Ind.			Pins	Plates		thickness	height						
ISO		p		$l_1$ max.	B max.	$d_2$ max.	s	$g_1$ max.	f $\approx$	$F_B$ min.	q $\approx$			
No.	Ind.	No.	mm	inch	mm	mm	mm	mm	mm	mm	cm <sup>2</sup>	kN	kg/m	
BL 544		LH 1044	15,875	5/8	4 x 4	22,7	20,0	5,95	2,46	15,1	1592	0,570	66,8	1,86
BL 546		LH 1046	15,875	5/8	4 x 6	27,7	24,8	5,95	2,46	15,1	1592	0,860	66,8	2,32
BL 566		LH 1066	15,875	5/8	6 x 6	32,1	29,7	5,95	2,46	15,1	1592	0,860	100,2	2,77
BL 844		LH 1644	25,400	1	4 x 4	37,9	33,2	9,53	4,06	24,0	2544	1,490	169,0	4,72
BL 846		LH 1646	25,400	1	4 x 6	46,1	41,4	9,53	4,06	24,0	2544	2,230	169,0	5,88
BL 866		LH 1666	25,400	1	6 x 6	54,4	49,4	9,53	4,06	24,0	2544	2,230	253,6	7,04

\* Chain length tolerance  $\pm 0,25$  % of uncoiled chain under measuring force.

For a pre-selection of leaf chains see page 116/117.