

DATASHEET: CONVEYOR CHAIN

Protorque conveyor chains are a great solution when you need to transport unit loads and bulk goods. The chains are suitable for a variety of common conveying purposes and can be used in industries like food and beverage, agriculture, and wood industries.

Properties



Temperature operating range between -10°C to $+80^{\circ}\text{C}$ with standard lubrication.



Standard lubrication can be used on all chains used for common types of applications, directly out of the box.



Carbon steel side plates gives excellent wear resistance for increased life and decreased maintenance.



Protorque chains are ISO 1977 - DIN 8165 - DIN 8167 and meet RoHS and REACH requirements.

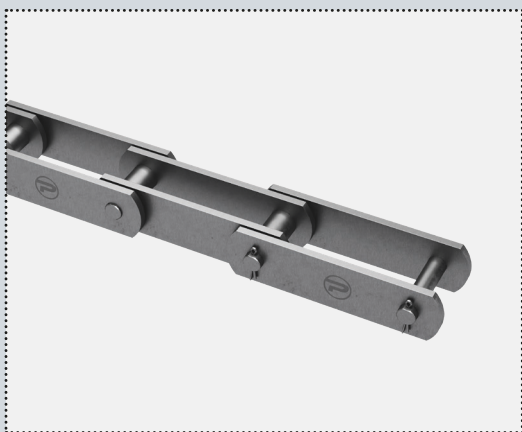

> Metric Standard Chain

The chains are suitable for larger bulk handling and demanding applications. A cost-effective and reliable chain constructed according to established standard.

You will find a wide selection of the most common M and FV conveyor chains available from stock.



TECHNICAL INFORMATION

> Metric Standard Chain

M-Chain										
ISO 1977	Size	Pitch (MM)	Max roller dia d1 (mm)	Min. inner width b1 (mm)	Max pin dia d2 (mm)	Max plate height (mm)	Innerplate thickness (mm)	Outerplate thickness (mm)	Max width over pins (mm)	Min break load (mm)
M80A80P	M80	80	18	28	12	35	5	5	54.5	80
M80A125P	M80	125	18	28	12	35	5	5	54.5	80
M80A100P	M80	100	18	28	12	35	5	5	54.5	80
M56A80P	M56	80	15	24	10	30	4	4	45	56
M56A63P	M56	63	15	24	10	30	4	4	45	56
M56A125P	M56	125	15	24	10	30	4	4	45	56
M56A100P	M56	100	15	24	10	30	4	4	45	56
M224A200P	M224	200	30	43	21	60	8	8	84	224
M224A160P	M224	160	30	43	21	60	8	8	84	224
M224A125P	M224	125	30	43	21	60	8	8	84	224
M160A160P	M160	160	25	37	18	50	7	7	72	160
M160A125P	M160	125	25	37	18	50	7	7	72	160
M160A100P	M160	100	25	37	18	50	7	7	72	160
M112A80P	M112	80	21	32	15	40	6	6	63	112
M112A160P	M112	160	21	32	15	40	6	6	63	112
M112A125P	M112	125	21	32	15	40	6	6	63	112
M112A100P	M112	100	21	32	15	40	6	6	63	112

FV-Chain										
ISO 1977	Size	PITCH (MM)	Max roller dia d1 (mm)	Min. inner width b1 (mm)	Max pin dia d2 (mm)	Max plate height (mm)	Innerplate thickness (mm)	Outerplate thickness (mm)	Max width over pins (mm)	Min break load (mm)
FV63A100P	FV63	100	12	22	18	30	4	4	45	64
FV9063P	FV90	63	14	25	20	35	5	5	53	100
FV90A125P	FV90	125	14	25	20	35	5	5	53	100
FV90A100P	FV91	100	14	25	20	35	5	5	53	100
FV112A125P	FV112	125	16	30	22	40	6	6	62	120
FV112A100P	FV113	100	16	30	22	40	6	6	62	120
FV140A160P	FV140	160	18	35	26	45	6	6	67	145
FV140A125P	FV141	125	18	35	26	45	6	6	67	145
FV180A160P	FV180	160	20	45	30	50	8	8	86	190
FV180A100P	FV180	100	20	45	30	50	8	8	86	190



YOUR AUTHORISED DISTRIBUTOR IS:

JENS S TRANSMISSIONER A/S
Hørskættøen 7, DK-2630 Taastrup
Denmark

Telephone: +457 0138 333
Email: info@jens-s.dk
Website: www.jens-s.dk/transmissioner