

MOTODOR



MOTOVARIO®
HEART OF MOTION

a TECO Group company

MOTODOOR

The new **MOTODOOR** solution is available: a dedicated geared motor for industrial and civil doors.

MOTODOOR is safe, efficient and reliable, able to grant advanced solutions to the most demanding market.

MOTODOOR is the perfect proposal to OEMs that would like to integrate their own control systems.



POWER SUPPLY UNIT MAIN FEATURES:

- Worm gearbox
- Electric motor
- Security system

VERSIONS

GEARBOX	FEATURES
<p>MDA WORM GEARBOX WITH ENCODER SHAFT</p>	<p>Standard solution for the normal working cycle</p>
<p>MDB WORM GEARBOX WITH ENCODER SHAFT AND PARACHUTE SYSTEM</p>	 <p>Certified solution including safety system device to block the door in case of failure</p>
<p>MDC WORM GEARBOX WITH ENCODER SHAFT AND RELEASE LEVER</p>	<p>Advanced solution including a dedicated device for the manual handling of the door</p>

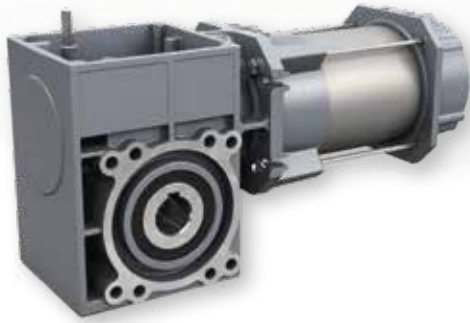

Three Phase Motor

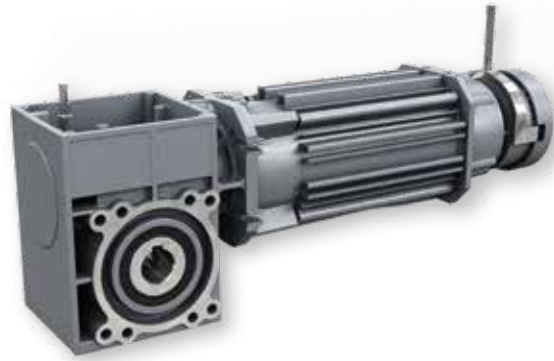

Three Phase Brake Motor

SIZE	TYPE	i	TS TSB	TMD TBMD	TS TBS	TMD TBMD	TS TBS	TS TBS
			200x14	200x14	200x14	200x14	200x14	200x14
			0,37 kW 6 poles	0,55 kW 4 poles	0,75 kW 4 poles	1,00 kW 4 poles	1,10 kW 4 poles	1,50 kW 4 poles
050	MDA	10	•	•	•	•	•	•
		15	•	•	•	•	•	
		20	•	•	•	•	•	
		35	•	•	•	•	•	
		60	•	•	•			
		80	•	•				
	MDB	10	•	•	•	•	•	•
		15	•	•	•	•	•	•
		20	•	•	•	•	•	•
		80	•	•				
	MDC	60	•	•	•			
		80	•	•				

(•) Feasible combination with duty S3 40%

PERFORMANCES

- Output torque up to 140 Nm
- Encoder shaft ratio $Lg_i = 15/30$
- Ratios up to 80
- Motor power up to 1,5 kW

AVAILABLE ON REQUEST

- Ratios 7,5/30/40/50/100
- Absolute encoder

DIMENSIONAL

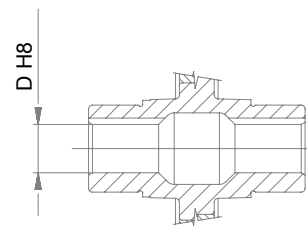
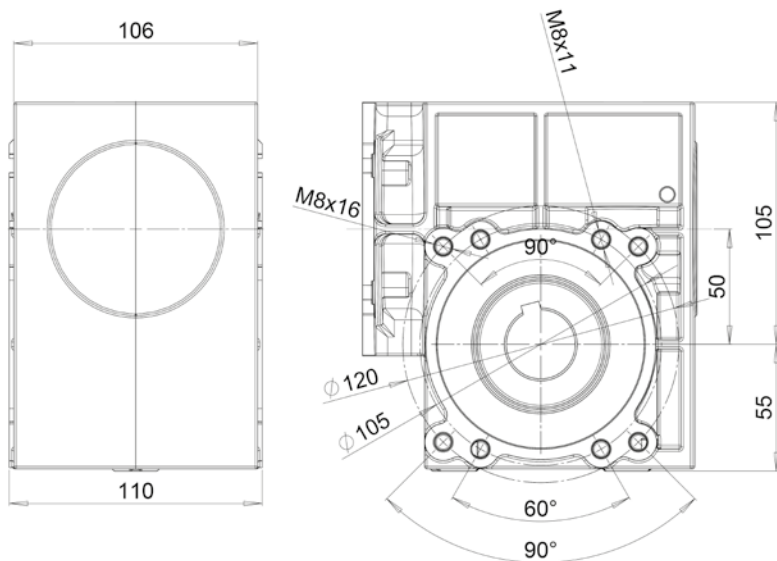

Output shaft diameter [mm] D H8
25
25,44
30
31,75

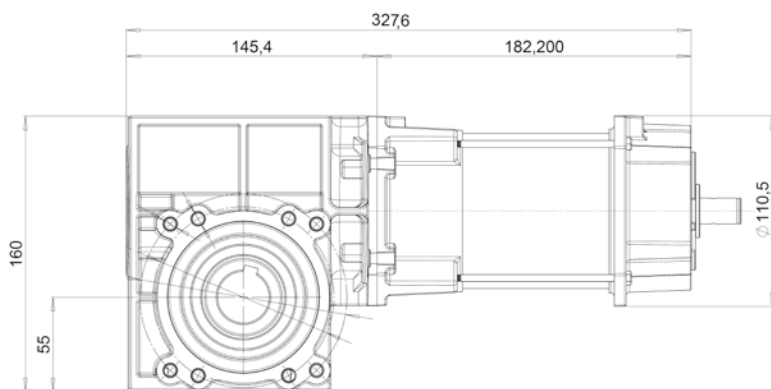

THREE PHASE
MOTOR

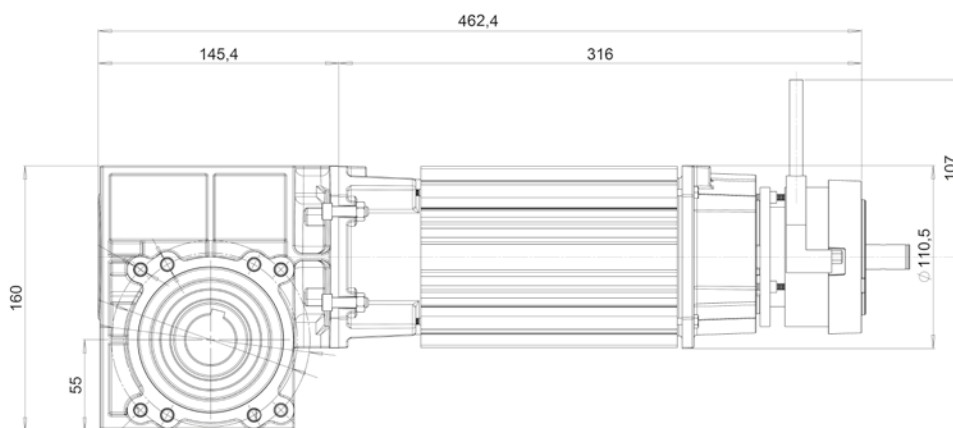

THREE PHASE
BRAKE MOTOR

APPLICATIONS



SECTIONAL DOORS

- MDA / MDB / MDC 050
- $i = 60 / 80$
- Output shaft = D 25,44 / 30 / 31,75 mm
- TS/TBS 0,37 kW; TMD/TBMD 0,55/1,00 kW
- Singleturn absolute encoder and encoder shaft ratio Lgi = 15/30



RAPID DOORS

- MDA / MDB 050
- $i = 10 / 15 / 20$
- Output shaft = D 25 / 30 mm
- TS 0,37 kW; TMD 0,55 / 1,00 kW
- Singleturn absolute encoder and encoder shaft ratio Lgi = 15/30 or incremental encoder on motor



GARAGE DOORS

- MDA 050
- $i = 10 / 20 / 35$
- Output shaft = D 25 mm
- TS 0,37/0,55/1,10/1,50 kW



Technical Sales Support at your side to evaluate your special projects: marketing@motovario.it



MOTOVARIO[®]

HEART OF MOTION

a TECO Group company

DISCOVER OUR WORLD OF SERVICES
MY.MOTOVARIO.COM



MOTOVARIO®

HEART OF MOTION

a **TECO Group** company

Motovario spa

Via Quattro Passi 1/3 - 41043 Formigine (MO) - Italy

Ph. +39 059 579700

marketing@motovario.it - www.motovario.com