

TECHNICAL CATALOGUE

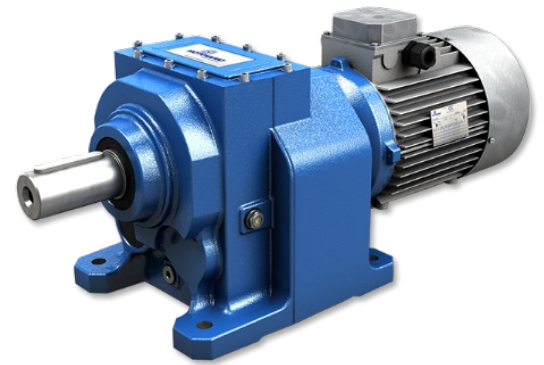

HELICAL GEARED MOTORS

STANDARD **IEC**
DIRECTIVE **ATEX** 

1. GENERAL INFORMATION

1.1	COMPANY PROFILE	4
1.2	PRODUCTS AND SOFTWARE MOTOVARIO	6
1.3	ATEX	10
1.4	SYMBOLS AND FORMULAS	11
1.4.1	Symbols	11
1.4.2	Formulas	12
1.5	PRODUCT SELECTION	13
1.6	SERVICE FACTOR	14
1.7	INSTALLATION	15
1.7.1	Installation	15
1.7.2	Installation	15

2. PRODUCT INFORMATION

2.1	DESIGN FEATURES	16
2.2	TYOLOGY	17
2.2.1	Designation	17
2.2.2	Versions	18
2.2.3	Modularity	20
2.3	MOUNTING POSITIONS	22
2.3.1	Mounting positions	22
2.3.2	Position of terminal box	23
2.4	THERMAL PROTECTOR	24
2.5	CRITICAL APPLICATIONS	25
2.5.1	Critical applications	25
2.5.2	Information	25
2.6	MOTOR FLANGE AVAILABILITY	26
2.6.1	HA Motor flange availability	26
2.6.2	H Motor flange availability	27
2.7	OUTPUT SHAFT BEARINGS	31
2.8	OVERHUNG LOAD	32
2.8.1	Information	32
2.8.2	Input	32
2.8.3	Output	33

2.9	LUBRICATION	34
2.9.1	Information	34
2.9.2	Lubricants	34
2.9.3	Special lubricants	35
2.9.4	Quantity	36
2.10	MOMENTS OF INERTIA	37

3. DIMENSIONS

3.1	REDUCERS/GEARED MOTORS	38
3.1.1	HA31	38
3.1.2	HA.1	39
3.1.3	CHA.1	40
3.1.4	IHA.1	41
3.1.5	HA.2	42
3.1.6	CHA.2	44
3.1.7	IHA.2	46
3.1.8	HA.3	48
3.1.9	CHA.3	50
3.1.10	IHA.3	52
3.1.11	HR..1	54
3.1.12	CHR..1	56
3.1.13	IHR..1	58
3.1.14	H..2/3	60
3.1.15	CH..2/3	62
3.1.16	IH..2/3	64
3.2	ELECTRIC MOTORS	66
3.2.1	Electric motors	66
3.2.2	Standard high efficiency (TS), high (TH) and premium- (TP) motors	68
3.2.3	Nominal power - [kW]	69
3.3	WEIGHTS	70
3.4	SHAFT END	72

4. ACCESSORIES AND OPTIONS

4.1	OUTPUT FLANGE	73
4.2	BACKSTOP DEVICE	74
4.3	REINFORCED OIL SEALS FOR OUTPUT SHAFT	76

5. ATEX AVAILABILITY

5.1	ATEX AVAILABILITY	77
-----	-------------------------	----

6. PERFORMANCES

6.1	H/HA GEARED MOTORS (50Hz)	78
6.2	IH/IHA GEAR REDUCER - 1750 rpm	157
6.3	IH/IHA GEAR REDUCER - 1400 rpm	171
6.4	IH/IHA GEAR REDUCER - 1140 rpm	185
6.5	IH/IHA GEAR REDUCER - 900 rpm	199
6.6	IH/IHA GEAR REDUCER - 700 rpm	213
6.7	IH/IHA GEAR REDUCER - 500 rpm	227

7. SALES CONDITIONS

7.1	SALES CONDITIONS	241
-----	------------------------	-----

Motovario® corporate philosophy aims to promote the company's brand and products at an international level with determination and transparency, while constantly striving to offer innovative solutions for satisfying and anticipating the demand of the market. Motovario® provides technologically advanced solutions in the transmission components field for industrial and civil applications worldwide.

The company

At Formigine, the heart of Modena's industrial district, Motovario® boasts a production plant spanning 50,000 m² that employs 500 people.

1965 Foundation of Motovario

1998 Acquisition of Spaggiari Trasmissioni, an important brand in the mechanical technology sector.

2006 Motovario acquisition by a private investment fund managed by Synergo SGR, in order to guarantee its development and support its expansion throughout the world.

2014 Acquisition of Pujol.

2015 Acquisition by TECO.

At the core of Motovario® lies an evolved production process based on technological solutions that convert power into movement. Motovario® is at the heart of the production processes that drive industries worldwide. Quality and reliability are the company's fundamental assets. Motovario® is present throughout the world with branches in France, Spain, Germany, England, China, the United States and India. The sales network and customer service guarantee immediate and high-quality support to all customers. In addition, the company boasts a worldwide network of MAC (Motovario Assembly Centre). Qualified assembly centres are present, in Italy, Australia, Benelux, Bulgaria, China, Finland, France, India, Ireland, Israel, Malaysia, Poland, Portugal, South Korea, Spain, Sweden, Turkey, United Kingdom, Ukraine and USA. The company is able to offer a wide range of products: speed variators, right-angle, helical-bevel, shaft-mounted, worm gear reducers and gearmotors, electric motors, inverter and inverter drives. Maximum quality and precision are ensured by the cutting-edge technologies implemented in the production process. 170 numerical control machines, served by LGV lines for storage in automatic warehouses, ensure a high standard of efficiency for the Motovario® production department.

The highly automated assembly lines are supported by a specific computerised system. The process statistical control system manages the production process to avoid rejects, by enabling the operator to monitor all the processing phases. The annealing, tempering, hardening and carburizing treatments are carried out inside the plant. The plant operates on a 24-hour basis, including holidays. Reliability, resilience and versatility are the distinctive features of Motovario® products, the most qualified solution to any power transmission requirement.

Main fields OF APPLICATIONS

- Mechanical-electromechanical industry (car washing, pumps, barriers & automatic doors, circuit breakers)
- Ceramic industry (ovens, press feeding systems)
- Food, farming, oenology industry
- Wood, marble, glass industry
- Packaging & bottling industry
- Textile, shoes, leather industry
- Transport, logistic industry
- Construction industry
- Milling, animal husbandry, flower industry
- Machine tools & steel industry
- Mining, quarry, cement industry
- Energy industry (solar, nuclear, biomass, wind)
- Amusement industry (theatres, leisure parks, kiddy rides)
- Chemical & pharmaceuticals industry
- Paper & printing industry
- Plastic & rubber industry
- Telecommunications industry (satellite orientation systems, military radar)
- Engineering and consultant companies

Certifications

Our products can be manufactured to conform with the ATEX Directive 2014/34/UE. In addition, the safety and quality of our motors, geared motors and motovariators is guaranteed by the EAC (EurAsian Conformity) certification, an essential requirement for products exported to the Russian Federation. Our motors are UL certified, which guarantees their safety and quality requirements for the North American market.

Quality CONCEPT

Motovario® has obtained the quality certification renewal of its production system in conformity to the UNI EN ISO 9001:2008 standard. This internationally recognised certification acknowledges the company's commitment and drive geared towards constantly improving products, projects and services offered. Moreover, the company has obtained the OHSAS 18001:1999 (Occupational Health and Safety Assessment Series) certification, which defines the requirements of the workplace safety and health management system.

Research & DEVELOPMENT

Technological innovation: a crucial factor for competing in the market. In the company's 50-year history, research and change have been the pivotal factors in guaranteeing competitiveness at a global level, thanks to increasingly advanced products in terms of performance and reliability. Each year the company invests an increasing amount of its turnover in research and development, geared towards promoting the constant study and analysis of products, control processes and performance certification. In order to ensure that customers receive products that comply with the requested performance levels, the company carries out simulations on all new products, including NVH (Noise, Vibration, Harshness) tests effected in the advanced semi-anechoic chamber.

Customer CARE

Innovative instruments and software applications supporting the technical and logistic requirements of our partners worldwide guarantee a timely and customised service. The experience acquired by Motovario® has led to the creation of the new online portal MyMotovario 4.0, which allows for selecting products and exporting their 3D file. As a result, designers and engineering departments can download the three-dimensional model of the requested product and implement it directly in their own layout. In order to maximise customer service and quality, Motovario® offers all its customers the following online services: Order Tracking, which allows for monitoring the progress of an order in real time, and the Stock Availability service, through which users may check the availability (stock) of our products, both in the Italian plant and in the various branches.

Motovario chooses technological evolution.

Motovario® has chosen technological evolution and actively collaborates with the Faculty of Engineering of the University of Modena and Reggio Emilia and of the University of Bologna.

Reliability, sturdiness, versatility

These are the distinctive traits of Motovario products. A broad range of transmission products that provide a competent, innovative solution to each and every power application need. Cutting-edge tools, unrelenting research efforts and ongoing commitment to upgrading manufacturing equipment to the latest state-of-the-art enable us to offer high quality and performance standards to cater to industry requirements and the broadest variety of applications. Motovario ranks among the leading, well-reputed companies in Italy engaged in the design, manufacture and sales of transmission products for industrial and civil applications. The entire manufacturing process takes place in Formigine and Ubersetto plants, in Modena area, with an overall surface area of over 50.000 sq m. and a workforce of about 500 people. 170 numerically controlled machines and cutting-edge handling, storage and assembly automated systems ensure that all products meet high quality standards. The network includes more than 40 Motovario-certified assembly centres, with the capability to supply products in a broad range of versions, including customised versions, high service capacity and fast response. As a result, our product offering can cater to the needs of all plant engineering sectors, in all industries and for different applications, and includes: speed variators, helical, bevel-helical, parallel helical, worm gear reducers and gearmotors, electric motors and motor-inverters. All of the products we manufacture share such common features as reliability, sturdiness and versatility, topped with a high innovation content. At the heart of a company's technological innovation is the ability to develop integrated tools for computer-aided calculation simulation and management of different processes as part of product development. When simulating operating, setup and process conditions, it is also necessary to analyse and optimize the overall functional design of a product using a synergistic approach. This is achieved by implementing an exhaustive experimental plan, without using interpolation or approximation, as they frequently allow criticalities or any oversizing which is not conducive to maximising quality/cost ratio to go unnoticed.

High-efficiency method for calculation according to standards

A set of specific functions have been developed to this end. A few significant examples include functions to:

- Optimise individual reduction ratios and the combinations of the different reduction stages based on parametrisable target normal series;
- Calculate torque values and maximum permissible external forces for gear reducer units, using iterative numeric algorithms to confirm target life/safety values of components;
- Create databases for loading a FEM structural analysis model by automatically writing all reaction components of bearings under all load conditions to a specific file, with automatic selection of critical cases that need to be verified.

Another goal of the method is to create synergy between calculation according to standards and FEM structural calculation and the implementation of FEM model loading procedures, so as to simplify input data, meshing and constraint criteria

Competitiveness and operational benefits of the new method

This method offers many practical advantages over traditional calculation procedures within the company, namely:

- Iterative optimisation of project since setup stage;
- Accurate assessment of the various service factors and reliability levels for the entire gear reducer unit and for all operating conditions as per catalogue rating or customer specific requirements;
- Faster support to customers in analysing tailored product configurations;
- Integrated corporate databases that can be updated in real-time;

Range extension and ongoing evolution

The steady, significant growth of Motovario Group is achieved thanks to an ongoing search for new calculation and design tools, as well as to customer service. The new tools identified have led to innovation, improved product reliability as well as positive developments in market management. The following software products are used for design, calculation and management:

- Solidworks;
- Kisoft;
- Kissys;
- Ansys;
- FEM modelling analysis software;
- Circuit design and simulation software;
- Specific spreadsheets;
- SAP.

In MyMotovario 4.0 portal, PRODUCT SELECTION includes a section named APPLICATIONS where customers can enter application data and find out which gear reducer suits them best in a matter of minutes.

MOTOVARIO Products

HELICAL GEAR REDUCERS

Cast iron or aluminum casing
 Output shaft up to 90 mm
 Mn₂ up to 8.600 Nm
 Reduction stages 1, 2, 3
 Ratios up to 354
 ATEX units

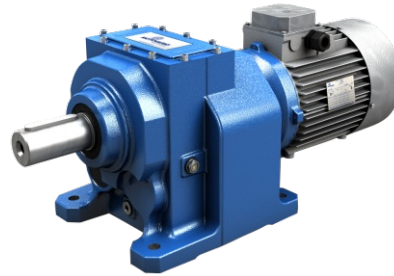
**HELICAL BEVEL GEAR REDUCERS**

Cast iron or aluminum casing
 Output shaft up to 110 mm
 Mn₂ up to 14.000 Nm
 Reduction stages 2, 3
 Ratios up to 443
 ATEX units

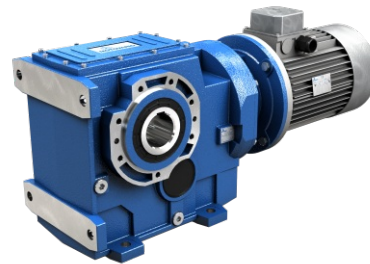
**SHAFT MOUNTED GEAR REDUCERS**

Cast iron
 Output shaft up to 90 mm
 Mn₂ up to 10.250 Nm
 Reduction stages 2, 3
 Ratios up to 395
 ATEX units

**WORM GEAR REDUCERS**

Cast iron or aluminum casing
 Output shaft up to 50 mm
 Mn₂ up to 2.700 Nm
 Ratios up to 1083
 ATEX units



**PARALLEL HELICAL AND
BEVEL HELICAL GEAR REDUCERS
FOR MIDDLE HEAVY INDUSTRY**

Cast iron casing
Output shaft up to 180 mm
Mn₂ up to 110.000 Nm
Reduction stages 1, 2, 3, 4
Ratios up to 636
Atex units

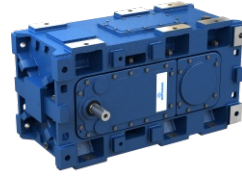

**MOTOVARIATORS AND
MOTOVARIATOR-GEAR REDUCERS**

Cast iron or aluminum casing
Ratios infinite
Mn₂ up to 5.000 Nm
Atex units



<p>ELECTRIC MOTORS</p> <p>Power ratings up to 90 kW Poles 2, 4, 6 Three-phase and single-phase, built-in brake, dual polarity Protection class up to IP66</p>	
<p>DRIVES</p> <p>DRIVON - motoinverter</p> <p>Three phase and single phase power supply High dynamics sensorless vectorial control Power ratings up to 5,5 kW Standard integrated STO Integrated field bus Optional field bus</p>	



ATEX Certification

The gear reducers described in this catalogue, defined as “ATEX”, were designed and manufactured in compliance with: Directive **ATEX 2014/34/UE**.

If used by following the instructions set forth in the INSTALLATION AND USE INSTRUCTIONS Atex Manual (provided as an attachment to the supplied products), ATEX MOTOVARIO gear reducers can be used in one of the following environments:

Group II

Category 2G and 2D

Zone 1/21 for gases and dusts (gas group IIB) with the following protection methods:

Protection against ignition:

EN13463-5 (c) constructional safety

EN13463-8 (k) liquid immersion

Group II

Category 3G and 3D

Zone 2/22 for gases and dusts

Protection against ignition:

EN13463-5 (c) constructional safety

The room temperature envisaged for the application must range between -20 and + 40 °C (*).

The products certified for use in Zone 1/21 can be used also in Zone 2/22. To identify the environment inside which the Atex certification of the special gear reducer is limited, refer to Atex Performance Tables.

The classified units are manufactured and marked to comply with the provisions of Directive **ATEX 2014/34/UE**.

UNINTENDED USE

It is strictly forbidden to use the gear reducer:

- inside an area with equipment category I (mines likely to become endangered by firedamp);
- inside an Area classified as more severe than specified on product label;
- at a room temperature not falling within the specified limits (*);
- under conditions (P1, n1, M2) that, even individually, exceed the values specified inside Atex Performance Tables.

1.4.1 Symbols

Physical dimension	Symbol	Symbol units of measure	Input	Output
Power	P	[kW]	P ₁	P ₂
Requested power	Pr	[kW]	Pr ₁	Pr ₂
Nominal power	Pn	[kW]	Pn ₁	Pn ₂
Torque	M	[Nm]	M ₁	M ₂
Nominal torque	Mn	[Nm]		Mn ₂
Requested torque	Mr	[Nm]	Mr ₁	Mr ₂
Speed	n	[rpm]	n ₁	n ₂
Force	F	[N]		
Radial load	Fr	[N]	Fr ₁	Fr ₂
Axial load	Fa	[N]	Fa ₁	Fa ₂
Reduction ratio	i			
Dynamic efficiency	η_d			
Service factor	f.s.			
Static	s			
Dynamic	d			
Calculated	c			
Maximum	max			
Minimum	min			
Moment of inertia	J	[kgm ²]	J ₁	
Ambient temperature	T _{amb}	[°C]		
Dimension		[mm]		

1.4.2 Formulas

REDUCER		
Starting or stopping time	$t = v / a$	[s]
Velocity in rotary motion	$v = \pi * d * n / 60$ $v = \omega * r$	[m/s]
Speed velocity Angular velocity	$n = 60 * v / (\pi * d)$ $\omega = v / r$	[rpm] [rad/s]
Acceleration or deceleration according to a starting / stopping time	$a = v / t$	[m/s ²]
Angular acceleration	$\alpha = n / (9,55 * t)$ $\alpha = \omega / t$	[rad/s ²]
Starting or stopping distance (according to acceleration / deceleration or angular velocity)	$s = a * t^2 / 2$ $s = v * t / 2$	[m]
Horizontal translation force	$F = \mu * m * g$	[N]
Vertical translation force (lifting)	$F = m * g$	
Inclined plane translation force	$F = m * g (\mu * \cos\beta + \sin\beta)$	
m= mass [kg]; g= gravity acceleration [m/s ²]; μ= friction coefficient; β= angle of inclination		
Moment of inertia	$J = m * v^2 / \omega^2$	[kgm ²]
Torque	$M = F * d / 2$ $M = J * \omega / t$	[Nm]

MOTOR and GEARMOTOR		
Starting time	$t_a = (J_{ext} + J_m) * n_n / 9,55 + (M_{peak} - M_r)$	[s]
Braking time	$t_s = (J_{ext} + J_m) * n_n / 9,55 + (M_{peak} + M_r)$	[s]
Motor rotation angle during starting	$\varphi = n_n * t_a / 19,1$	[rad]
Motor rotation angle during braking	$\varphi = n_n * t_s / 19,1$	[rad]
Power available at the shaft of single phase motor	$P = V * I * \eta * \cos\omega$	[W]
Power available at the shaft of three phase motor	$P = 1,73 * V * I * \eta * \cos\omega$	[W]

RUNNING at 60Hz		
Speed velocity at 60Hz	$n_{60Hz} = 1,2 * n_{50Hz}$	[rpm]
Power at 60Hz	$P_{1\ 60Hz} = P_{1\ 50Hz} * V_{60Hz} / V_{50Hz}$	[kW]
If input voltage at 60 Hz (V _{60Hz}) corresponds to winding voltage at 50 Hz (V _{50Hz}), power doesn't change $P_{1\ 60Hz} = P_{1\ 50Hz}$		
If input voltage at 60 Hz (V _{60Hz}) is 20% higher than winding voltage at 50 Hz (V _{50Hz}), power increases by 20% $P_{1\ 60Hz} = 1,2 P_{1\ 50Hz}$		
Torque at 60Hz	$M_{60Hz} = M_{50Hz} * P_{1\ 60Hz} / (1,2 * P_{1\ 50Hz})$	[Nm]
Service factor at 60Hz	$f.s_{60Hz} = f.s_{50Hz} * 1,175 * P_{1\ 50Hz} / P_{1\ 60Hz}$	-

For correctly selecting a gear reducer or geared motor, several essential pieces of data are required:

1. The rotational input speed to the gear reducer (n_1) and the rotational output speed (n_2). Through these two values it is possible to calculate the reduction ratio (i) of the gear reducer using the following formula: $i = n_1/n_2$
2. The torque required by the application (Mr_2).

The geared motor or gear reducer can be selected once this data is known.

This guide helps you to select the right product in just a few steps:

Geared motor selection

1. Determine the application's actual service factor (**s.f.**). This parameter depends on the type of load of the powered machine, the number of starts per hour and the hours of operation (refer to the "Service factor" paragraph).
2. Calculate the input power Pr_1 using the required torque value Mr_2 , the speed n_2 and dynamic efficiency value. $Pr_1 = (Mr_2 * n_2) / (9550 * \eta_d)$. The dynamic efficiency value depends on the type of gear reducer and on the number of gear reduction stages. (To calculate the efficiency value see its page).
3. Consult the geared motor performance tables and identify a normalised power value Pn_1 exceeding the required power Pr_1 , such that: $Pn_1 \geq Pr_1$
4. Once the suitable nominal power has been identified, select the geared motor capable of generating the rotational speed closest to the desired n_2 value and with service factor s.f. greater or equal to that required by the application.



For ATEX product selection, use the service factor "f.s. ATEX".

In the geared motor selection tables the combinations include 2-pole, 4-pole and 6-pole motors powered at 50Hz.

Gear reducer selection

1. Determine the application's service factor (**s.f.**) (consult to the "Service factor" paragraph on its page) .
2. Calculate the reduction ratio i from the requested output speed n_2 and from the input speed n_1 . $i = n_1/n_2$
3. Calculate the torque Mc_2 for selecting the gear reducer through the torque required by the application Mr_2 and the service factor s.f.: $Mc_2 = Mr_2 * (f.s.)$
4. Consult the Gear Reducer Performance tables looking for the reducer that, with the reduction ratio closer to the calculated one, has a nominal torque Mn_2 so that: $Mn_2 \geq Mc_2$



For ATEX product Selection, refer to ATEX Gear Reducer Performance tables.

Checks

Once the gear reducer or geared motor has been selected, the following checks should be performed:

A. Thermal power

The gear reducer's thermal power must be equal to or greater than the installed mechanical power, or the power required by the application according to the indications contained in the section (refer to the "Thermal power" paragraph).

B. Maximum torque

Generally, the maximum torque (peak instantaneous load) that can be applied to the gear reducer must not exceed 200% of the nominal torque Mn_2 (ATEX - M_2max).

C. Radial loads

1. Verify that the radial loads acting on the input and/or output shafts are within with the values indicated in the catalogue. If they exceed these values, increase the size of the gear reducer or modify the external load capacity. During the checking phase, it is important to remember that the values indicated in the catalogue refer to loads acting on the mid-point of the shaft protrusion, therefore, if the load is applied to a different position, appropriate formulas must be used to calculate the admissible load in the desired position (refer to the "Radial loads" paragraph).
2. If accessory output shafts are present, make sure that the applied load is compatible with shaft size. If help is needed: contact MOTOVARIO TECHNICAL SERVICE.

D. If an electric motor is going to be fitted to the selected gear reducer, check for its applicability by referring to the configuration table (see paragraph "Motor flange availability"). From IEC 180 motors, verify if necessary to support the motor with feet. In case of need please contact MOTOVARIO TECHNICAL SERVICE.

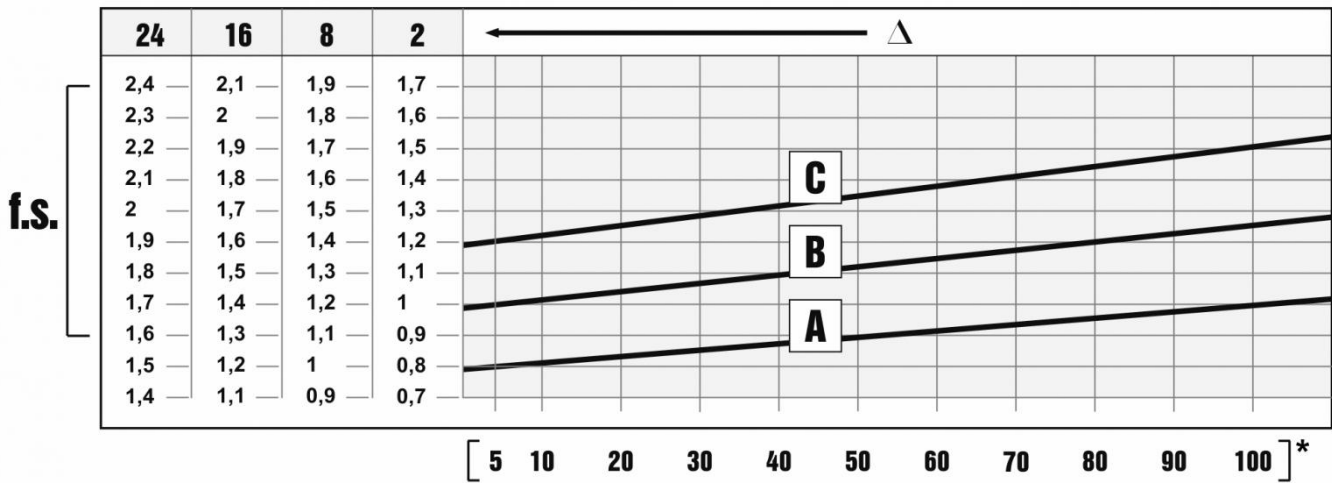

The service factor (f.s.) depends on the operating conditions the gear reducer is subjected to. The parameters that need to be taken into consideration to select the most adequate service factor correctly comprise:

- type of load of the operated machine : A - B - C
- length of daily operating time: hours/day (Δ)
- start-up frequency: starts/hour (*)

LOAD:

- **A** - uniform = $f_a \leq 0,3$
- **B** - moderate shocks = $f_a \leq 3$
- **C** - heavy shocks = $f_a \leq 10$

$f_a = J_e/J_m$

- J_e [kgm^2] moment of reduced external inertia at the drive-shaft
- J_m [kgm^2] moment of inertia of motor

If $f_a > 10$ call MOTOVARIO TECHNICAL SERVICE.

- A. Screw feeders for light materials, fans, assembly lines, conveyor belts for light materials, small mixers, lifts, cleaning machines, fillers, control machines.
- B. Winding devices, woodworking machine feeders, goods lifts, balancers, threading machines, medium mixers, conveyor belts for heavy materials, winches, sliding doors, fertilizer scrapers, packing machines, concrete mixers, crane mechanisms, milling cutters, folding machines, gear pumps.
- C. Mixers for heavy materials, shears, presses, centrifuges, rotating supports, winches and lifts for heavy materials, grinding lathes, stone mills, bucket elevators, drilling machines, hammer mills, cam presses, folding machines, turntables, tumbling barrels, vibrators, shredders.

1.7.1 Installation

To install the gear reducer it is necessary to note the following recommendations:

- Check the correct direction of rotation of the gear reducer output shaft before fitting the unit to the machine.
- In the case of particularly lengthy periods of storage (4/6 months), if the oil seal is not immersed in the lubricant inside the unit, it is recommended to change it since the rubber could stick to the shaft or may even have lost the elasticity it needs to function properly.
- Whenever possible, protect the gear reducer against solar radiation and bad weather.
- Ensure the motor cools correctly by ensuring good passage of air from the fan side.
- In the case of ambient temperatures $< -5^{\circ}\text{C}$ or $> +40^{\circ}\text{C}$ call MOTOVARIO TECHNICAL SERVICE.
- The various parts (pulleys, gear wheels, couplings, shafts, etc.) must be mounted on the shafts using special threaded holes or other systems that anyhow ensure correct operation without risking damage to the bearings or external parts of the units. Lubricate the surfaces in contact to avoid seizure or oxidation.
- Painting must definitely not go over rubber parts and the holes on the breather plugs, if any.
- For units equipped with oil plugs, replace the closed plug used for shipping with the special breather plug.
- Check the correct level of the lubricant through the indicator, if there is one.
- Starting must take place gradually, without immediately applying the maximum load.
- When there are parts, objects or materials under the motor drive that can be damaged by even limited spillage of oil, special protection should be fitted.

1.7.2 Installation

Assembling motor on pam flange

When the unit is supplied without motor, it is necessary to follow these recommendation to ensure the correct assembly of the electric motor. Check that the tolerances for the motor shaft and flange correspond to the "standard". Carefully clean the shaft, spigot and surfaces of the flange removing traces of paint and dirt, and confirm the key is fitted correctly. Fit the half coupling/sleeve to the motor shaft (see picture) taking care to ensure the motor shaft and bearings are not damaged by avoiding excessive force and where necessary using assembly equipment. Place the couplings elastic element onto the motor half coupling and position the motor up to the gear unit ensuring the coupling element is aligned with the driven half coupling. Complete the assembly using the fixing bolts. Key-ways with tightened tolerances.



In case of ATEX units, fit gasket (to be requested to Motovario) between PAM flange and motor.

Flexible joint

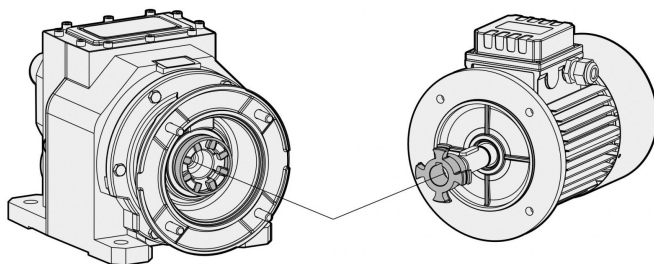

PAM Sleeve

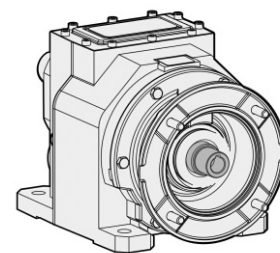

Motovario products are supplied with the following surface treatment features:

Die-cast aluminium alloy cases for gears

Die-cast materials undergo the following surface cleaning operations:

- De-burring by means of a mechanically operated shearing system.
- Accurate shot-peening.
- Painting.
- Washing and passivation.

Grey-coloured cast-iron cases for gears

- Die-cast materials are always painted.

Grey-coloured cast-iron inspection cover: The gear reducer H... series with 2, 3 stages sizes 125, 140 are supplied with grey-coloured cast-iron closing cover and a metal nameplate printed.



Painting specifications:

- Orange-peel blue epoxy-polyester RAL 5010. Polyester resin based heat-hardening powders, altered with epoxy resins.

Mechanical properties: Tests carried out onto degreased Unichim white lattens (film thickness: 60 microns) comply with the following specifications: adherence (ISO2409).

Heat resistance: 24 HOURS AT 150°C.

Corrosion strength: ASTM B 117/97 salt fog from 100 to 500 hours depending on the support's preliminary treatment.

Performance:

- Loading capacity in accordance with DIN 3990, ISO 6336, AGMA 2101, ISO 10300, DIN 3991, ISO 281, DIN 743.

Dynamic η :

- The efficiency is the ratio between the output power P_2 and the power absorbed by the gear reducer P_1 : $\eta = P_2/P_1$.

H/HA-range helical gear reducers have an average value equal to:

H..1 stages = 0,97

H..2 stages = 0,96

H..3 stages = 0,94

2.2.1 Designation

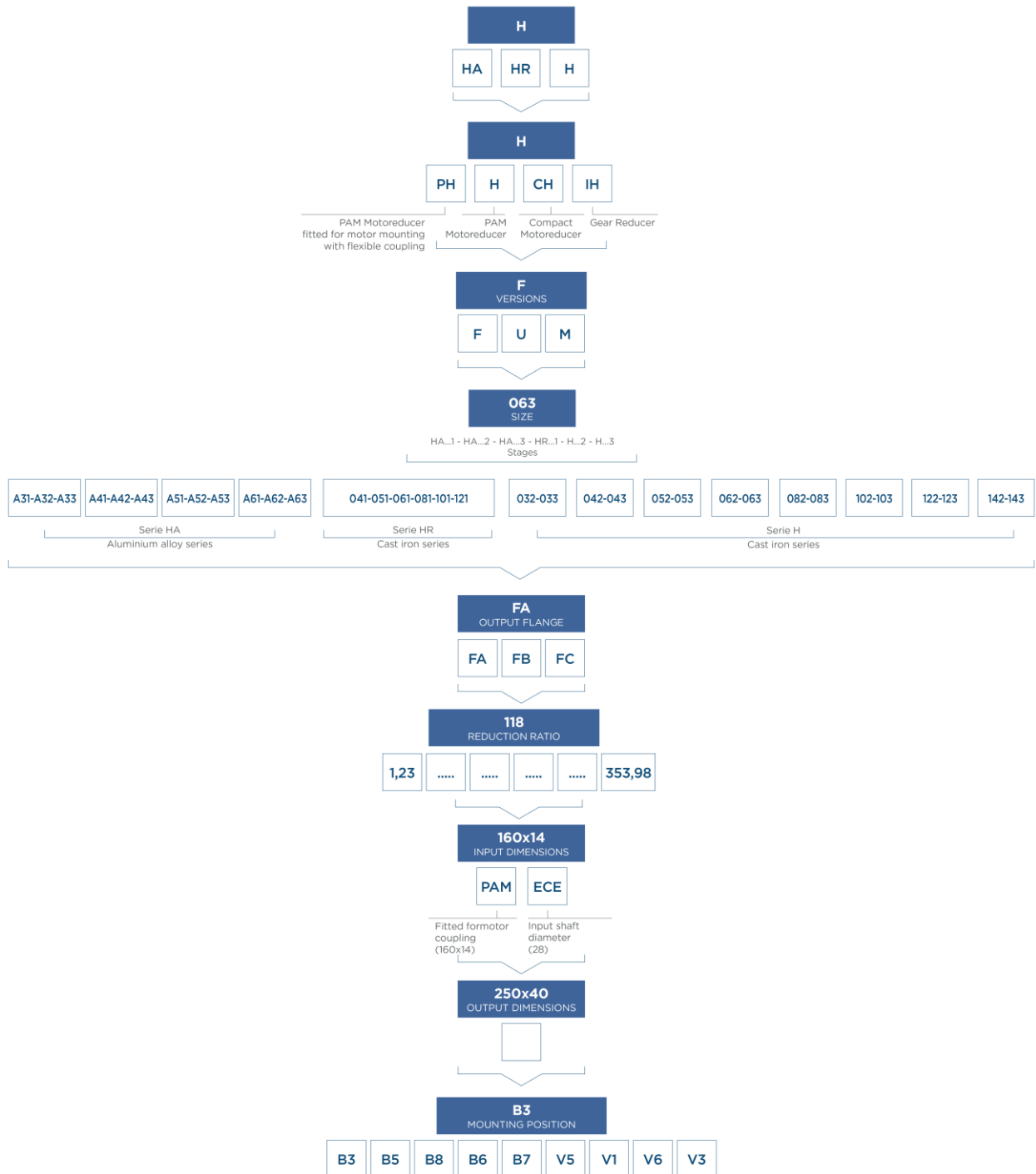

2.2.2 Versions

A30 - A40 - A50 - A60

SINGLE STAGE

CASING WITH FOOT

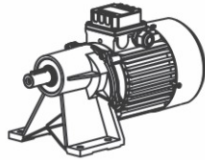

F CASING WITH FLANGE

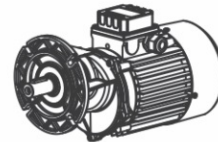

A31 CASING WITH FLANGE

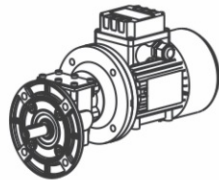

DOUBLE AND TRIPLE STAGE

CASING WITH FOOT

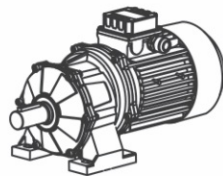

F CASING WITH FLANGE

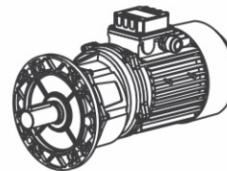

U CASING UNIVERSAL

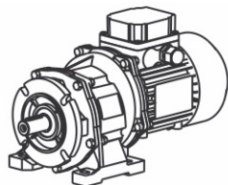

NOTE ATEX GEAR REDUCERS:
AVAILABLE FOR 3G/3D CERTIFICATION, ONLY.

030 - 040 - 050 - 060 - 080 - 100 - 120 - 140

SINGLE STAGE

CASING WITH FOOT

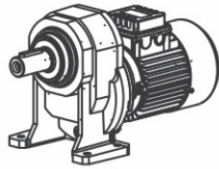

F CASING WITH FLANGE

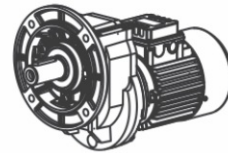

U CASING UNIVERSAL

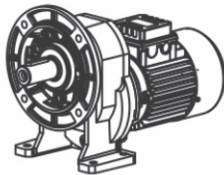

M CASING MONO

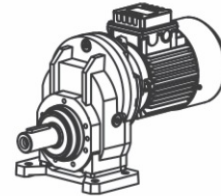

DOUBLE AND TRIPLE STAGE

CASING WITH FOOT

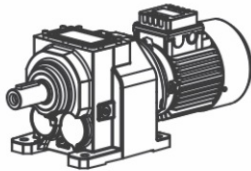

F CASING WITH FLANGE

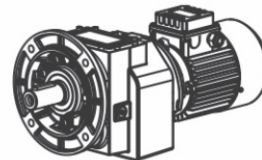

U CASING UNIVERSAL

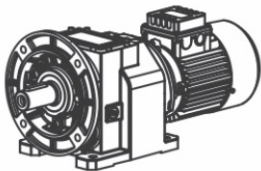

2.2.3 Modularity

HA ALUMINIUM ALLOY SERIES

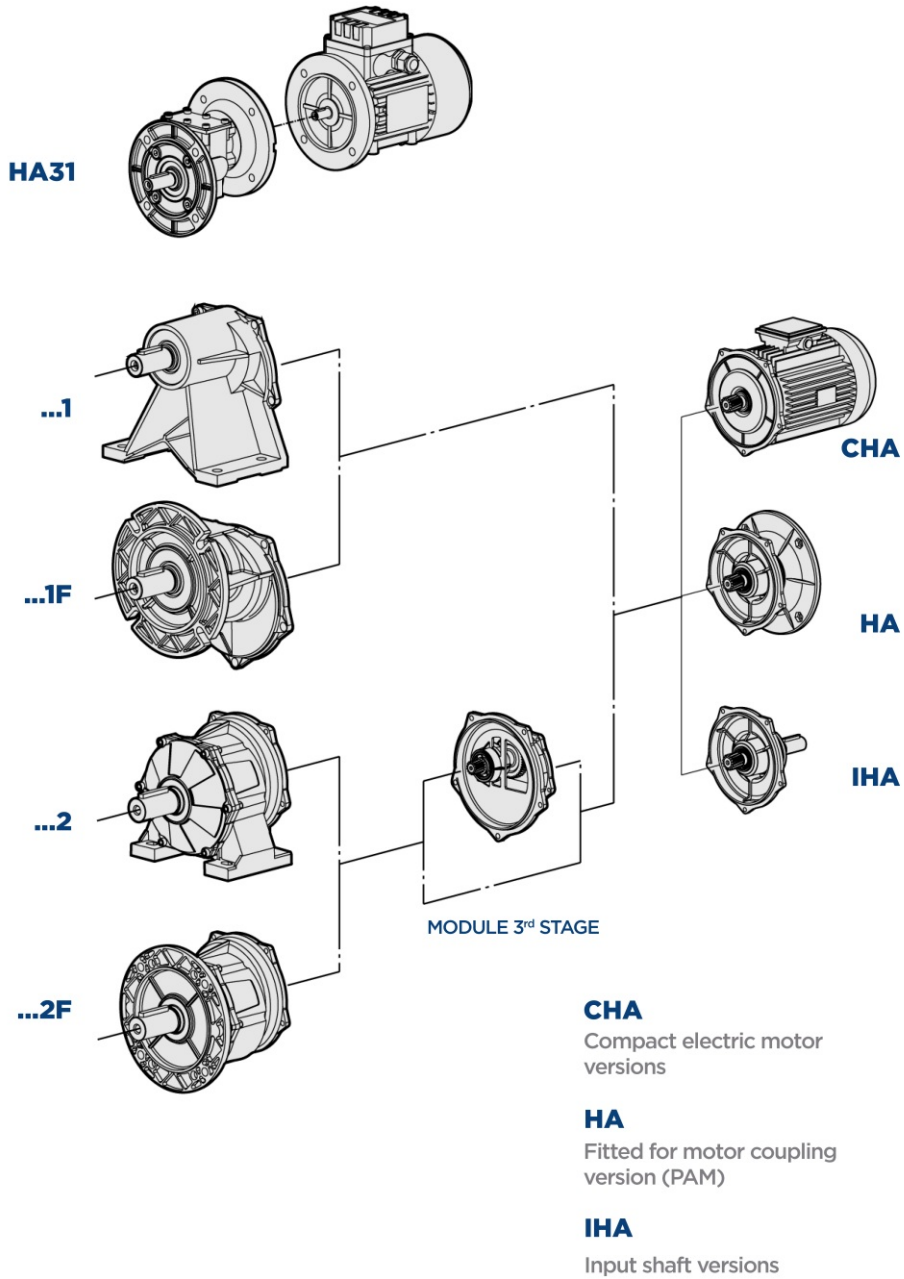

H GREY CAST IRON SERIES

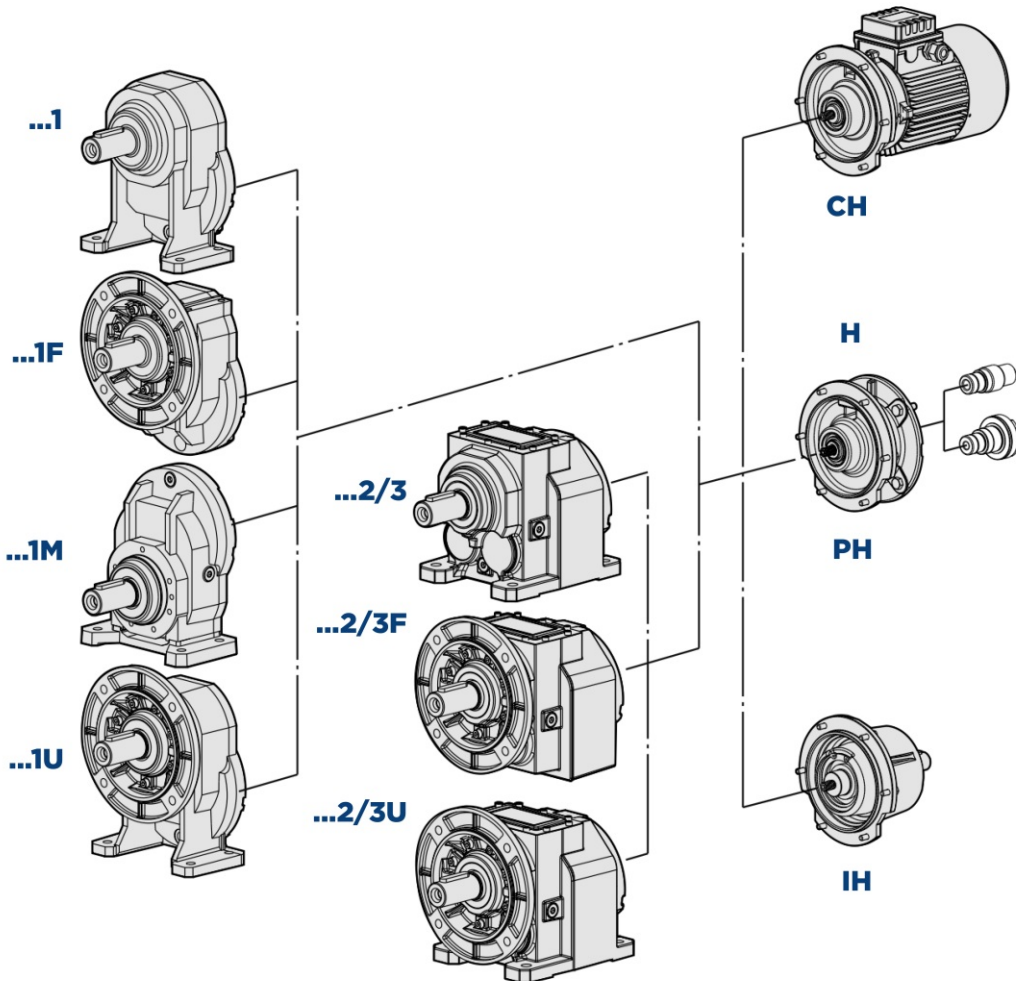

CH
Compact electric motor versions

H
Fitted for motor coupling version (PAM)

PH
Fitted for motor mounting with flexible coupling

IH
Input shaft versions

2.3.1 Mounting positions

The mounting position of the gear unit identifies its space orientation. B3 mounting position, as from a technical point of view, ensures lower oil splash, better lubrication and less heating.

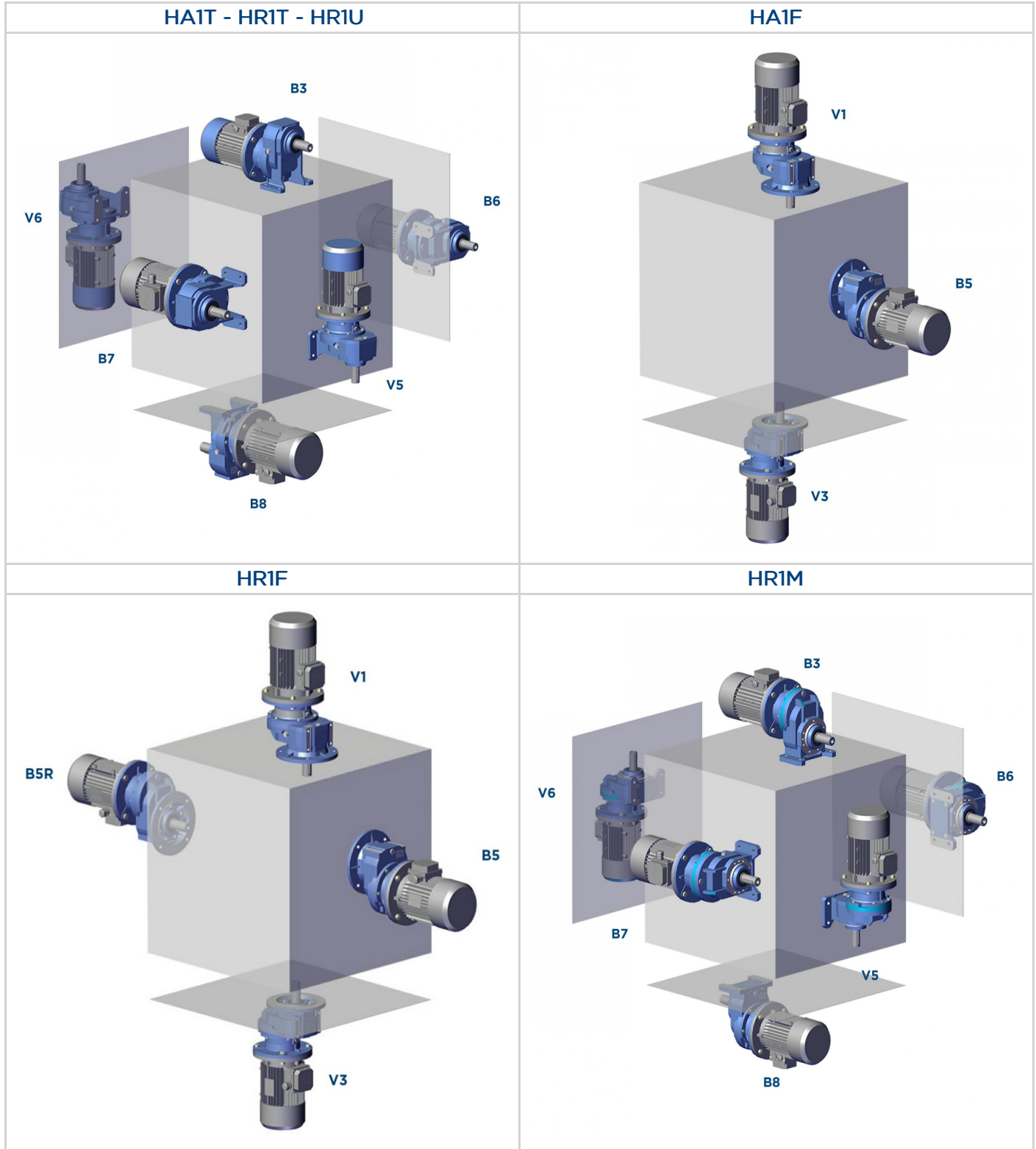

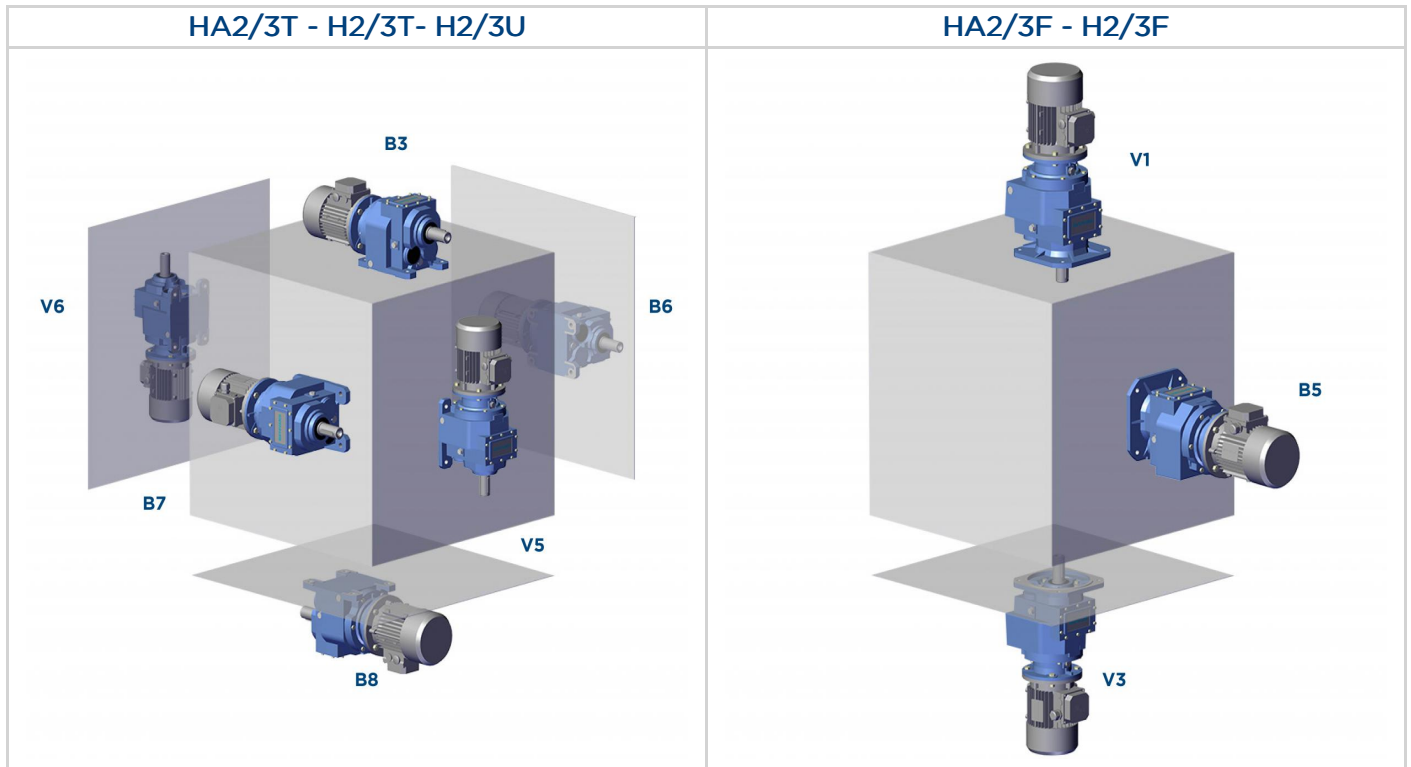

2.3.2 Position of terminal box

Unless otherwise specified when ordering, the gear reducer is supplied with terminal box in position 1.

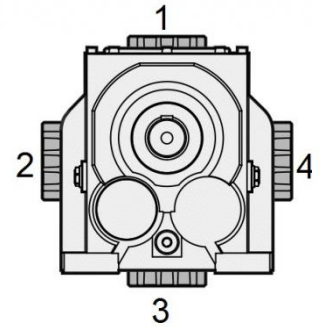
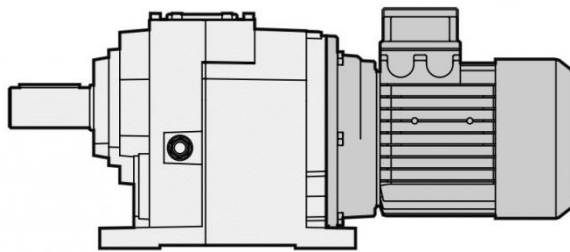
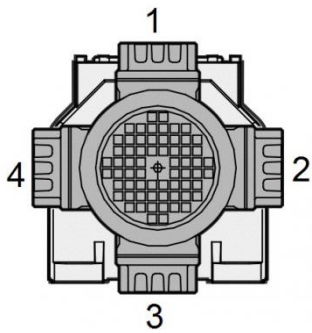

2.4 THERMAL PROTECTOR

The reducers of the sizes and ratios in the tables below are provided with a thermal protector (supplied and supplied by the customer). It is a PTC probe (see Fig. 1) with a trigger temperature of 120 °C. The customer shall perform the electric connection to the main electric panel to ensure the resistance thermometer correct operation regardless of the connections necessary for the system operation. The connection must apply the positive safety logic. Main powerboard, connections and logic must, taken together, provide a locking system to prevent, in the event of a shutdown, the unwanted start-up of the device. In case of intervention of the PTC probe, wait about 10 min. before resetting the main powerboard.

Unit electric characteristics:

Power to sensor <280 mW
 Voltage to sensor <30 Vdc
 Current to sensor <8 mA

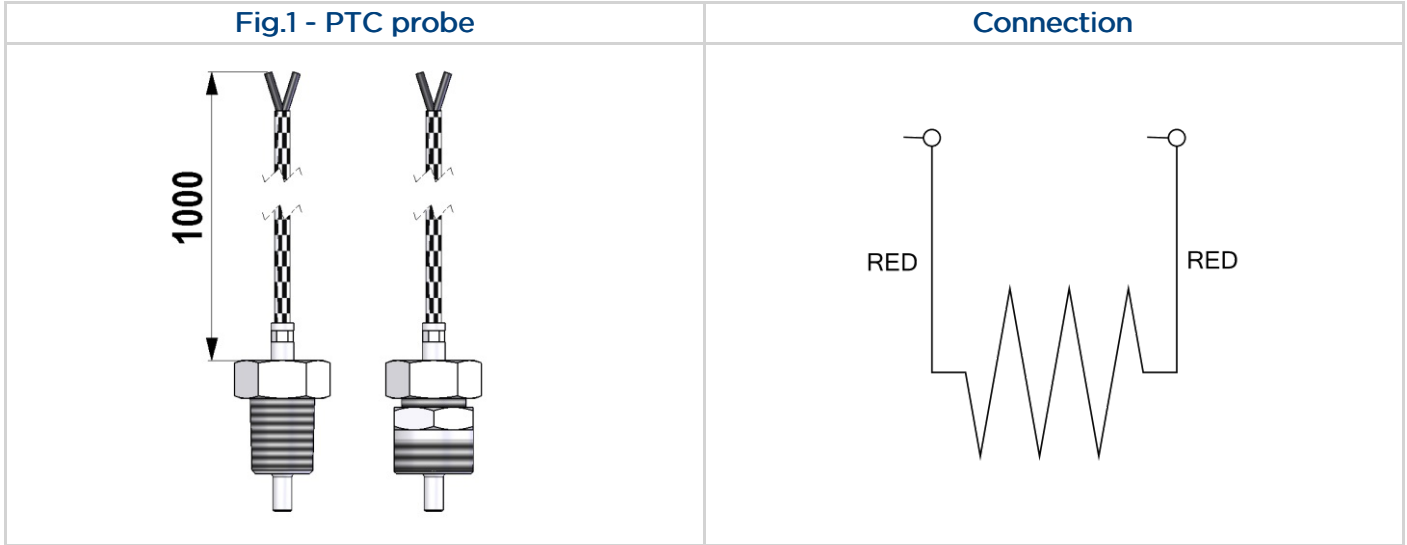

	i		i
H122	5,27	H142	5,27
	5,78		6,36
	7,05		7,04
	7,74		7,84
	8,48		9,45
	10,35		10,47
	12,66		13,07
	13,86		15,75
	16,92		17,45
	19,32		20,04
20,57	24,15		
			26,76

2.5.1 Critical applications

H	A31	A30	A40	A50	A60
n1 > 1800	B	B	B	B	B
V3 - V6	B	B	B	B	B

H	030	040	050	060	080	100	125	140
V5 - V1: 1500 < n1 < 1800	✓	✓	✓	✓	✓	✓	B	B
n1 > 1800	B	B	B	B	B	B	A	A
V3 - V6	B	B	B	B	B	B	B	B

✓ Verified application

A Application not recommended

B Check the application and/or call MOTOVARIO TECHNICAL SERVICE.

2.5.2 Information

The performance given in the catalogue correspond to mounting position B3 or similar, when the first stage is not entirely immersed in oil. For other mounting positions and/or particular input speeds, refer to the tables that highlight different critical situations for each size of gear reducer. It is also necessary to take due consideration of and carefully assess the following applications by calling MOTOVARIO TECHNICAL SERVICE:

- To avoid the use as multiplier.
- Use in services that could be hazardous for people if the gear reducer fails.
- Applications with especially high inertia.
- Use as a lifting winch.
- Applications with high dynamic strain on the case of the gear reducer.
- In places with T_{amb} under -5°C or over 40°C .
- Use in chemically aggressive environments.
- Use in a salty environment.
- Mounting positions not envisaged in the catalogue.
- Use in radioactive environments.
- Use in environments pressures other than atmospheric pressure.

Avoid applications where even partial immersion of the reducer is required.

In the presence of overloading due to full load, braking, shocks or other static and dynamic causes, please verify that the peak torque is less than $2 \cdot Mn_2$.

2.6.1 HA Motor flange availability

B10 = Compact electric motor versions.

These tables report all possible dimensions. Please verify service factor.



NOTE Atex gear reducers sizes HA32-HA43-HA42-HA43-HA52-HA53-HA62-HA63: available for 3G/3D certification, only.

	i	O63	O71	O80	O90	100	112
CH A32	5,38 ÷ 30,55	B10	B10	B10			
CH A32	35,44 ÷ 60,67	B10	B10				
CH A33	51,32 ÷ 166,61	B10	B10				
CH A33	193,3 ÷ 347,29	B10	B10	B10			
CH A41	1,45 ÷ 5,45	B10	B10	B10			
CH A41	7,88 ÷ 10,83	B10	B10				
CH A42	5,38 ÷ 30,55	B10	B10	B10	B10		
CH A42	35,44 ÷ 60,67	B10	B10				
CH A43	51,32 ÷ 166,61	B10	B10	B10	B10		
CH A43	193,3 ÷ 240,55	B10	B10				
CH A51	1,45 ÷ 5,45	B10	B10	B10	B10		
CH A51	7,88 ÷ 10,83	B10	B10				
CH A52	5,14 ÷ 25,43			B10	B10	B10	B10
CH A52	29,89 ÷ 61,87			B10	B10		
CH A53	49,8 ÷ 163,05	B10	B10	B10	B10		
CH A53	200,27 ÷ 353,98	B10	B10				
CH A61	1,33 ÷ 4,38			B10	B10	B10	B10
CH A61	7,75 ÷ 10,67			B10	B10		
CH A62	5,14 ÷ 25,43			B10	B10	B10	B10
CH A62	29,89 ÷ 61,87			B10	B10		
CH A63	49,8 ÷ 163,05	B10	B10	B10	B10		
CH A63	200,27 ÷ 353,98	B10	B10				

	i	O63	O71	O80	O90	100	112
H A31	2,55 ÷ 4,75	B5	B5	B5			
H A31	5,1 ÷ 7,88	B5	B5				
H A31	10,83	B5					
H A32	5,38 ÷ 30,55	B5	B5-B14	B5-B14			
H A32	35,44 ÷ 60,67	B5	B5-B14				
H A33	51,32 ÷ 166,61	B5	B5-B14				
H A33	193,3 ÷ 347,29	B5	B5-B14	B5-B14			
H A41	1,45 ÷ 5,45	B5	B5-B14	B5-B14			
H A41	7,88 ÷ 10,83	B5	B5-B14				
H A42	5,38 ÷ 30,55	B5	B5-B14	B5-B14	B5-B14		
H A42	35,44 ÷ 60,67	B5	B5-B14				
H A43	51,32 ÷ 166,61	B5	B5-B14	B5-B14	B5-B14		
H A43	193,3 ÷ 240,55	B5	B5-B14				
H A51	1,45 ÷ 5,45	B5	B5-B14	B5-B14	B5-B14		
H A51	7,88 ÷ 10,83	B5	B5-B14				
H A52	5,14 ÷ 25,43			B5-B14	B5-B14	B5-B14	B5-B14
H A52	29,89 ÷ 61,87			B5-B14	B5-B14		
H A53	49,8 ÷ 163,05	B5	B5-B14	B5-B14	B5-B14		
H A53	200,27 ÷ 353,98	B5	B5-B14				
H A61	1,33 ÷ 4,38			B5-B14	B5-B14	B5-B14	B5-B14
H A61	7,75 ÷ 10,67			B5-B14	B5-B14		
H A62	5,14 ÷ 25,43			B5-B14	B5-B14	B5-B14	B5-B14
H A62	29,89 ÷ 61,87			B5-B14	B5-B14		
H A63	49,8 ÷ 163,05	B5	B5-B14	B5-B14	B5-B14		
H A63	200,27 ÷ 353,98	B5	B5-B14				

2.6 MOTOR FLANGE AVAILABILITY

2.6.2 H Motor flange availability

B11 = Compact electric motor versions.

These tables report all possible dimensions. Please verify service factor.

*Configuration supplied with thermal protector.

**For motor size 063 the PH version does not exist.



NOTE Atex geared motors (versions with compact electric motor B11): available for 3G/3D certification, only.

CH - H - PH 032					
i	071	080	090	100	112
4,70	B5-B11	B5-B11	B5-B11	B5-B11	B5-B11
6,23	B5-B11	B5-B11	B5-B11	B5-B11	B5-B11
7,76	B5-B11	B5-B11	B5-B11	B5-B11	B5-B11
8,87	B5-B11	B5-B11	B5-B11	B5-B11	B5-B11
10,14	B5-B11	B5-B11	B5-B11	B5-B11	B5-B11
11,76	B5-B11	B5-B11	B5-B11	B5-B11	B5-B11
13,72	B5-B11	B5-B11	B5-B11	B5-B11	B5-B11
14,66	B5-B11	B5-B11	B5-B11	B5-B11	B5-B11
16,77	B5-B11	B5-B11	B5-B11	B5-B11	B5-B11
18,20	B5-B11	B5-B11	B5-B11	B5-B11	B5-B11
19,90	B5-B11	B5-B11	B5-B11		
22,68	B5-B11	B5-B11	B5-B11	B5-B11	B5-B11
23,83	B5-B11	B5-B11	B5-B11		
26,39	B5-B11	B5-B11	B5-B11		
29,70	B5-B11	B5-B11	B5-B11		
32,89	B5-B11	B5-B11	B5-B11		
37,92	B5-B11	B5-B11	B5-B11		
41,40	B5-B11	B5-B11	B5-B11		
47,25	B5-B11	B5-B11	B5-B11		

CH - H - PH 033				
i	**063	071	080	090
53,59	B5-B11	B5-B11	B5-B11	B5-B11
66,78	B5-B11	B5-B11	B5-B11	B5-B11
74,84	B5-B11	B5-B11	B5-B11	B5-B11
99,27	B5-B11	B5-B11	B5-B11	B5-B11
108,05	B5-B11	B5-B11		
123,71	B5-B11	B5-B11	B5-B11	B5-B11
143,33	B5-B11	B5-B11		
178,61	B5-B11	B5-B11		
197,17	B5-B11	B5-B11		
245,70	B5-B11	B5-B11		

CHR - HR - PHR 041			
i	071	080	090
1,44	B5-B11	B5-B11	B5-B11
2,00	B5-B11	B5-B11	B5-B11
2,55	B5-B11	B5-B11	B5-B11
2,71	B5-B11	B5-B11	B5-B11
3,11	B5-B11	B5-B11	B5-B11
3,59	B5-B11	B5-B11	B5-B11
4,20	B5-B11	B5-B11	B5-B11
5,00	B5-B11	B5-B11	B5-B11
5,50	B5-B11	B5-B11	B5-B11
6,09	B5-B11	B5-B11	B5-B11
7,67	B5-B11	B5-B11	B5-B11
8,75	B5-B11	B5-B11	B5-B11

CH - H - PH 042					
i	071	080	090	100	112
5,46	B5-B11	B5-B11	B5-B11	B5-B11	B5-B11
7,19	B5-B11	B5-B11	B5-B11	B5-B11	B5-B11
8,91	B5-B11	B5-B11	B5-B11	B5-B11	B5-B11
10,31	B5-B11	B5-B11	B5-B11	B5-B11	B5-B11
11,80	B5-B11	B5-B11	B5-B11	B5-B11	B5-B11
13,57	B5-B11	B5-B11	B5-B11	B5-B11	B5-B11
15,96	B5-B11	B5-B11	B5-B11	B5-B11	B5-B11
19,00	B5-B11	B5-B11	B5-B11	B5-B11	B5-B11
21,00	B5-B11	B5-B11	B5-B11	B5-B11	B5-B11
23,15	B5-B11	B5-B11	B5-B11		
26,04	B5-B11	B5-B11	B5-B11	B5-B11	B5-B11
27,50	B5-B11	B5-B11	B5-B11		
30,45	B5-B11	B5-B11	B5-B11		
34,10	B5-B11	B5-B11	B5-B11		
37,76	B5-B11	B5-B11	B5-B11		
43,75	B5-B11	B5-B11	B5-B11		
47,53	B5-B11	B5-B11	B5-B11		
54,25	B5-B11	B5-B11	B5-B11		

CH - H - PH 043				
i	*063	071	080	090
61,83	B5-B11	B5-B11	B5-B11	B5-B11
76,67	B5-B11	B5-B11	B5-B11	B5-B11
87,05	B5-B11	B5-B11	B5-B11	B5-B11
114,55	B5-B11	B5-B11	B5-B11	B5-B11
125,69	B5-B11	B5-B11		
142,04	B5-B11	B5-B11	B5-B11	B5-B11
165,38	B5-B11	B5-B11		
205,07	B5-B11	B5-B11		
227,50	B5-B11	B5-B11		
282,10	B5-B11	B5-B11		

2.6 MOTOR FLANGE AVAILABILITY

CHR - HR - PHR 051					
i	071	080	090	100	112
1,27		B5-B11	B5-B11	B5-B11	B5-B11
1,42		B5-B11	B5-B11	B5-B11	B5-B11
2,13		B5-B11	B5-B11	B5-B11	B5-B11
2,57	B5-B11	B5-B11	B5-B11	B5-B11	B5-B11
3,17	B5-B11	B5-B11	B5-B11	B5-B11	B5-B11
3,69	B5-B11	B5-B11	B5-B11	B5-B11	B5-B11
4,00	B5-B11	B5-B11	B5-B11	B5-B11	B5-B11
4,77	B5-B11	B5-B11	B5-B11	B5-B11	B5-B11
5,25	B5-B11	B5-B11	B5-B11	B5-B11	B5-B11
5,82	B5-B11	B5-B11	B5-B11	B5-B11	B5-B11
7,33	B5-B11	B5-B11	B5-B11		
8,38	B5-B11	B5-B11	B5-B11		

CH - H - PH 052					
i	071	080	090	100	112
5,73		B5-B11	B5-B11	B5-B11	B5-B11
6,89		B5-B11	B5-B11	B5-B11	B5-B11
8,53		B5-B11	B5-B11	B5-B11	B5-B11
9,56		B5-B11	B5-B11	B5-B11	B5-B11
11,51		B5-B11	B5-B11	B5-B11	B5-B11
14,24		B5-B11	B5-B11	B5-B11	B5-B11
16,59	B5-B11	B5-B11	B5-B11	B5-B11	B5-B11
18,00	B5-B11	B5-B11	B5-B11	B5-B11	B5-B11
19,97	B5-B11	B5-B11	B5-B11	B5-B11	B5-B11
21,67	B5-B11	B5-B11	B5-B11	B5-B11	B5-B11
24,71	B5-B11	B5-B11	B5-B11	B5-B11	B5-B11
26,18	B5-B11	B5-B11	B5-B11	B5-B11	B5-B11
28,44	B5-B11	B5-B11	B5-B11	B5-B11	B5-B11
31,52	B5-B11	B5-B11	B5-B11	B5-B11	B5-B11
33,00	B5-B11	B5-B11	B5-B11		
38,98	B5-B11	B5-B11	B5-B11	B5-B11	B5-B11
45,36	B5-B11	B5-B11	B5-B11		
49,13	B5-B11	B5-B11	B5-B11		
56,11	B5-B11	B5-B11	B5-B11		

CH - H - PH 053				
i	*063	071	080	090
58,81	B5-B11	B5-B11	B5-B11	B5-B11
72,75	B5-B11	B5-B11	B5-B11	B5-B11
90,51	B5-B11	B5-B11	B5-B11	B5-B11
108,95	B5-B11	B5-B11	B5-B11	B5-B11
134,76	B5-B11	B5-B11	B5-B11	B5-B11
157,29	B5-B11	B5-B11		
194,56	B5-B11	B5-B11		
216,38	B5-B11	B5-B11		
267,65	B5-B11	B5-B11		

CHR - HR - PHR 061				
i	080	090	100	112
1,34	B5-B11	B5-B11	B5-B11	B5-B11
2,13	B5-B11	B5-B11	B5-B11	B5-B11
2,57	B5-B11	B5-B11	B5-B11	B5-B11
3,17	B5-B11	B5-B11	B5-B11	B5-B11
3,69	B5-B11	B5-B11	B5-B11	B5-B11
4,00	B5-B11	B5-B11	B5-B11	B5-B11
4,77	B5-B11	B5-B11	B5-B11	B5-B11
5,25	B5-B11	B5-B11	B5-B11	B5-B11
5,82	B5-B11	B5-B11	B5-B11	B5-B11
7,33	B5-B11	B5-B11	B5-B11	B5-B11
8,38	B5-B11	B5-B11	B5-B11	B5-B11

CH - H - PH 062					
i	080	090	100	112	132
5,38	B5-B11	B5-B11	B5-B11	B5-B11	B5-B11
5,93	B5-B11	B5-B11	B5-B11	B5-B11	B5-B11
7,39	B5-B11	B5-B11	B5-B11	B5-B11	B5-B11
8,50	B5-B11	B5-B11	B5-B11	B5-B11	B5-B11
9,39	B5-B11	B5-B11	B5-B11	B5-B11	B5-B11
11,69	B5-B11	B5-B11	B5-B11	B5-B11	B5-B11
12,67	B5-B11	B5-B11	B5-B11	B5-B11	B5-B11
14,75	B5-B11	B5-B11	B5-B11	B5-B11	B5-B11
16,29	B5-B11	B5-B11	B5-B11	B5-B11	B5-B11
17,67	B5-B11	B5-B11	B5-B11	B5-B11	B5-B11
20,28	B5-B11	B5-B11	B5-B11	B5-B11	B5-B11
23,27	B5-B11	B5-B11	B5-B11	B5-B11	B5-B11
25,70	B5-B11	B5-B11	B5-B11	B5-B11	B5-B11
29,33	B5-B11	B5-B11	B5-B11	B5-B11	
32,00	B5-B11	B5-B11	B5-B11	B5-B11	B5-B11
36,99	B5-B11	B5-B11	B5-B11	B5-B11	
40,33	B5-B11	B5-B11	B5-B11	B5-B11	
46,06	B5-B11	B5-B11	B5-B11	B5-B11	

CH - H - PH 063					
i	071	080	090	100	112
49,45		B5-B11	B5-B11	B5-B11	B5-B11
54,61		B5-B11	B5-B11	B5-B11	B5-B11
68,00		B5-B11	B5-B11	B5-B11	B5-B11
85,82	B5-B11	B5-B11	B5-B11	B5-B11	B5-B11
94,76	B5-B11	B5-B11	B5-B11	B5-B11	B5-B11
118,00	B5-B11	B5-B11	B5-B11	B5-B11	B5-B11
135,40	B5-B11	B5-B11	B5-B11	B5-B11	B5-B11
149,51	B5-B11	B5-B11	B5-B11	B5-B11	B5-B11
170,67	B5-B11	B5-B11	B5-B11		
186,18	B5-B11	B5-B11	B5-B11	B5-B11	B5-B11
215,21	B5-B11	B5-B11	B5-B11		
234,67	B5-B11	B5-B11	B5-B11		
268,00	B5-B11	B5-B11	B5-B11		

2.6 MOTOR FLANGE AVAILABILITY

CHR - HR - PHR 081					
i	080	090	100	112	132
1,30					B5-B11
1,43					B5-B11
1,93					B5-B11
2,54			B5-B11	B5-B11	B5-B11
3,25			B5-B11	B5-B11	B5-B11
3,72			B5-B11	B5-B11	B5-B11
4,00			B5-B11	B5-B11	B5-B11
4,67			B5-B11	B5-B11	B5-B11
5,54	B5-B11	B5-B11	B5-B11	B5-B11	B5-B11
6,08	B5-B11	B5-B11	B5-B11	B5-B11	B5-B11
7,50	B5-B11	B5-B11	B5-B11	B5-B11	B5-B11
8,44	B5-B11	B5-B11	B5-B11	B5-B11	B5-B11

CH - H - PH 082						
i	080	090	100	112	132	160
5,39					B5-B11	B5
5,95					B5-B11	B5
7,39					B5-B11	B5
8,02					B5-B11	B5
8,85					B5-B11	B5
11,01					B5-B11	B5
13,50			B5-B11	B5-B11	B5-B11	B5
14,90			B5-B11	B5-B11	B5-B11	B5
16,60			B5-B11	B5-B11	B5-B11	B5
18,53			B5-B11	B5-B11	B5-B11	B5
19,38			B5-B11	B5-B11	B5-B11	B5
21,39			B5-B11	B5-B11	B5-B11	B5
22,80			B5-B11	B5-B11	B5-B11	B5
26,60			B5-B11	B5-B11	B5-B11	B5
27,88	B5-B11	B5-B11	B5-B11	B5-B11	B5-B11	
31,15	B5-B11	B5-B11	B5-B11	B5-B11	B5-B11	
34,38	B5-B11	B5-B11	B5-B11	B5-B11	B5-B11	
38,70	B5-B11	B5-B11	B5-B11	B5-B11	B5-B11	
42,75	B5-B11	B5-B11	B5-B11	B5-B11	B5-B11	
48,13	B5-B11	B5-B11	B5-B11	B5-B11	B5-B11	

CH - H - PH 083					
i	080	090	100	112	132
56,53	B5-B11	B5-B11	B5-B11	B5-B11	B5-B11
71,48	B5-B11	B5-B11	B5-B11	B5-B11	B5-B11
78,87	B5-B11	B5-B11	B5-B11	B5-B11	B5-B11
85,60	B5-B11	B5-B11	B5-B11	B5-B11	B5-B11
98,09	B5-B11	B5-B11	B5-B11	B5-B11	B5-B11
112,78	B5-B11	B5-B11	B5-B11	B5-B11	B5-B11
124,44	B5-B11	B5-B11	B5-B11	B5-B11	B5-B11
142,15	B5-B11	B5-B11	B5-B11	B5-B11	
154,76	B5-B11	B5-B11	B5-B11	B5-B11	B5-B11
162,35	B5-B11	B5-B11			
179,13	B5-B11	B5-B11			
195,07	B5-B11	B5-B11			
222,78	B5-B11	B5-B11			

CHR - HR - PHR 101					
i	100	112	132	160	180
1,29			B5-B11	B5	B5
1,41			B5-B11	B5	B5
2,03			B5-B11	B5	B5
2,48			B5-B11	B5	B5
3,27	B5-B11	B5-B11	B5-B11	B5	B5
3,70	B5-B11	B5-B11	B5-B11	B5	B5
4,22			B5-B11	B5	B5
4,88	B5-B11	B5-B11	B5-B11	B5	B5
5,27	B5-B11	B5-B11	B5-B11	B5	B5
6,23	B5-B11	B5-B11	B5-B11	B5	
7,55	B5-B11	B5-B11	B5-B11	B5	
8,40	B5-B11	B5-B11	B5-B11	B5	

CH - H - PH 102					
i	100	112	132	160	180
5,26			B5-B11	B5	B5
6,36			B5-B11	B5	B5
7,05			B5-B11	B5	B5
8,27			B5-B11	B5	B5
9,99			B5-B11	B5	B5
11,09			B5-B11	B5	B5
13,32	B5-B11	B5-B11	B5-B11	B5	B5
16,09	B5-B11	B5-B11	B5-B11	B5	B5
17,85	B5-B11	B5-B11	B5-B11	B5	B5
19,80	B5-B11	B5-B11	B5-B11	B5	B5
21,44	B5-B11	B5-B11	B5-B11	B5	B5
24,00	B5-B11	B5-B11	B5-B11	B5	B5
25,89	B5-B11	B5-B11	B5-B11	B5	B5
28,73	B5-B11	B5-B11	B5-B11	B5	B5
30,70	B5-B11	B5-B11	B5-B11	B5	
34,20	B5-B11	B5-B11	B5-B11	B5	
38,45	B5-B11	B5-B11	B5-B11		
41,30	B5-B11	B5-B11	B5-B11	B5	
45,82	B5-B11	B5-B11	B5-B11	B5	
51,52	B5-B11	B5-B11	B5-B11		

CH - H - PH 103					
i	090	100	112	132	160
55,47				B5-B11	B5
69,69		B5-B11	B5-B11	B5-B11	B5
79,80		B5-B11	B5-B11	B5-B11	B5
84,16		B5-B11	B5-B11	B5-B11	B5
93,36		B5-B11	B5-B11	B5-B11	B5
100,07		B5-B11	B5-B11	B5-B11	B5
120,84		B5-B11	B5-B11	B5-B11	B5
134,06		B5-B11	B5-B11	B5-B11	B5
143,40	B5-B11	B5-B11	B5-B11	B5-B11	
160,82	B5-B11	B5-B11	B5-B11	B5-B11	
181,07	B5-B11	B5-B11	B5-B11	B5-B11	
194,21	B5-B11	B5-B11	B5-B11	B5-B11	
215,45	B5-B11	B5-B11	B5-B11	B5-B11	
242,59	B5-B11	B5-B11	B5-B11	B5-B11	

2.6 MOTOR FLANGE AVAILABILITY

CHR - HR - PHR 121				
i	132	160	180	200
1,23		B5	B5	B5
1,42		B5	B5	B5
1,81		B5	B5	B5
2,00	B5-B11	B5	B5	B5
2,48	B5-B11	B5	B5	B5
2,95	B5-B11	B5	B5	B5
3,14	B5-B11	B5	B5	B5
3,58	B5-B11	B5	B5	B5
4,12	B5-B11	B5	B5	B5
4,80	B5-B11	B5	B5	B5
5,21	B5-B11	B5	B5	
6,25	B5-B11	B5	B5	
7,70	B5-B11	B5	B5	

CH - H - PH 122				
i	132	160	180	200
*5,27		B5	B5	B5
*5,78		B5	B5	B5
*7,05		B5	B5	B5
*7,74		B5	B5	B5
*8,48		B5	B5	B5
*10,35		B5	B5	B5
*12,66	B5-B11	B5	B5	B5
*13,86	B5-B11	B5	B5	B5
*16,92	B5-B11	B5	B5	B5
*19,30	B5-B11	B5	B5	B5
*20,57	B5-B11	B5	B5	B5
22,52	B5-B11	B5	B5	B5
24,47	B5-B11	B5	B5	B5
27,49	B5-B11	B5	B5	B5
29,86	B5-B11	B5	B5	
33,00	B5-B11	B5	B5	
36,13	B5-B11	B5	B5	
44,10	B5-B11	B5	B5	

CH - H - PH 123						
i	100	112	132	160	180	200
45,77			B5-B11	B5	B5	B5
55,87			B5-B11	B5	B5	B5
67,32	B5-B11	B5-B11	B5-B11	B5	B5	B5
73,71	B5-B11	B5-B11	B5-B11	B5	B5	B5
83,30	B5-B11	B5-B11	B5-B11	B5	B5	B5
89,97	B5-B11	B5-B11	B5-B11	B5	B5	B5
100,30	B5-B11	B5-B11	B5-B11	B5	B5	B5
108,34	B5-B11	B5-B11	B5-B11	B5	B5	B5
118,62	B5-B11	B5-B11	B5-B11	B5	B5	B5
128,18	B5-B11	B5-B11	B5-B11	B5	B5	
144,79	B5-B11	B5-B11	B5-B11	B5	B5	B5
155,22	B5-B11	B5-B11	B5-B11	B5	B5	
172,80	B5-B11	B5-B11	B5-B11	B5	B5	
189,19	B5-B11	B5-B11	B5-B11	B5	B5	
207,40	B5-B11	B5-B11	B5-B11	B5	B5	
230,92	B5-B11	B5-B11	B5-B11	B5	B5	
259,60	B5-B11	B5-B11	B5-B11			

CH - H - PH 142				
i	160	180	200	225
*5,27	B5	B5	B5	B5
*6,36	B5	B5	B5	B5
*7,04	B5	B5	B5	B5
*7,84	B5	B5	B5	B5
*9,45	B5	B5	B5	B5
*10,47	B5	B5	B5	B5
*13,07	B5	B5	B5	B5
*15,75	B5	B5	B5	B5
*17,45	B5	B5	B5	B5
*20,04	B5	B5	B5	B5
*24,15	B5	B5	B5	B5
*26,76	B5	B5	B5	B5
32,24	B5	B5	B5	B5
38,85	B5	B5	B5	B5
43,05	B5	B5	B5	B5

CH - H - PH 143				
i	132	160	180	200
48,35		B5	B5	B5
53,50	B5	B5	B5	B5
59,22	B5	B5	B5	B5
63,00	B5	B5	B5	B5
71,35	B5	B5	B5	B5
79,07	B5	B5	B5	B5
86,40	B5	B5	B5	B5
96,21	B5	B5	B5	B5
104,51	B5	B5	B5	
115,92	B5	B5	B5	B5
128,47	B5	B5	B5	B5
139,55	B5	B5	B5	
154,33	B5	B5	B5	
185,96	B5	B5	B5	
206,08	B5	B5	B5	

2.7 OUTPUT SHAFT BEARINGS

	HA30	HA40	HA50	HA60
	Standard	Standard	Standard	Standard
HA 1	1	1	1	1
HA 2/3	1	1	1	1

	HR041		HR051		HR061		HR081	HR101	HR121
	Standard	On request	Standard	On request	Standard	On request	Standard	Standard	Standard
HR 1/M	1	2	1	2	1	2	2	2	2

	H030	H040	H050	H060	H080	H100	H125	H140
	Standard	Standard	Standard	Standard	Standard	Standard	Standard	Standard
H 2/3	2	2	2	2	2	2	2	2

1 - Ball Bearing

2 - Roller bearings

/ - Not available

2.8.1 Information

The value of the admissible radial load [N] is given in the tables relating to the performance of the gear reducer at issue. It is related to the load applied on the centre line of the shaft and in the most unfavourable conditions of angle of application and direction of rotation. The maximum admissible axial loads are 1/5 of the value of the given radial load when they are applied in combination with the radial load. The tables relating to the output shafts give the maximum admissible value. This value must never be exceeded since it relates to the strength of the case. Particular conditions of radial load higher than the limits of the catalogue may occur. In this case, call our Technical Service and provide details on the application: direction of the load, direction of rotation of the shaft, type of service. The radial load on the shaft is calculated with the following formula: $Fr_e = (2000 * M * fz) / D \leq Fr1 \text{ or } Fr2$

- **Fr_e** [N] Resulting radial load
- **M** [Nm] Torque on the shaft
- **D** [mm] Diameter of the transmission member mounted on the shaft
- **Fr1-Fr2** [N] Value of the maximum admitted radial load (see relative tables)
- **fz** = 1,1 gear pinion - 1,4 chain wheel - 1,7 v-pulley - 2,5 flat pulley

2.8.2 Input

When the radial load is not on the centre line of the shaft, it is necessary to adjust the admissible radial load Fr1 with the following formula: $Fr_x = (Fr1 * a) / (b + x)$

- **a**, **b** = values given in the tables
- **x** = distance from the point of application of the load to the shaft shoulder

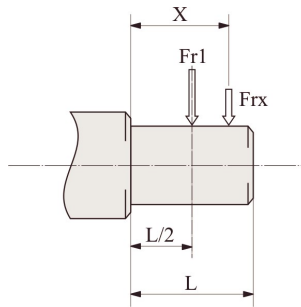

IH	A32/A33/A41/A42/A43/A51/A53/A63	A52/A61/A62
a	84	89
b	64	69
Fr1 max(**)	480	800

IHR	041	051	061	081	101	121
a	105	105	105	137	175	175
b	80	80	80	108	135	135
Fr1 max(**)	1320	1800	2200	2500	3000	3000

IH	032/033	042/043	052/053	062/063	082/083	102/103	122 123	142/143
a	105	105	105	137	137	175	175	225
b	80	80	80	108	108	135	135	170
Fr1 max(**)	2200	2200	2500	3600	3600	7200	7200	15000

(**Fr1 max) Max admissible value of the reducer in static conditions and/or for limited operations. For continuous overhung loads please check the values on the performances tables calculated according to the casing, the shaft and bearings.

2.8.3 Output

When the radial load is not on the centre line of the shaft, it is necessary to adjust the admissible radial load Fr2 with the following formula: $Fr_x = (Fr_2 \cdot a) / (b + x)$

- a , b = values given in the tables
- x = distance from the point of application of the load to the shaft shoulder

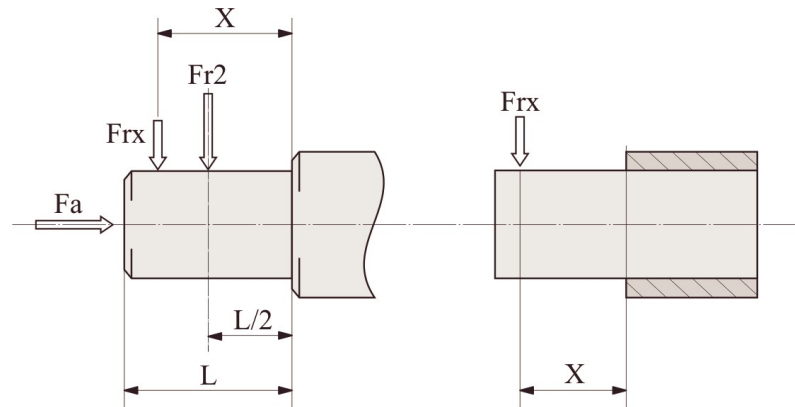

H	A31	A41	A51	A61	A32/A33	A42/A43	A52/A53	A62/A63
a	78,5	81	83	103	105	115	135	155
b	58,5	61	58	73	85	90	105	115
Fr2 max(**)	1100	1100	3000	4500	2000	4300	6000	8000

HR	041	051	061	081	101	121
a	89	98	115	151	210	232
b	79	73	85	111	155	177
Fr2 max(**)	1000	2500	3700	4000	5000	6000
Fa max(*)	5500	6500	7000	8500	11500	13500

H	032/033	042/043	052/053	062/063	082/083	102/103	122/123	142/143
a	120	138	169	195	238	281	331	367
b	96	108	134	155	188	221	261	282
Fr2 max(**)	5500	6600	8000	12000	18000	22000	30000	55000

(**Fr2 max) Max admissible value of the reducer in static conditions and/or for limited operations. For continuous overhung loads please check the values on the performances tables calculated according to the casing, the shaft and bearings.

(*Fa) Maximum permissible value of the gearbox with tapered roller bearings. Axial loads are not allowed with ball bearings. Sizes 041-051-061 in the STANDARD version are supplied with ball bearings.

2.9.1 Information

In cases of ambient temperatures not envisaged in the table, call our Technical Service. In the case of temperatures under -30°C or over 60°C it is necessary to use oil seals with special properties. For operating ranges with temperatures under 0°C it is necessary to consider the following:

1. The motors need to be suitable for operation at the envisaged ambient temperature.
2. The power of the electric motor needs to be adequate for exceeding the higher starting torques required.
3. In case of cast-iron gear reducers, pay attention to impact loads since cast iron may have problems of fragility at temperatures under -15°C .
4. During the early stages of service, problems of lubrication may arise due to the high level of viscosity taken on by the oil and so it is wise to have a few minutes of rotation under no load.



For ATEX gear reducers:

- Change oil as specified in the "Maintenance" table of the relevant "Use and Installation Instructions" manual (supplied with products).
- The use of oils other than the original one is forbidden.

2.9.2 Lubricants

Specifications of lubricants recommended by Motovario.

All units are supplied with ENI BLASIA 220 oil, unless otherwise specified by the client.

	HA32/3 ÷ A62/3 / HR041 ÷ 121 / H032/3 ÷ 142/3	
	Mineral oil	
T _{amb} °C ISO	(-5) ÷ (+40) ISO VG220	(-15) ÷ (+25) ISO VG150
ENI	BLASIA 220	BLASIA 150
SHELL	OMALA S2 G 220	OMALA S2 G 150
KLUBER	Kluberoil GEM 1-220N	Kluberoil GEM 1-150N
MOBIL	MOBILGEAR 600 XP220	MOBILGEAR 600 XP150
CASTROL	ALPHA SP 220	ALPHA SP 150
BP	ENERGOL GR-XP220	ENERGOL GR-XP150
PETRONAS	GEAR MEP 220	GEAR MEP 150

2.9.3 Special lubricants

	$T_{amb}^{\circ C}$	Polyglycol synthetic oil
ENI	(-30) ÷ (+30)	Blasia S 150 (ISO VG150)
	(-20) ÷ (+40)	Blasia S 220 (ISO VG220)
MOBIL	(-45) ÷ (+0)	SHC 624 (ISO VG32)
	(-40) ÷ (+5)	SHC 626 (ISO VG68)
KLUBER	(-40) ÷ (+5)	Klubersynth GH 6-32 (ISO VG32)
	(-35) ÷ 10)	Klubersynth GH 6-80 (ISO VG80)
	(-30) ÷ (+40)	Klubersynth GH 6-150 (ISO VG150)
	(-25) ÷ (+40)	Klubersynth GH 6-220 (ISO VG220)
	(-15) ÷ (+50)	Klubersynth GH 6-460 (ISO VG460)
	(-10) ÷ (+70)	Klubersynth GH 6-680 (ISO VG680)
	$T_{amb}^{\circ C}$	Polyglycol synthetic oil for food grade
KLUBER	(-30) ÷ (+15)	Klubersynth UH1-6 100 (ISO VG100)
	(-25) ÷ (+40)	Klubersynth UH1-6 220 (ISO VG220)
	(-15) ÷ (+40)	Klubersynth UH1-6 320 (ISO VG320)
	(-15) ÷ (+50)	Klubersynth UH1-6 460 (ISO VG460)
	(-10) ÷ (+50)	Klubersynth UH1-6 680 (ISO VG680)

If 'special' lubricant is required please contact MOTOVARIO TECHNICAL SERVICE.

2.9.4 Quantity

- For the gear reducer HA series with 2, 3 stages and for the reducers H series with 1, 2, 3 stages it is always necessary to specify the envisaged position.
- The gear reducer HA series with 1, 2, 3 stages all sizes, HR... series with 1 stage sizes 040, 050, 060 and H... series with 2, 3 stages sizes 030, 040, 050 are supplied complete with lubricant, have no oil plugs and need no maintenance.
- The gear reducer HR... series with 1 stage sizes 80,100,125 and H... series with 2, 3 stages sizes 060, 080, 100 are supplied complete with lubricant and are fitted with oil plugs to suit any mounting position included in the catalogue.
- The gear H... series with 2, 3 stages sizes 125, 140 have no lubricant and are fitted with oil plugs to suit any mounting position included in the catalogue. The oil filling can be done on request, in this case it is recommended, after installation, to replace the closed plug used for transportation with the supplied breather plug. When the reduction unit is supplied without lubricant, it is provided with a label to be filled.

Oil quantity in the table (litres ~) are indicative; for a proper use you will have to refer to the level plug or the dipstick. Any level difference could depend on construction tolerances, but also by the placement of the unit or by the mounting surface at the customer's premises. It is appropriate to check and, if necessary, restores the level when the units are installed.

H - CH	HA31	HA41	CHA41	A51	A61	A32	A42	A52	A62	A33	A43	A53	A63
B3-B5	0,07	0,23	0,13	0,25	0,62	0,68	0,7	1,2	1,9	1,1	1,16	1,9	2,4
B8													
B6-B7								1,6	2,1			2,5	3,1
V5-V1													
V6-V3													

HR - CHR	041	051	061	081	101	121	041M	051M	061M	081M	101M	121M
B3-B5	0,5	0,7	0,7	1,45	3,5	4,7	0,5	0,5	0,5	1,5	3,5	3,9
B5R	0,5	0,5	0,5	1,5	3,5	3,9	-	-	-	-	-	-
B8	0,5	0,5	0,5	1,5	3,5	3,9	0,5	0,7	0,7	1,45	3,5	4,7
B6-B7	0,5	0,7	0,7	1,5	3,5	4,1	0,5	0,7	0,7	1,5	3,5	4,1
V5-V1	0,5	0,7	0,9	1,5	3,5	4,7	0,5	0,7	0,9	1,5	3,5	4,7
V6-V3	0,5	0,7	0,7	1,5	3,5	4,1	0,5	0,7	0,7	1,5	3,5	4,1

H - CH	032/033	042/043	052/053	062/063	082/083	102/103	122/123	142/143
B3-B5	0,8	1,2	1,4	2,4	4,5	8,1	12,5	22,5
B8	0,85	1,2	1,4	3,1	5	8,9	12,5	20
B6-B7	1	1,2	1,8	3	4,6	8,4	12,1	22,5
V5-V1	1,3	1,75	2,15	3,9	7,6	12,7	20,5	30,5
V6-V3	1,2	1,7	2,1	4,4	7,5	14,2	21	38

2.10 MOMENTS OF INERTIA

The following values of J1 moment of inertia are only estimated, referred to the maximum calculated, and to the gearbox input side.

HA-1	J ₁ [Kg*m ²]
A31	0,0001
A41	0,0001
A51	0,0001
A61	0,0004

HR-1	J ₁ [Kg*m ²]
041	0,0001
051	0,0002
061	0,0005
081	0,0011
101	0,0035
121	0,0076

HA-2/3	J ₁ [Kg*m ²]
A32/A33	0,0001
A42/A43	0,0001
A52/A53	0,0003
A62/A63	0,0003

H-2/3	J ₁ [Kg*m ²]
032/033	0,0001
042/043	0,0001
052/053	0,0001
062/063	0,0002
082/083	0,0007
102/103	0,0010
122/123	0,0028
142/143	0,0044

3.1.1 HA31

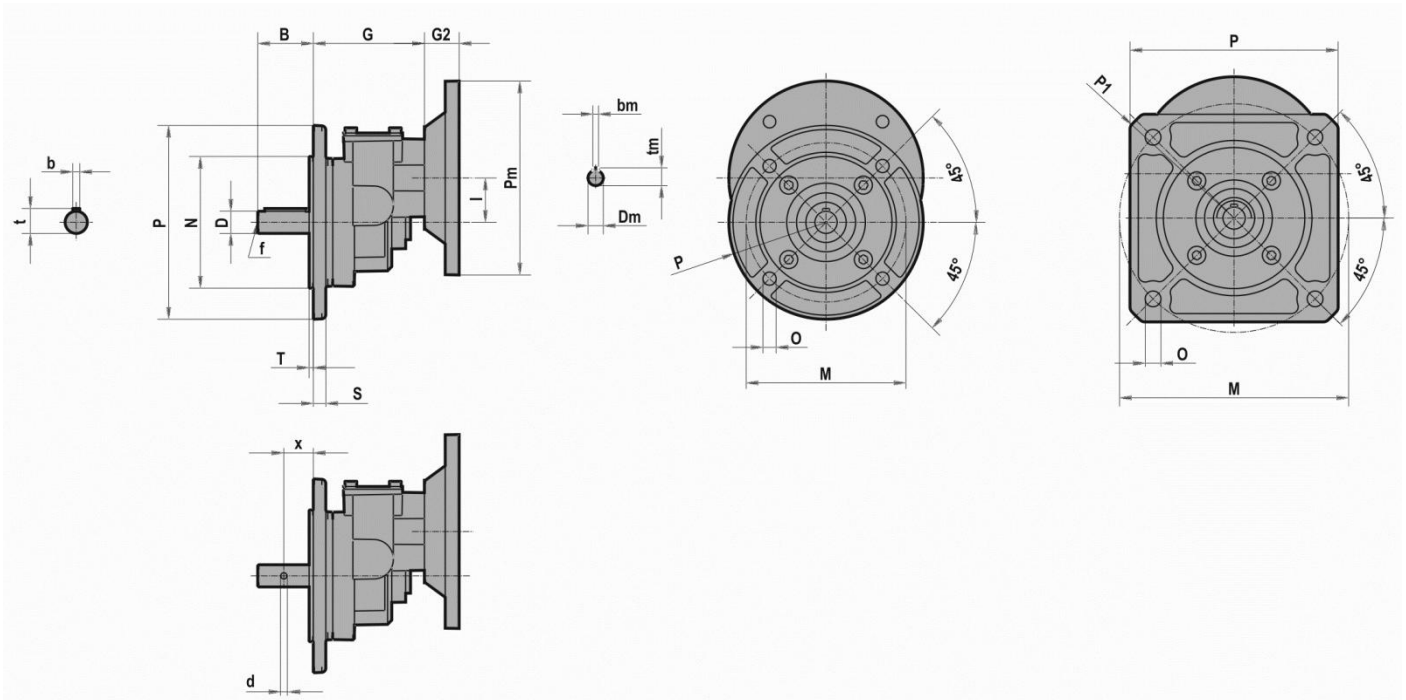

	D	B	b	t	x	d	f	G	I
HA31	11 j6	23	4	12,5	-	-	-	80	32
	14 j6	30	5	16	-	-	M6		
	16 j6	40	5	18	-	-	M6		
	19 j6	40	6	21,5	-	-	M6		
	16 j6	50	-	-	29	7	-		
	19 0/-0,2	60	-	-	37	6,5	-		
	19,7 +/- 0,05	100	-	-	50	6	M8		
	20 j6	75	-	-	45	6	-		

	P	P1	M	N	O	S	T
HA31	116	150	127	-	M8 (n.4)	-	-
	138	160	127	-	M8 (n.4)	-	-
	140	-	115	95 f7	9,5 (n.4)	9	3
	150	200	165	-	11 (n.4)	-	-

IEC	Pm x Dm	G2
063	140x11	25
071	160x14	32
080	200x19	42

B5	Pm	Dm	bm	tm
063	140	11	4	12,8
071	160	14	5	16,3
080	200	19	6	21,8

3.1.2 HA.1

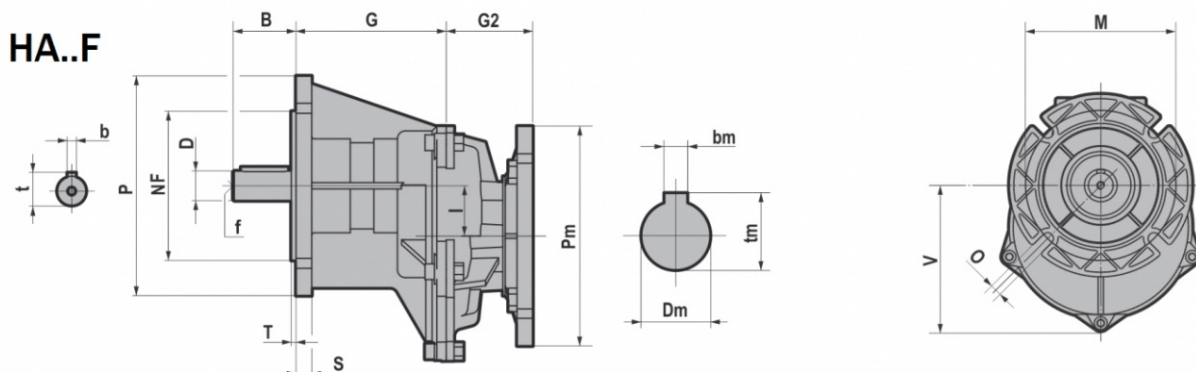
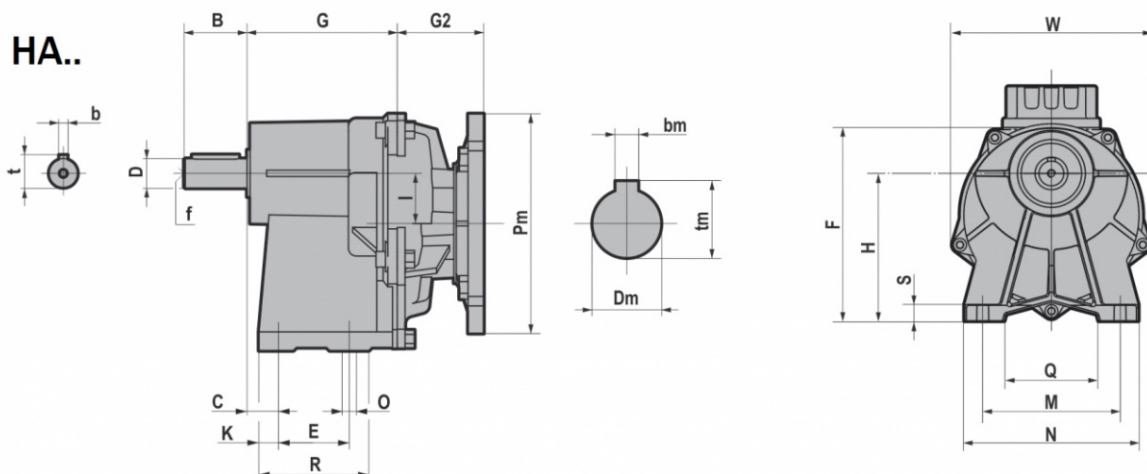

	D j6	B	C	E	F	G	H	I	K	M	N	O	Q	R	S	W	b	t	f
HA41/F	16	40	20	45	151	95,5	113	32	12,5	105	130	9	75	70	12	152	5	18	M6
	19																6	21,5	M6
HA51/F	24	50	6	70	169	104	130	32	15	150	180	11	115	100	12	152	8	27	M8
HA61/F	28	60	7,5	70	219,5	129	165	47,5	20	165	200	11	120	110	15	218	8	31	M8
	24	50															8	27	M8

	M	NF f8	O	P	S	T	V
HA41F	115	95	9 (n.4)	140	10	3	111,5
HA51F	130	110	9 (n.4)	160	10	3,5	111,5
HA61F	165	130	11 (n.4)	200	15	3,5	161,5

IEC	G2		HA41/F - HA51/F	HA61/F
	Pm x Dm	Pm x Dm		
063	140X11	090x11	55	/
071	160X14	105x14	55	/
080	200X19	120x19	86	87,5
090	200X24	140x24	86	87,5
100-112	250X28	160x28	/	87,5

B5	Pm	Dm	bm	tm
063	140	11	4	12,8
071	160	14	5	16,3
080	200	19	6	21,8
090	200	24	8	27,3
100	250	28	8	31,3
112	250	28	8	31,3

B14	Pm	Dm	bm	tm
071	105	14	5	16,3
080	120	19	6	21,8
090	140	24	8	27,3
100	160	28	8	31,3
112	160	28	8	31,3

3.1.3 CHA.1

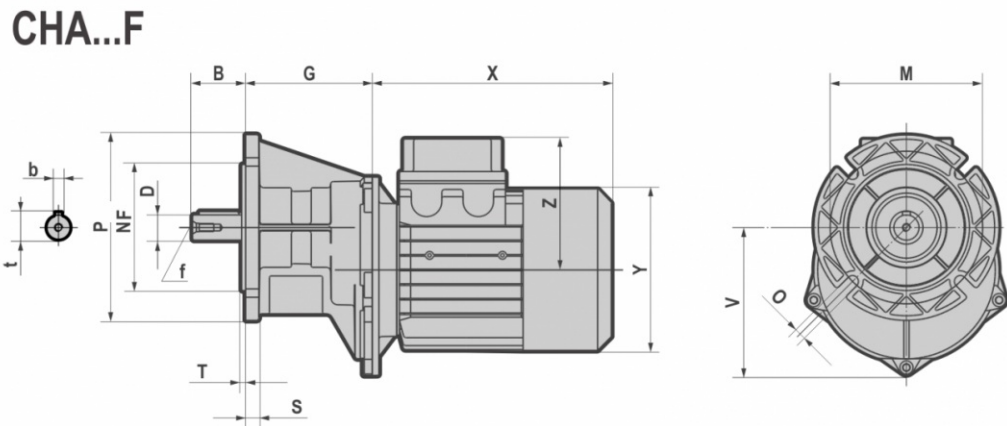
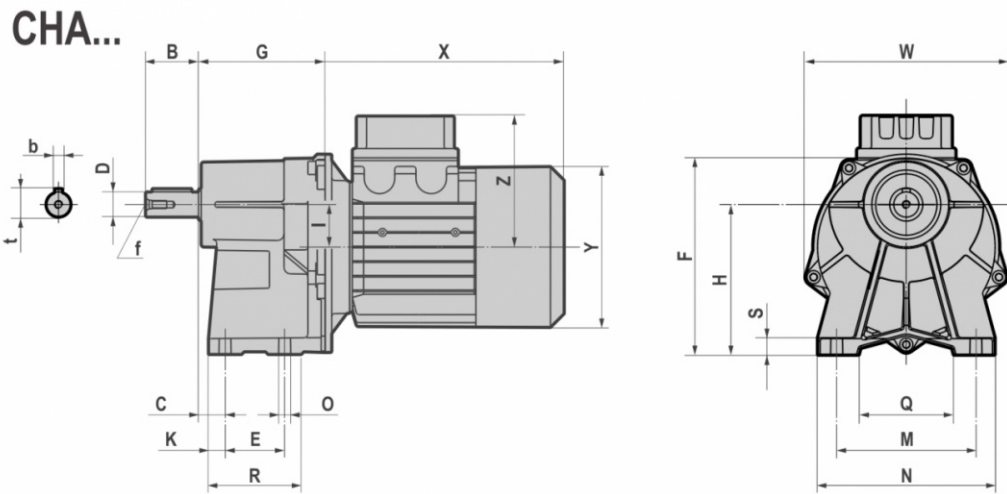

	D j6	B	C	E	F	G	H	I	K	M	N	O	Q	R	S	W	b	t	f
CHA41/F	16	40	20	45	151	95,5	113	32	12,5	105	130	9	75	70	12	152	5	18	M6
	19																6	21,5	M6
CHA51/F	24	50	6	70	169	104	130	32	15	150	180	11	115	100	12	152	8	27	M8
CHA61/F	28	60	7,5	70	219,5	129	165	47,5	20	165	200	11	120	110	15	218	8	31	M8
	24	50															8	27	M8

	M	NF f8	O	P	S	T	V
CHA41F	115	95	9 (n.4)	140	10	3	111,5
CHA51F	130	110	9 (n.4)	160	10	3,5	111,5
CHA61F	165	130	11 (n.4)	200	15	3,5	161,5

		T (IE1 - IE2 - IE3)						
		063	071	080	090S	090L	100	112
CHA41/F CHA51/F	X	180	205	223 *(246)	232 *(265)	257 *(290)	/	/
	Y	121	139	158	173	173	/	/
	Z	104	112	122	130	130	/	/
CHA61/F	X	/	/	218 *(241)	232 *(265)	257 *(290)	290	302 *(326)
	Y	/	/	158	173	173	191	211
	Z	/	/	122	130	130	139	154

		TB (IE1 - IE2 - IE3)						
		063	071	080	090S	090L	100	112
CHA41/F CHA51/F	X	238	271	294 *(317)	309 *(342)	334 *(367)	/	/
	Y	121	139	158	173	173	/	/
	Z	119	129	137	157	157	/	/
CHA61/F	X	/	/	290 *(313)	309 *(342)	334 *(367)	372	400 *(424)
	Y	/	/	158	173	173	191	211
	Z	/	/	137	157	157	230	230

*TP80B4, TP90S4, TP90L4, TP90S6, TP112M4, TP112M6

3.1.4 IHA.1

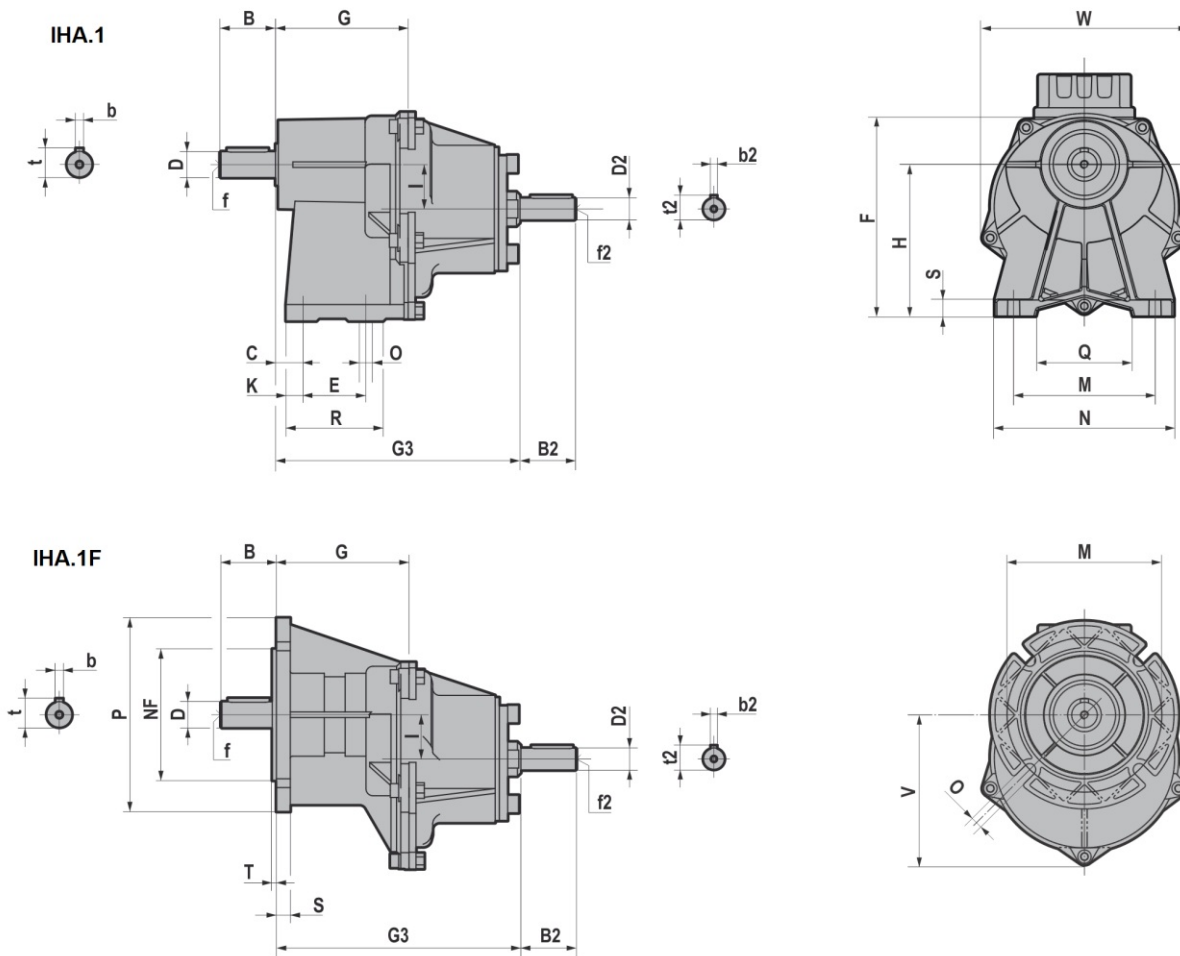

	D j6	B	C	E	F	G	H	I	K	M	N	O	Q	R	S	W	b	t	f
IHA41/F	16																5	18	M6
	19	40	20	45	151	95,5	113	32	12,5	105	130	9	75	70	12	152	6	21,5	M6
IHA51/F	24	50	6	70	169	104	130	32	15	150	180	11	115	100	12	152	8	27	M8
IHA61/F	28	60		70	219,5	129	165	47,5	20	165	200	11	120	110	15	218	8	31	M8
	24	50	7,5	70	219,5	129	165	47,5	20	165	200	11	120	110	15	218	8	27	M8

	M	NF f8	O	P	S	T	V
IHA41F	115	95	9 (n.4)	140	10	3	111,5
IHA51F	130	110	9 (n.4)	160	10	3,5	111,5
IHA61F	165	130	11 (n.4)	200	15	3,5	161,5

	G3	D2 j6	B2	b2	f2	t2
IHA41/F	176	16	40	5	M6	18
IHA51/F	184,5	16	40	5	M6	18
IHA61/F	209	19	40	6	M6	21,5

3.1.5 HA.2

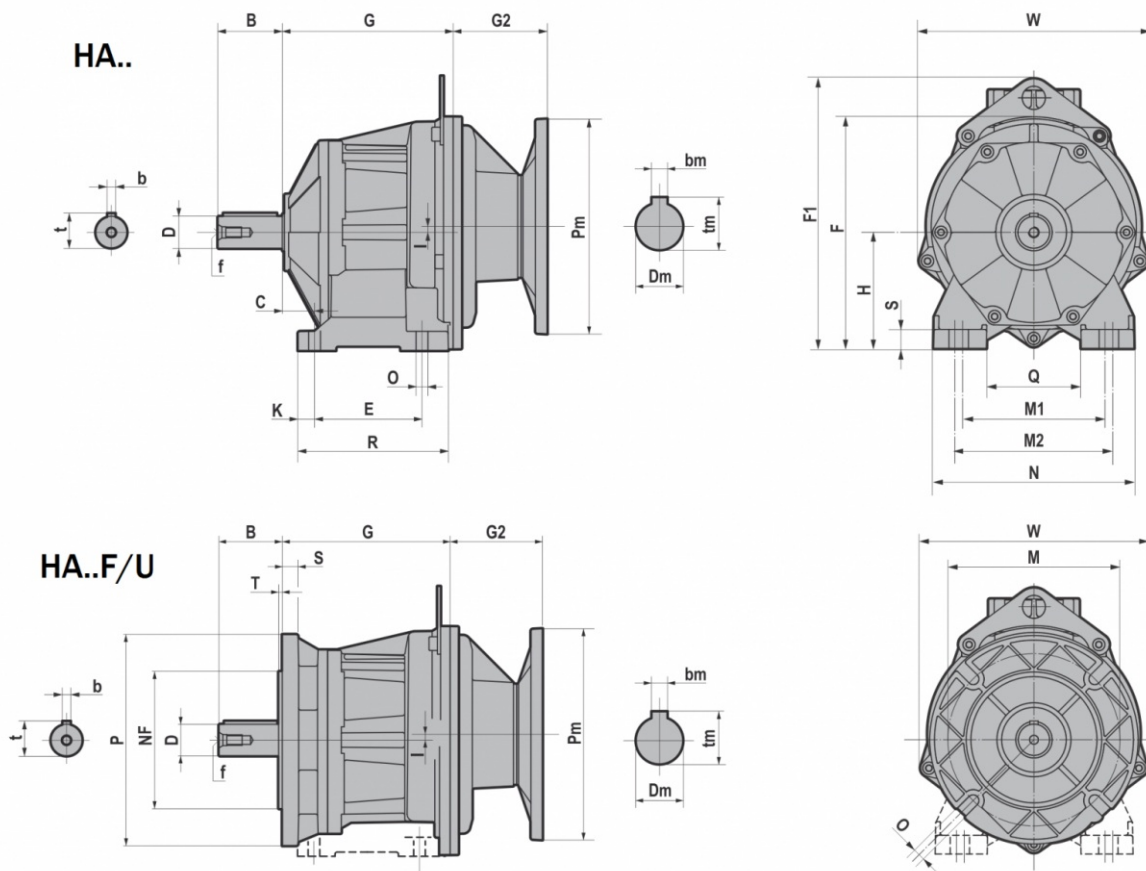

HA../F/U	D j6	B	b	t	f	C	E	F	F1	G	H	I	K	M1	M2	N	O	Q	R	S	W
HA32	20	40	6	22,5	M6	18	80	155	/	117,5	75	10	13	110	120	145	9	75	111	15	152
	19	40	6	21,5	M6																
	16	40	5	18	M6																
	14	30	5	16	M6																
HA42	25	50	8	28	M10	25	85	160	/	124,5	80	10	13	110	120	145	9	75	111	15	152
	28	60	8	31	M10																
	24	50	8	27	M8																
	22	50	6	24,5	M8																
	20	40	6	22,5	M6																
HA52	19	40	6	21,5	M6	30	100	217,5	255,5	159	110	5,5	15,5	135	150	190	11	90	140	18	218
	30	60	8	33	M10																
	35	70	10	38	M12																
	32	60	10	35	M10																
	28	60	8	31	M10																
	25	50	8	28	M10																
HA62	24	50	8	27	M8	35	110	237,5	275,5	168	120	15,5	20	170	185	230	14	120	150	20	218
	40	80	12	43	M16																
	35 k6	70	10	38	M12																
	30	60	8	33	M10																
	28	60	8	31	M10																

	P	M	NF f8	O	G	I	S	T	W
HA32F/U	140	115	95	9 (n.4)	117,5	10	10	3	152
	120	100	80						
HA42F/U	160	130	110	9 (n.4)	124,5	10	10	3,5	152

3.1 REDUCERS/GEARED MOTORS

	140	115	95						
HA52F/U	200	165	130	11 (n.4)	159	5,5	15	3,5	218
	160	130	110						
HA62F/U	250	215	180	14 (n.4)	168	15,5	15	4	218
	200	165	130						

IEC	Pm x Dm	Pm x Dm	G2	
			HA32/F/U - HA42/F/U	HA52/F/U - HA62/F/U
063	140X11	090x11	55,0	/
071	160X14	105x14	55,0	/
080	200X19	120x19	86,0	87,5
090	200X24	140x24	86,0	87,5
100-112	250X28	160x28	/	87,5

B5	Pm	Dm	bm	tm
063	140	11	4	12,8
071	160	14	5	16,3
080	200	19	6	21,8
090	200	24	8	27,3
100	250	28	8	31,3
112	250	28	8	31,3

B14	Pm	Dm	bm	tm
071	105	14	5	16,3
080	120	19	6	21,8
090	140	24	8	27,3
100	160	28	8	31,3
112	160	28	8	31,3

3.1.6 CHA.2

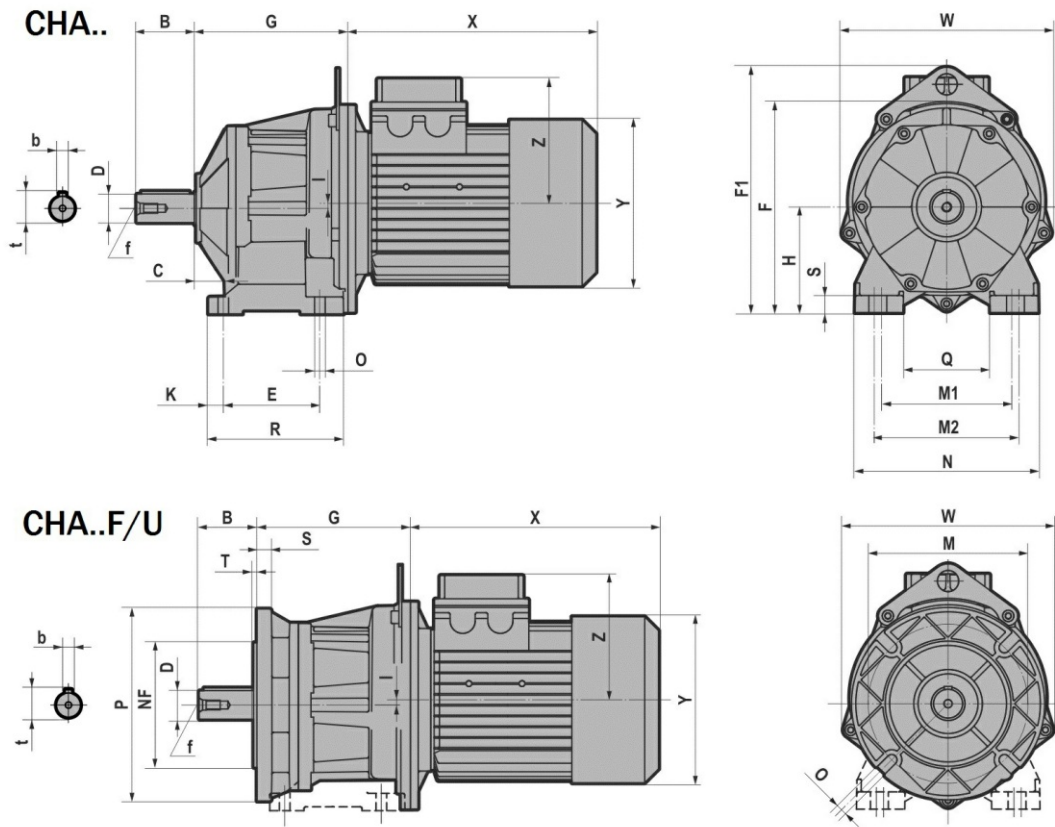

CHA../F/U	D j6	B	b	t	f	C	E	F	F1	G	H	I	K	M1	M2	N	O	Q	R	S	W
CHA32	20	40	6	22,5	M6	18	80	155	/	117,5	75	10	13	110	120	145	9	75	111	15	152
	19	40	6	21,5	M6																
	16	40	5	18	M6																
	14	30	5	16	M6																
CHA42	25	50	8	28	M10	25	85	160	/	124,5	80	10	13	110	120	145	9	75	111	15	152
	28	60	8	31	M10																
	24	50	8	27	M8																
	22	50	6	24,5	M8																
	20	40	6	22,5	M6																
CHA52	30	60	8	33	M10	30	100	217,5	255,5	159	110	5,5	15,5	135	150	190	11	90	140	18	218
	35	70	10	38	M12																
	32	60	10	35	M10																
	28	60	8	31	M10																
	25	50	8	28	M10																
	24	50	8	27	M8																
CHA62	40	80	12	43	M16	35	110	237,5	275,5	168	120	15,5	20	170	185	230	14	120	150	20	218
	35 k6	70	10	38	M12																
	30	60	8	33	M10																
	28	60	8	31	M10																

	P	M	NF f8	O	G	I	S	T	W
CHA32F/U	140	115	95	9 (n.4)	117,5	10	10	3	152
	120	100	80						
CHA42F/U	160	130	110	9 (n.4)	124,5	10	10	3,5	152
	140	115	95						
CHA52F/U	200	165	130	11 (n.4)	159	5,5	15	3,5	218

3.1 REDUCERS/GEARED MOTORS

	160	130	110						
CHA62F/U	250	215	180	14 (n.4)	168	15,5	15	4	218
	200	165	130						

T (IE1 - IE2 - IE3)								
CHA..F/U		063	071	080	090S	090L	100	112
CHA32 CHA42	X	180	205	223 *(246)	232 *(265)	257 *(290)	/	/
	Y	121	139	158	173	173	/	/
	Z	104	112	122	130	130	/	/
CHA52 CHA62	X	/	/	218 *(241)	232 *(265)	257 *(290)	290	302 *(326)
	Y	/	/	158	173	173	191	211
	Z	/	/	122	130	130	139	154

TB (IE1 - IE2 - IE3)								
CHA..F/U		063	071	080	090S	090L	100	112
CHA32 CHA42	X	238	271	294 *(317)	309 *(342)	334 *(367)	/	/
	Y	121	139	158	173	173	/	/
	Z	119	129	137	157	157	/	/
CHA52 CHA62	X	/	/	290 *(313)	309 *(342)	334 *(367)	372	400 *(424)
	Y	/	/	158	173	173	191	211
	Z	/	/	137	157	157	230	230

*TP80B4, TP90S4, TP90L4, TP90S6, TP112M4, TP112M6

3.1.7 IHA.2

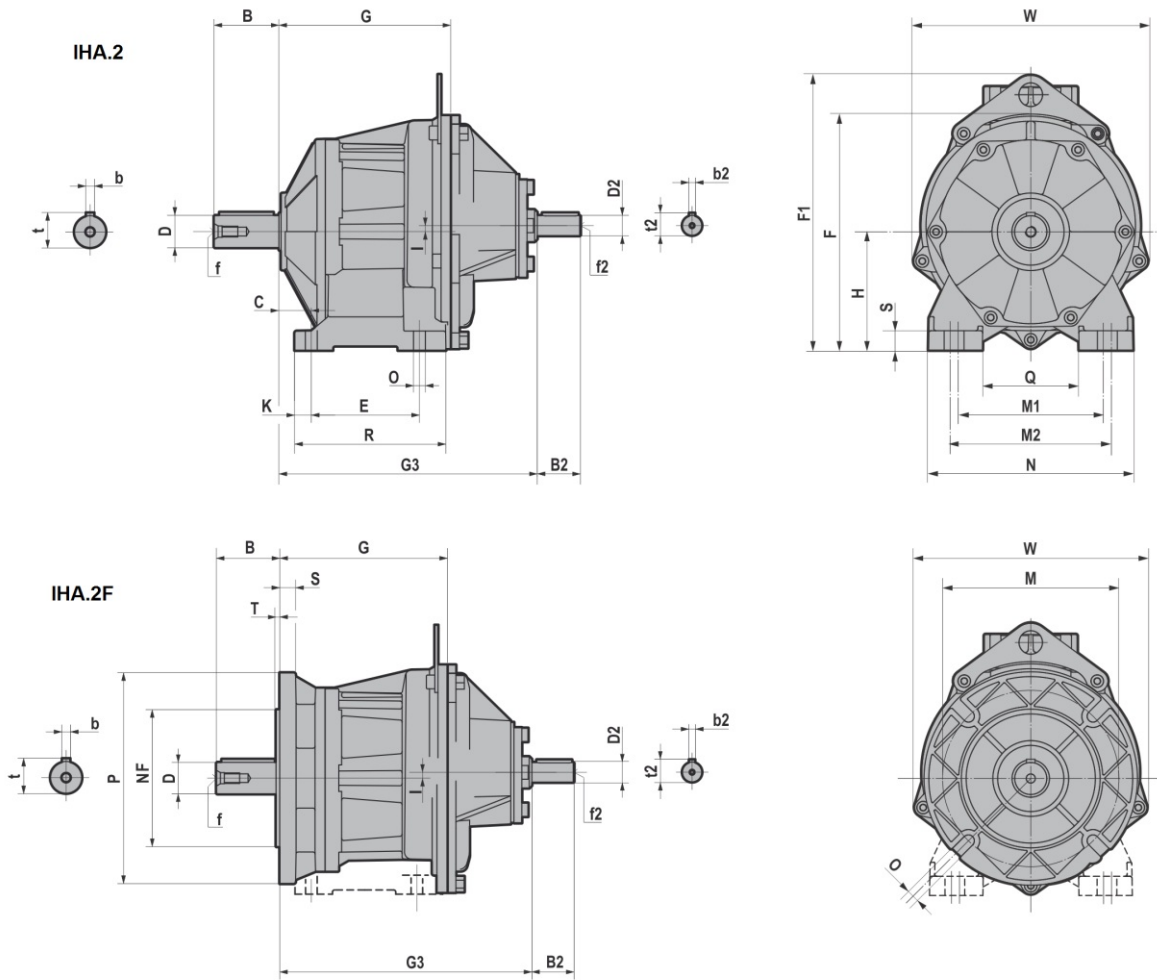

IHA.../F/U	Dj6	B	b	t	f	C	E	F	F1	G	H	I	K	M1	M2	N	O	Q	R	S	W
IHA32	20	40	6	22,5	M6	18	80	155	/	117,5	75	10	13	110	120	145	9	75	111	15	152
	19	40	6	21,5	M6																
	16	40	5	18	M6																
	14	30	5	16	M6																
IHA42	25	50	8	28	M10	25	85	160	/	124,5	80	10	13	110	120	145	9	75	111	15	152
	28	60	8	31	M10																
	24	50	8	27	M8																
	22	50	6	24,5	M8																
	20	40	6	22,5	M6																
IHA52	19	40	6	21,5	M6	30	100	217,5	255,5	159	110	5,5	15,5	135	150	190	11	90	140	18	218
	30	60	8	33	M10																
	35	70	10	38	M12																
	32	60	10	35	M10																
	28	60	8	31	M10																
	25	50	8	28	M10																
IHA62	24	50	8	27	M8	35	110	237,5	275,5	168	120	15,5	20	170	185	230	14	120	150	20	218
	40	80	12	43	M16																
	35 k6	70	10	38	M12																
	30	60	8	33	M10																
	28	60	8	31	M10																

P	M	NF f8	O	G	I	S	T	W
---	---	-------	---	---	---	---	---	---

3.1 REDUCERS/GEARED MOTORS

IHA32F/U	140	115	95	9 (n.4)	117,5	10	10	3	152
	120	100	80						
IHA42F/U	160	130	110	9 (n.4)	124,5	10	10	3,5	152
	140	115	95						
IHA52F/U	200	165	130	11 (n.4)	159	5,5	15	3,5	218
	160	130	110						
IHA62F/U	250	215	180	14 (n.4)	168	15,5	15	4	218
	200	165	130						

	G3	D2 j6	B2	b2	f2	t2
IHA32/F/U	198	16	40	5	M6	18
IHA42/F/U	205	16	40	5	M6	18
IHA52/F/U	239	19	40	6	M6	21,5
IHA62/F/U	248	19	40	6	M6	21,5

3.1.8 HA.3

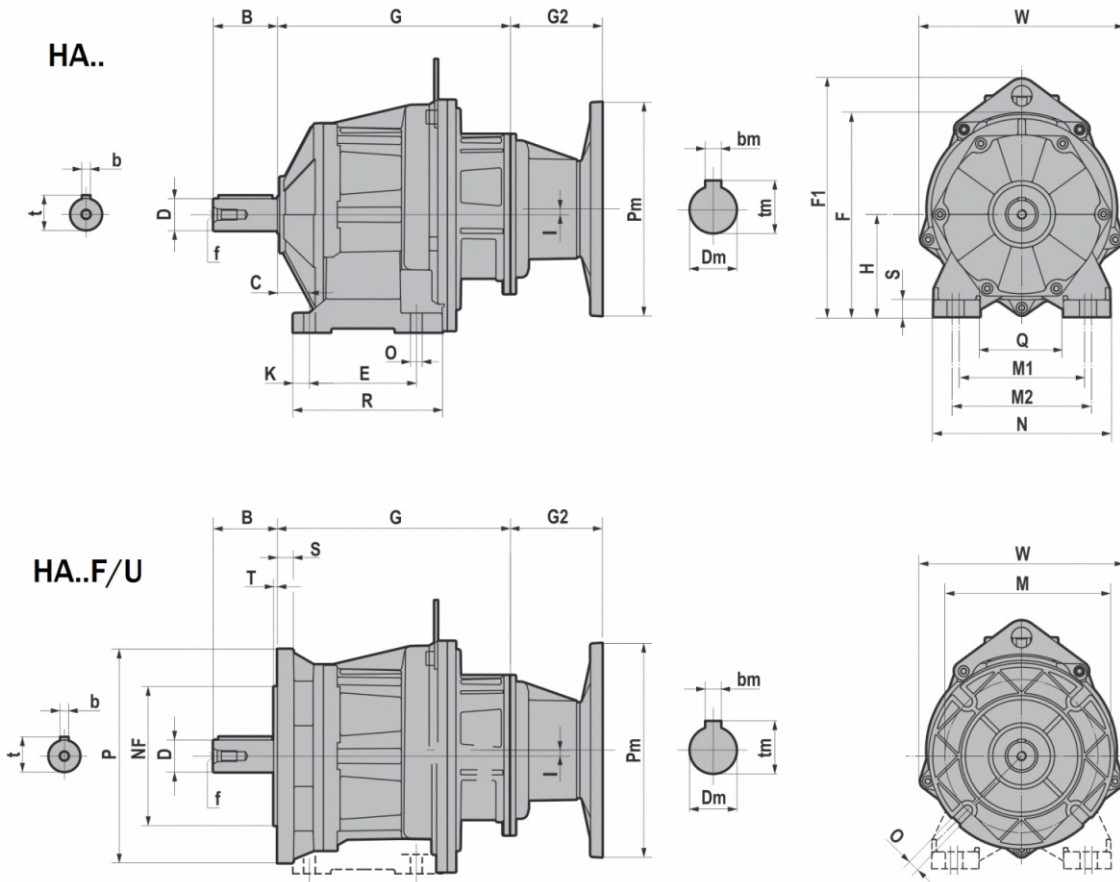

HA..F/U	D j6	B	b	t	f	C	E	F	F1	G	H	I	K	M1	M2	N	O	Q	R	S	W
HA33	20	40	6	22,5	M6	18	80	155	/	117,5	75	10	13	110	120	145	9	75	111	15	152
	19	40	6	21,5	M6																
	16	40	5	18	M6																
	14	30	5	16	M6																
HA43	25	50	8	28	M10	25	85	160	/	124,5	80	10	13	110	120	145	9	75	111	15	152
	28	60	8	31	M10																
	24	50	8	27	M8																
	22	50	6	24,5	M8																
	20	40	6	22,5	M6																
HA53	19	40	6	21,5	M6	30	100	217,5	255,5	159	110	5,5	15,5	135	150	190	11	90	140	18	218
	30	60	8	33	M10																
	35	70	10	38	M12																
	32	60	10	35	M10																
	28	60	8	31	M10																
	25	50	8	28	M10																
HA63	24	50	8	27	M8	35	110	237,5	275,5	168	120	15,5	20	170	185	230	14	120	150	20	218
	40	80	12	43	M16																
	35 k6	70	10	38	M12																
	30	60	8	33	M10																
	28	60	8	31	M10																

3.1 REDUCERS/GEARED MOTORS

	P	M	NF f8	O	G	I	S	T	W
HA33F/U	140	115	95	9 (n.4)	117,5	10	10	3	152
	120	100	80						
HA43F/U	160	130	110	9 (n.4)	124,5	10	10	3,5	152
	140	115	95						
HA53F/U	200	165	130	11 (n.4)	159	5,5	15	3,5	218
	160	130	110						
HA63F/U	250	215	180	14 (n.4)	168	15,5	15	4	218
	200	165	130						

			G2
IEC	Pm x Dm	Pm x Dm	HA33/F/U - HA43/F/U - HA53/F/U - HA63/F/U
063	140X11	090x11	55
071	160X14	105x14	55
080	200X19	120x19	86
090	200X24	140x24	86

B5	Pm	Dm	bm	tm
063	140	11	4	12,8
071	160	14	5	16,3
080	200	19	6	21,8
090	200	24	8	27,3

B14	Pm	Dm	bm	tm
071	105	14	5	16,3
080	120	19	6	21,8
090	140	24	8	27,3

3.1.9 CHA.3

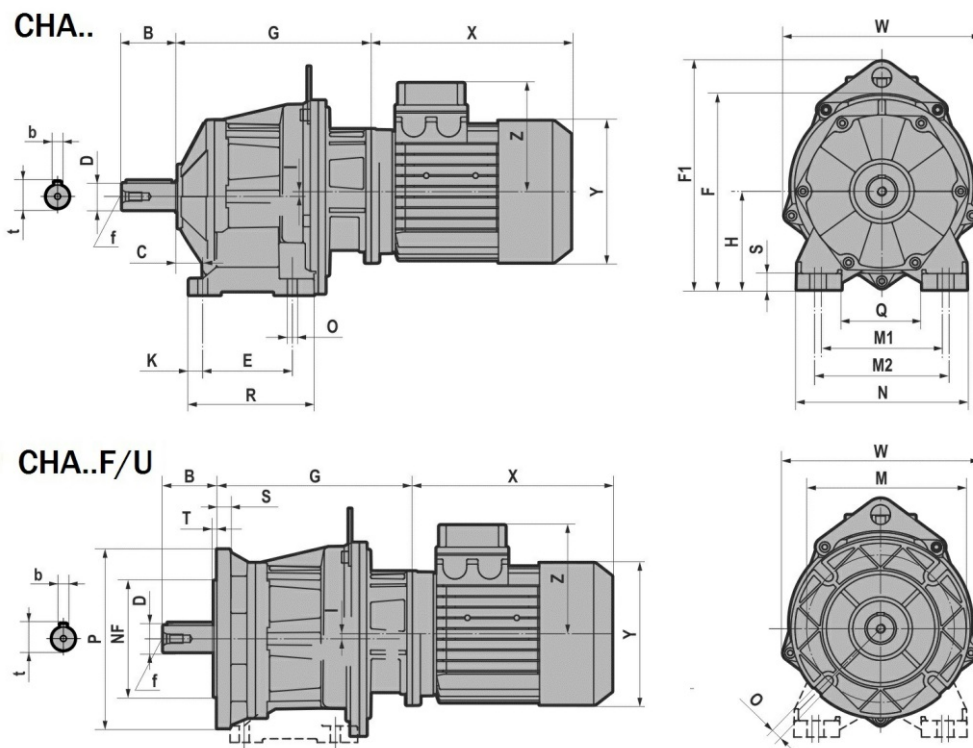

CHA..F/U	D j6	B	b	t	f	C	E	F	F1	G	H	I	K	M1	M2	N	O	Q	R	S	W
CHA33	20	40	6	22,5	M6	18	80	155	/	117,5	75	10	13	110	120	145	9	75	111	15	152
	19	40	6	21,5	M6																
	16	40	5	18	M6																
	14	30	5	16	M6																
CHA43	25	50	8	28	M10	25	85	160	/	124,5	80	10	13	110	120	145	9	75	111	15	152
	28	60	8	31	M10																
	24	50	8	27	M8																
	22	50	6	24,5	M8																
	20	40	6	22,5	M6																
	19	40	6	21,5	M6																
CHA53	30	60	8	33	M10	30	100	217,5	255,5	159	110	5,5	15,5	135	150	190	11	90	140	18	218
	35	70	10	38	M12																
	32	60	10	35	M10																
	28	60	8	31	M10																
	25	50	8	28	M10																
	24	50	8	27	M8																
CHA63	40	80	12	43	M16	35	110	237,5	275,5	168	120	15,5	20	170	185	230	14	120	150	20	218
	35 k6	70	10	38	M12																
	30	60	8	33	M10																
	28	60	8	31	M10																

	P	M	NF f8	O	G	I	S	T	W
CHA33F/U	140	115	95	9 (n.4)	117,5	10	10	3	152
	120	100	80						
CHA43F/U	160	130	110	9 (n.4)	124,5	10	10	3,5	152
	140	115	95						
CHA53F/U	200	165	130	11 (n.4)	159	5,5	15	3,5	218
	160	130	110						
CHA63F/U	250	215	180	14 (n.4)	168	15,5	15	4	218
	200	165	130						

3.1 REDUCERS/GEARED MOTORS

T (IE1 - IE2 - IE3)						
CHA..F/U		063	071	080	090S	090L
CHA33 CHA43 CHA53 CHA63	X	180	205	223 *(246)	232 *(265)	257 *(290)
	Y	121	139	158	173	173
	Z	104	112	122	130	130

TB (IE1 - IE2 - IE3)						
CHA..F/U		063	071	080	090S	090L
CHA33 CHA43 CHA53 CHA63	X	238	271	294 *(317)	309 *(342)	334 *(367)
	Y	121	139	158	173	173
	Z	119	129	137	157	157

*TP80B4, TP90S4, TP90L4, TP90S6, TP112M4, TP112M6

3.1.10 IHA.3

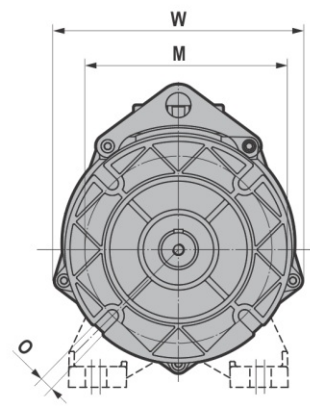
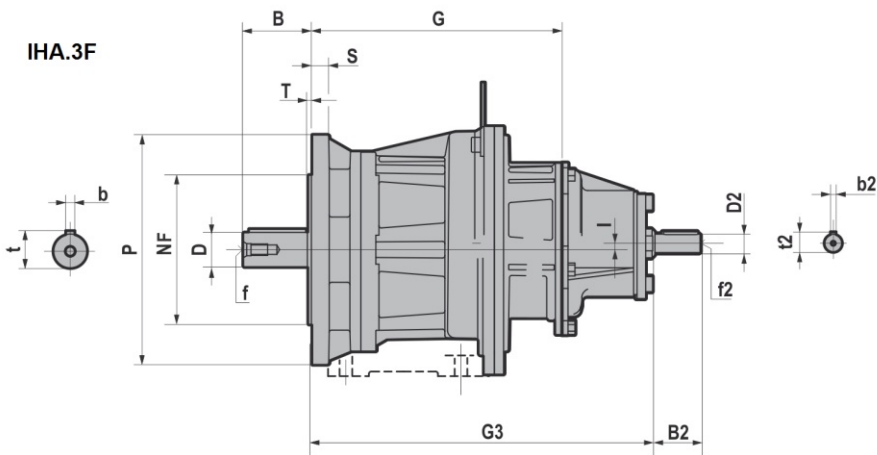
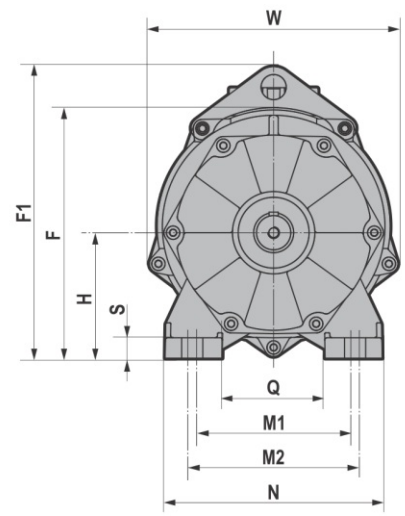
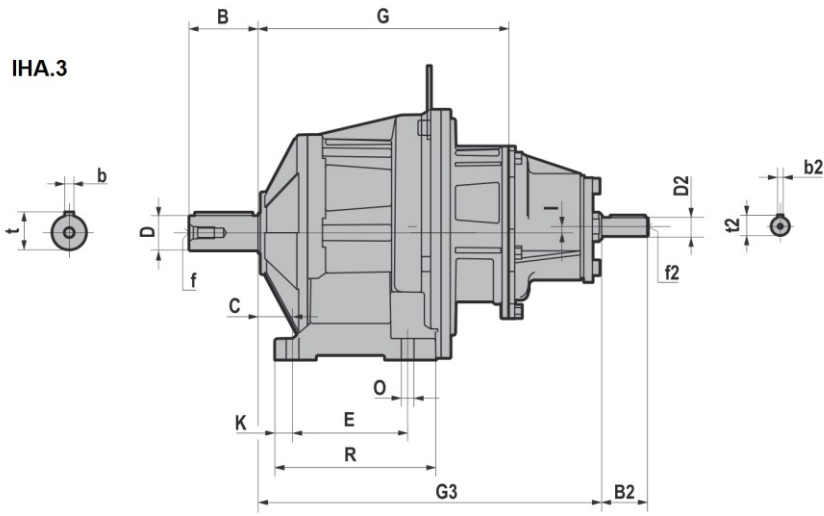

3.1 REDUCERS/GEARED MOTORS

IHA..F/U	D j6	B	b	t	f	C	E	F	F1	G	H	I	K	M1	M2	N	O	Q	R	S	W
IHA33	20	40	6	22,5	M6	18	80	155	/	117,5	75	10	13	110	120	145	9	75	111	15	152
	19	40	6	21,5	M6																
	16	40	5	18	M6																
	14	30	5	16	M6																
IHA43	25	50	8	28	M10	25	85	160	/	124,5	80	10	13	110	120	145	9	75	111	15	152
	28	60	8	31	M10																
	24	50	8	27	M8																
	22	50	6	24,5	M8																
	20	40	6	22,5	M6																
	19	40	6	21,5	M6																
IHA53	30	60	8	33	M10	30	100	217,5	255,5	159	110	5,5	15,5	135	150	190	11	90	140	18	218
	35	70	10	38	M12																
	32	60	10	35	M10																
	28	60	8	31	M10																
	25	50	8	28	M10																
	24	50	8	27	M8																
IHA63	40	80	12	43	M16	35	110	237,5	275,5	168	120	15,5	20	170	185	230	14	120	150	20	218
	35 k6	70	10	38	M12																
	30	60	8	33	M10																
	28	60	8	31	M10																

	P	M	NF f8	O	G	I	S	T	W
IHA33F/U	140	115	95	9 (n.4)	117,5	10	10	3	152
	120	100	80						
IHA43F/U	160	130	110	9 (n.4)	124,5	10	10	3,5	152
	140	115	95						
IHA53F/U	200	165	130	11 (n.4)	159	5,5	15	3,5	218
	160	130	110						
IHA63F/U	250	215	180	14 (n.4)	168	15,5	15	4	218
	200	165	130						

	G3	D2 j6	B2	b2	f2	t2
IHA33	251	16	40	5	M6	18
IHA43	258	16	40	5	M6	18
IHA53	299	16	40	5	M6	18
IHA63	308	16	40	5	M6	18

3.1.11 HR.1

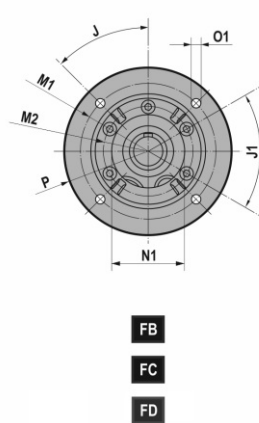
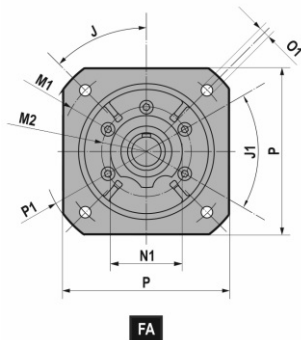
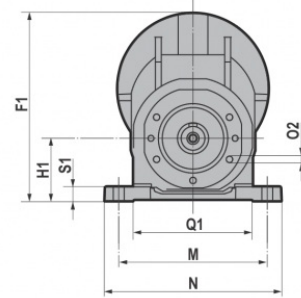
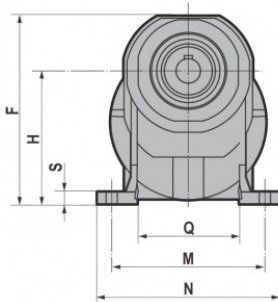
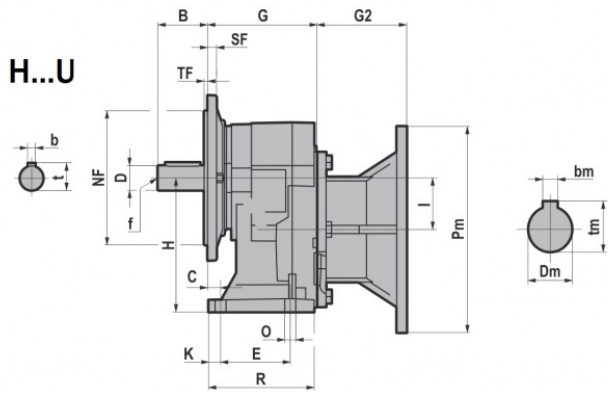
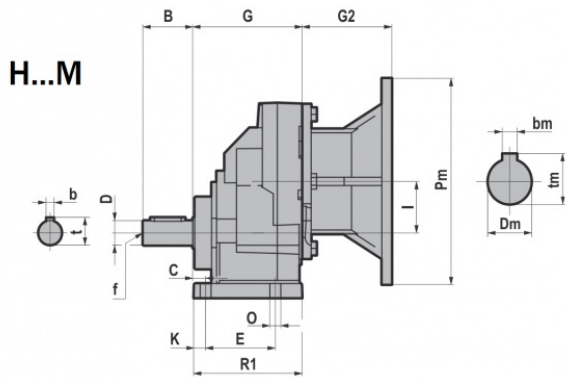
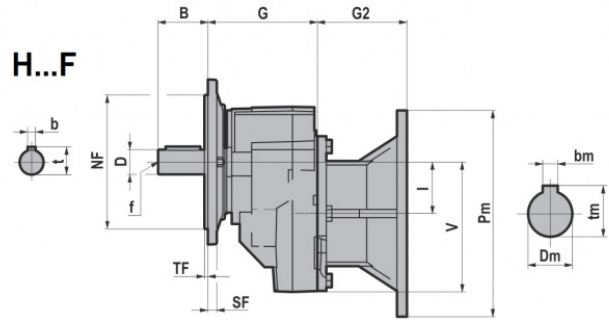
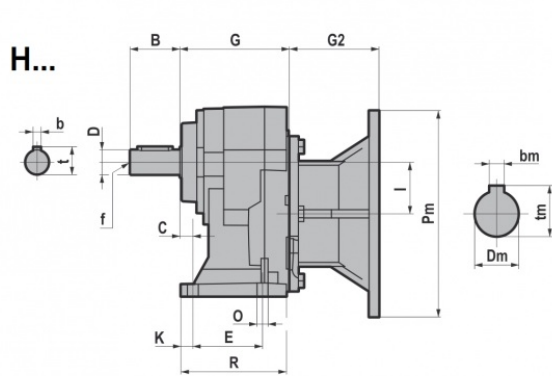

FA

FB

FC

FD

3.1 REDUCERS/GEARED MOTORS

HR.../F/U/M	D	B	C	E	F	F1	G	H	H1	I	K	M	N	O	O2	Q	Q1	R	R1	S	S1	-V	b	t	f
HR041	19 j6	40	13	45	168,5	168	100	120	50	42	12	105	130 125 (041M)	9	M8x17 (n.5)	74	55	86,5	98	9,5	8	118	6	21,5	M6
HR051	24 j6	50	13	70	183,5	189	110	130	63	50	12	150	178	11	M8x17 (n.5)	100	121,5	106	109	11,5	14	126	8	27	M8
HR061	28 j6	60	16	70	231	216	125	165	80	60	14	165	195	11	M8x17 (n.5)	110	135,5	120	123	15	16	136	8	31	M10
HR081	38 k6	80	25	85	277	284	135	195	100	80	23	185	230 232 (081M)	14	M10x20 (n.7)	123	151	130	135	15	20	184	10	41	M12
HR101	48 k6	110	19	130	355	377	180	252	125	100	17	240	295	18	M10x20 (n.6)	162	185,5	173	178	16	22	251,5	14	51,5	M16
HR121	55 m6	110	25	150	422	426,5	210	300	160	115	22	280	340	18	M12x25 (n.7)	183	224	202	207	19	25	266,5	16	59	M20

		J	J1	M1	M2	NF f8	N1	O1	P	P1	SF	TF
HR041F/U HR051F/U	FA	45°	60°	Ø165	Ø85	130	70	11 (n.4)	160	Ø200	9	3,5
	FB			Ø130	Ø85	110		9 (n.4)	Ø160	/	9	3,5
	FC			Ø115	Ø85	95		9 (n.4)	Ø140	/	9	3
	FD			Ø100	Ø85	80		M8 (n.4)	Ø120	/	9	3
HR061F/U	FA	45°	60°	Ø215	Ø105	180	90	14 (n.4)	200	Ø250	12	4
	FB			Ø165	Ø105	130		11 (n.4)	Ø200	/	12	3,5
HR081F/U HR101F/U	FA	45°	45°	Ø265	Ø130	230	110	14 (n.4)	250	Ø300	15	4
	FB			Ø215	Ø130	180		14 (n.4)	Ø250	/	15	4
	FC			Ø165	Ø130	130		11 (n.4)	Ø200	/	15	3,5
HR121F/U	FA	45°	45°	Ø300	Ø165	250	130	18 (n.4)	300	Ø350	16	5
	FB			Ø265	Ø165	230		14 (n.4)	Ø300	/	16	4
	FC			Ø 215	Ø165	180		14 (n.4)	Ø250	/	16	4

		G2					
IEC	Pm x Dm	HR041F/U/M	HR051F/U/M	HR061F/U/M	HR081F/U/M	HR101F/U/M	HR121F/U/M
071	160x14	69,0	69,0	/	/	/	/
080	200x19	90,0	90,0	90,0	70,0	/	/
090	200x24	90,0	90,0	90,0	70,0	/	/
100-112	250x28	/	105,0	105,0	85,0	75,5	/
132	300x38	/	/	/	110,0	100,5	100,5
160	350x42	/	/	/	/	148,0	148,0
180	350x48	/	/	/	/	148,0	148,0
200	400x55	/	/	/	/	/	185,0

B5	Pm	Dm	bm	tm
071	160	14	5	16,3
080	200	19	6	21,8
090	200	24	8	27,3
100	250	28	8	31,3
112	250	28	8	31,3
132	300	38	10	41,3
160	350	42	12	45,3
180	350	48	14	51,8
200	400	55	16	59,3

3.1.12 CHR..1

CH...

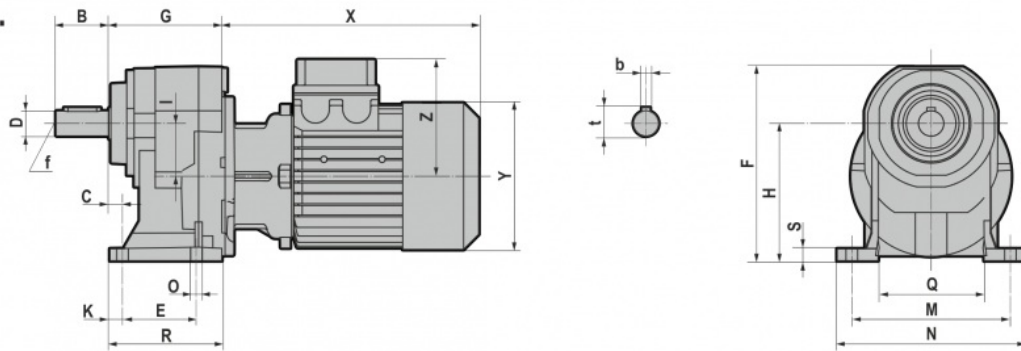

CH...M

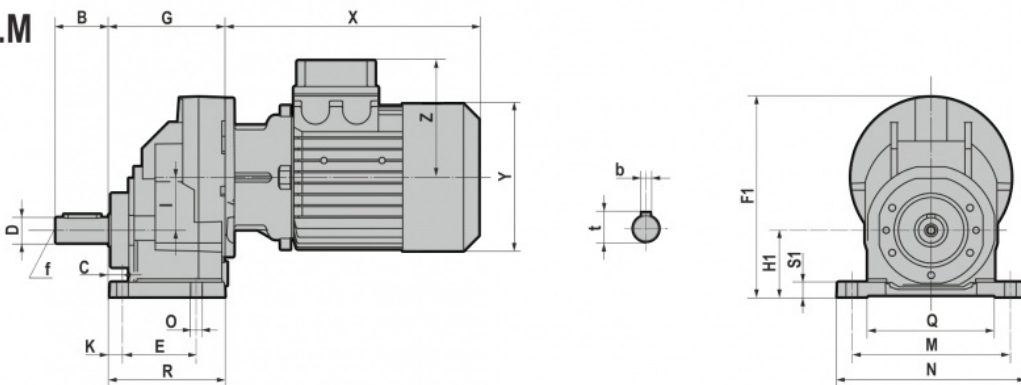

CH...F

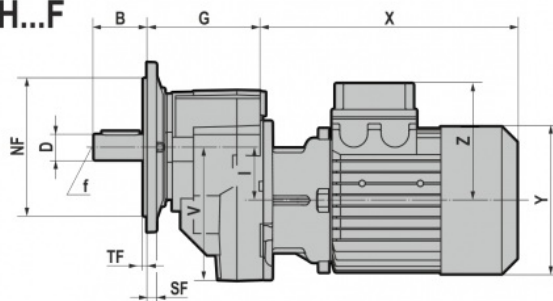

CH...U

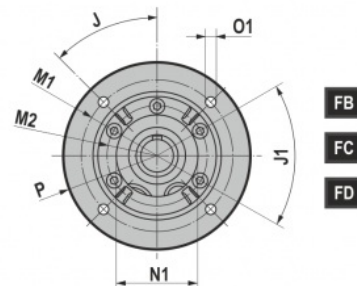
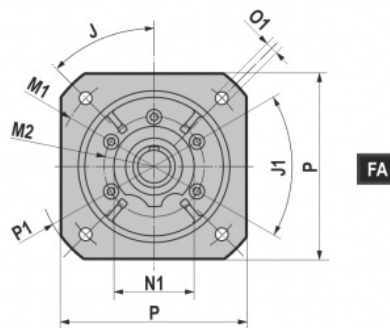
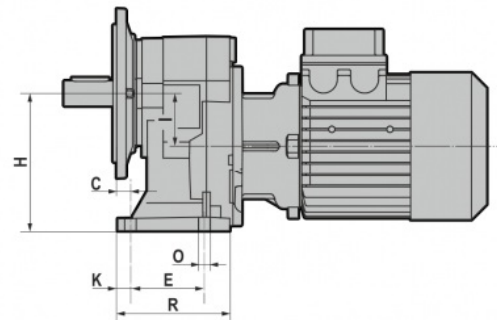

3.1 REDUCERS/GEARED MOTORS

CHR.../F/U/M	D	B	C	E	F	F1	G	H	H1	I	K	M	N	O	O2	Q	Q1	R	R1	S	S1	-V	b	t	f
CHR041	19 j6	40	13	45	168,5	168	100	120	50	42	12	105	130 125 (041M)	9	M8x17 (n.5)	74	55	86,5	98	9,5	8	118	6	21,5	M6
CHR051	24 j6	50	13	70	183,5	189	110	130	63	50	12	150	178	11	M8x17 (n.5)	100	121,5	106	109	11,5	14	126	8	27	M8
CHR061	28 j6	60	16	70	231	216	125	165	80	60	14	165	195	11	M8x17 (n.5)	110	135,5	120	123	15	16	136	8	31	M10
CHR081	38 k6	80	25	85	277	284	135	195	100	80	23	185	230 232 (081M)	14	M10x20 (n.7)	123	151	130	135	15	20	184	10	41	M12
CHR101	48 k6	110	19	130	355	377	180	252	125	100	17	240	295	18	M10x20 (n.6)	162	185,5	173	178	16	22	251,5	14	51,5	M16
CHR121	55 m6	110	25	150	422	426,5	210	300	160	115	22	280	340	18	M12x25 (n.7)	183	224	202	207	19	25	266,5	16	59	M20

		J	J1	M1	M2	NF f8	N1	O1	P	P1	SF	TF
CHR041F/U CHR051F/U	FA	45°	60°	Ø165	Ø85	130	70	11 (n.4)	160	Ø200	9	3,5
	FB			Ø130	Ø85	110		9 (n.4)	Ø160	/	9	3,5
	FC			Ø115	Ø85	95		9 (n.4)	Ø140	/	9	3
	FD			Ø100	Ø85	80		M8 (n.4)	Ø120	/	9	3
CHR061F/U	FA	45°	60°	Ø215	Ø105	180	90	14 (n.4)	200	Ø250	12	4
	FB			Ø165	Ø105	130		11 (n.4)	Ø200	/	12	3,5
CHR081F/U CHR101F/U	FA	45°	45°	Ø265	Ø130	230	110	14 (n.4)	250	Ø300	15	4
	FB			Ø215	Ø130	180		14 (n.4)	Ø250	/	15	4
	FC			Ø165	Ø130	130		11 (n.4)	Ø200	/	15	3,5
CHR121F/U	FA	45°	45°	Ø300	Ø165	250	130	18 (n.4)	300	Ø350	16	5
	FB			Ø265	Ø165	230		14 (n.4)	Ø300	/	16	4
	FC			Ø 215	Ø165	180		14 (n.4)	Ø250	/	16	4

T (IE1 - IE2 - IE3)										
CHR.../F/U/M	063	071	080	090S	090L	100	112	132S	132M/L	
CHR041 CHR051 CHR061	X	215	241	268 *(291)	296 *(329)	321 *(354)	333	351 *(375)	/	/
	Y	121	139	158	173	173	191	211	/	/
	Z	104	112	122	130	130	139	154	/	/
CHR081	X	/	221	248 *(271)	276 *(309)	301 *(334)	335	356 *(380)	405	443
	Y	/	139	158	173	173	191	211	249	249
	Z	/	112	122	130	130	139	154	194	194
CHR101 CHR121	X	/	/	/	267 *(300)	292 *(325)	326	347 *(371)	396	434
	Y	/	/	/	173	173	191	211	249	249
	Z	/	/	/	130	130	139	154	194	194

TB (IE1 - IE2 - IE3)										
CHR.../F/U/M	063	071	080	090S	090L	100	112	132S	132M/L	
CHR041 CHR051 CHR061	X	273	306.5	341 *(364)	373 *(406)	398 *(431)	415	448 *(472)	/	/
	Y	121	139	158	173	173	191	211	/	/
	Z	119	129	137	157	157	168	183	/	/
CHR081	X	/	286.5	321 *(344)	353 *(386)	378 *(411)	417	453 *(477)	505	547
	Y	/	139	158	173	173	191	211	249	249
	Z	/	129	137	157	157	168	183	230	230
CHR101 CHR121	X	/	/	/	343 *(376)	368 *(401)	407	443 *(467)	495	537
	Y	/	/	/	173	173	191	211	249	249
	Z	/	/	/	157	157	168	183	230	230

*TP80B4,TP90S4, TP90L4, TP90S6, TP112M4, TP112M6

3.1.13 IHR..1

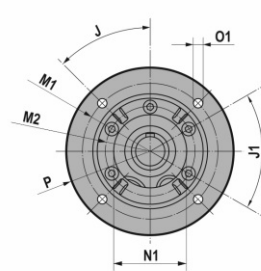
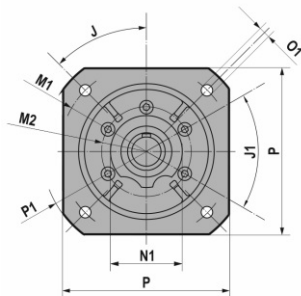
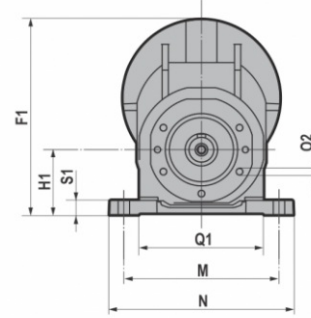
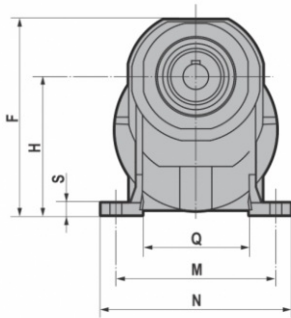
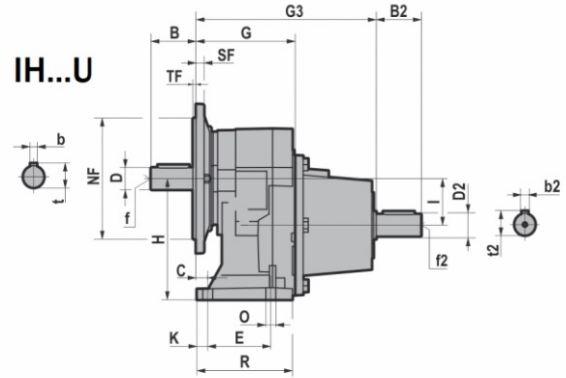
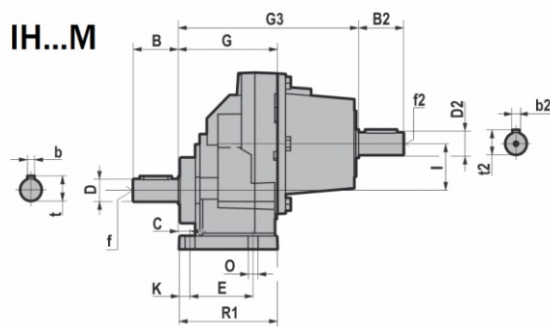
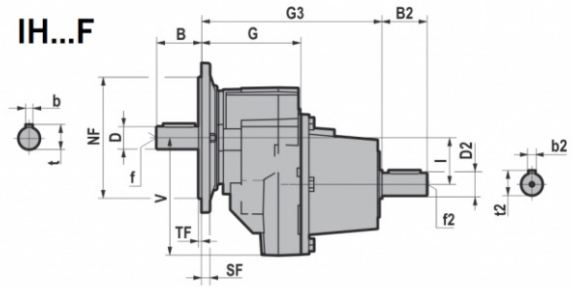
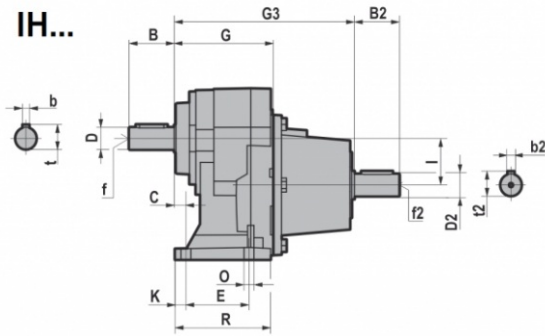

FA

FB

FC

FD

3.1 REDUCERS/GEARED MOTORS

IHR.../F/U/M	D	B	C	E	F	F1	G	H	H1	I	K	M	N	O	O2	Q	Q1	R	R1	S	S1	-V	b	t	f
IHR041	19 j6	40	13	45	168,5	168	100	120	50	42	12	105	130 125 (041M)	9	M8x17 (n.5)	74	55	86,5	98	9,5	8	118	6	21,5	M6
IHR051	24 j6	50	13	70	183,5	189	110	130	63	50	12	150	178	11	M8x17 (n.5)	100	121,5	106	109	11,5	14	126	8	27	M8
IHR061	28 j6	60	16	70	231	216	125	165	80	60	14	165	195	11	M8x17 (n.5)	110	135,5	120	123	15	16	136	8	31	M10
IHR081	38 k6	80	25	85	277	284	135	195	100	80	23	185	230 232 (081M)	14	M10x20 (n.5)	123	151	130	135	15	20	184	10	41	M12
IHR101	48 k6	110	19	130	355	377	180	252	125	100	17	240	295	18	M10x20 (n.6)	162	185,5	173	178	16	22	251,5	14	51,5	M16
IHR121	55 m6	110	25	150	422	426,5	210	300	160	115	22	280	340	18	M12x25 (n.7)	183	224	202	207	19	25	266,5	16	59	M20

		J	J1	M1	M2	NF f8	N1	O1	P	P1	SF	TF
IHR041F/U IHR051F/U	FA	45°	60°	Ø165	Ø85	130	70	11 (n.4)	160	Ø200	9	3,5
	FB			Ø130	Ø85	110		9 (n.4)	Ø160	/	9	3,5
	FC			Ø115	Ø85	95		9 (n.4)	Ø140	/	9	3
	FD			Ø100	Ø85	80		M8 (n.4)	Ø120	/	9	3
IHR061F/U	FA	45°	60°	Ø215	Ø105	180	90	14 (n.4)	200	Ø250	12	4
	FB			Ø165	Ø105	130		11 (n.4)	Ø200	/	12	3,5
IHR081F/U IHR101F/U	FA	45°	45°	Ø265	Ø130	230	110	14 (n.4)	250	Ø300	15	4
	FB			Ø215	Ø130	180		14 (n.4)	Ø250	/	15	4
	FC			Ø165	Ø130	130		11 (n.4)	Ø200	/	15	3,5
IHR121F/U	FA	45°	45°	Ø300	Ø165	250	130	18 (n.4)	300	Ø350	16	5
	FB			Ø265	Ø165	230		14 (n.4)	Ø300	/	16	4
	FC			Ø 215	Ø165	180		14 (n.4)	Ø250	/	16	4

	G3	B2	D2	b2	t2	f2
IHR041	190	40	16 j6	5	18	M6
IHR051	200	50	24 j6	8	27	M8
IHR061	215	50	24 j6	8	27	M8
IHR081	248	60	28 j6	8	31	M10
IHR101	306,5	80	38 k6	10	41	M12
IHR121	336,5	80	38 k6	10	41	M12

3.1.14 H..2/3

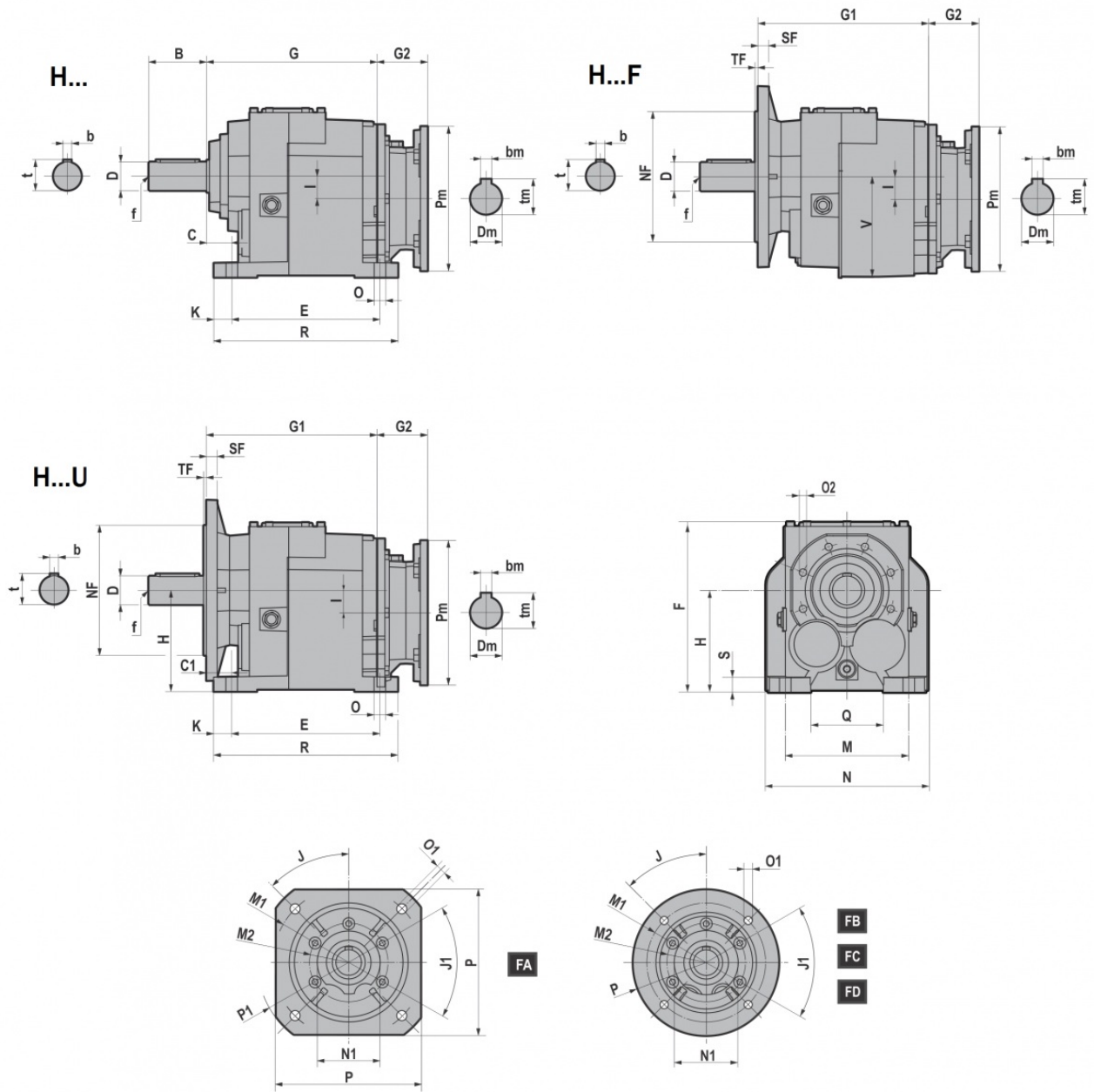

3.1 REDUCERS/GEARED MOTORS

H.../F/U	D	B	b	t	f	C	C1	E	F	G	G1	H	I	K	M	N	O	O2	Q	R	S	-V
H032/H033	25 j6	50	8	28	M10	25	34	130	169	141	150	90	9,2	15	110	140	11	M8x17 (n.5)	60	160	15	92
H042/H043	30 j6	60	8	33	M10	30	30	165	189	152	152	115	18	15	135	170	14	M8x17 (n.5)	85	195	15	115
H052/H053	35 k6	70	10	38	M12	30	30	165	192	187	187	115	25,5	18	135	185	14	M8x17 (n.5)	80	201	18	116
H062/H063	40 k6	80	12	43	M16	35	35	205	234	236	236	140	31	25	170	220	16	M10x20 (n.6)	100	255	20	140
	35 k6	70	10	38	M12																	
H082/H083	50 k6	100	14	53,5	M16	40	40	260	292	272,5	272,5	180	31	27,5	215	280	18	M12x25 (n.7)	140	315	25	180
	40 k6	80	12	43	M16																	
H102/H103	60 m6	120	18	64	M20	40	40	310	364	316	316	225	35,5	27,5	250	330	22	M14x28 (n.7)	159	365	30	227
H122/H123	70 m6	140	20	74,5	M20	45	45	370	408	376,5	376,5	250	47,5	35	290	406	26	M14x30 (n.7)	185,5	440	35	253
H142/H143	90 m6	170	25	95	M20	50	50	410	498	430	430	315	45	40	340	450	26	M16x32 (n.7)	230	490	35	320

...F/U		J	J1	M1	M2	NF f8	N1	O1	P	P1	SF	TF
H032/H033 H042/H043	FA	45°	60°	Ø165	Ø85	130	70	11 (n.4)	160	Ø200	9	3,5
	FB			Ø130	Ø85	110		9 (n.4)	Ø160	/	9	3,5
	FC			Ø115	Ø85	95		9 (n.4)	Ø140	/	9	3
	FD			Ø100	Ø85	80		M8 (n.4)	Ø120	/	9	3
H052/H053	FA	45°	60°	Ø215	Ø105	180	90	14 (n.4)	200	Ø250	12	4
	FB			Ø165	Ø105	130		11 (n.4)	Ø200	/	12	3,5
H062/H063	FA	45°	45°	Ø265	Ø130	230	110	14 (n.4)	250	Ø300	15	4
	FB			Ø215	Ø130	180		14 (n.4)	Ø250	/	15	4
	FC			Ø165	Ø130	130		11 (n.4)	Ø200	/	15	3,5
H082/H083	FA	45°	45°	Ø300	Ø165	250	130	18 (n.4)	300	Ø350	16	5
	FB			Ø265	Ø165	230		14 (n.4)	Ø300	/	16	4
	FC			Ø215	Ø165	180		14 (n.4)	Ø250	/	16	4
H102/H103	FA	45°	45°	Ø350	Ø185	300	150	18 (n.4)	350	Ø400	18	5
	FB			Ø300	Ø185	250		18 (n.4)	Ø350	/	18	5
	FC			Ø265	Ø185	230		14 (n.4)	Ø300	/	18	4
H122/H123	FB	45°	45°	Ø350	Ø200	300	170	18 (n.4)	Ø400	/	18	5
H142/H143	FB	22°30'	45°	Ø400	Ø245	350	210	18 (n.8)	Ø450	/	25	5
	FC	45°		Ø350	Ø245	300		18 (n.4)	Ø400	/	25	5

IEC	Pm x Dm	G2 H.../F/U					
		H032/H033 H042/H043 H052/H053	H062/H063	H082/H083	H102/H103	H122/H123	H142/H143
063	140x11	57,0	/	/	/	/	/
071	160x14	69,0	49,0	/	/	/	/
080	200x19	90,0	70,0	70,0	/	/	/
090	200x24	90,0	70,0	70,0	60,5	/	/
100-112	250x28	105,0	85,0	85,0	75,5	75,5	/
132	300x38	/	110,0	110,0	100,5	100,5	76,0
160	350x42	/	/	157,5	148,0	148,0	123,5
180	350x48	/	/	/	148,0	148,0	123,5
200	400x55	/	/	/	185,0	185,0	160,5
225	450x60	/	/	/	/	/	160,5

B5	Pm	Dm	bm	tm
063	140	11	4	12,8
071	160	14	5	16,3
080	200	19	6	21,8
090	200	24	8	27,3
100	250	28	8	31,3
112	250	28	8	31,3
132	300	38	10	41,3
160	350	42	12	45,3
180	350	48	14	51,8
200	400	55	16	59,3
225	450	60	18	64,4

3.1.15 CH..2/3

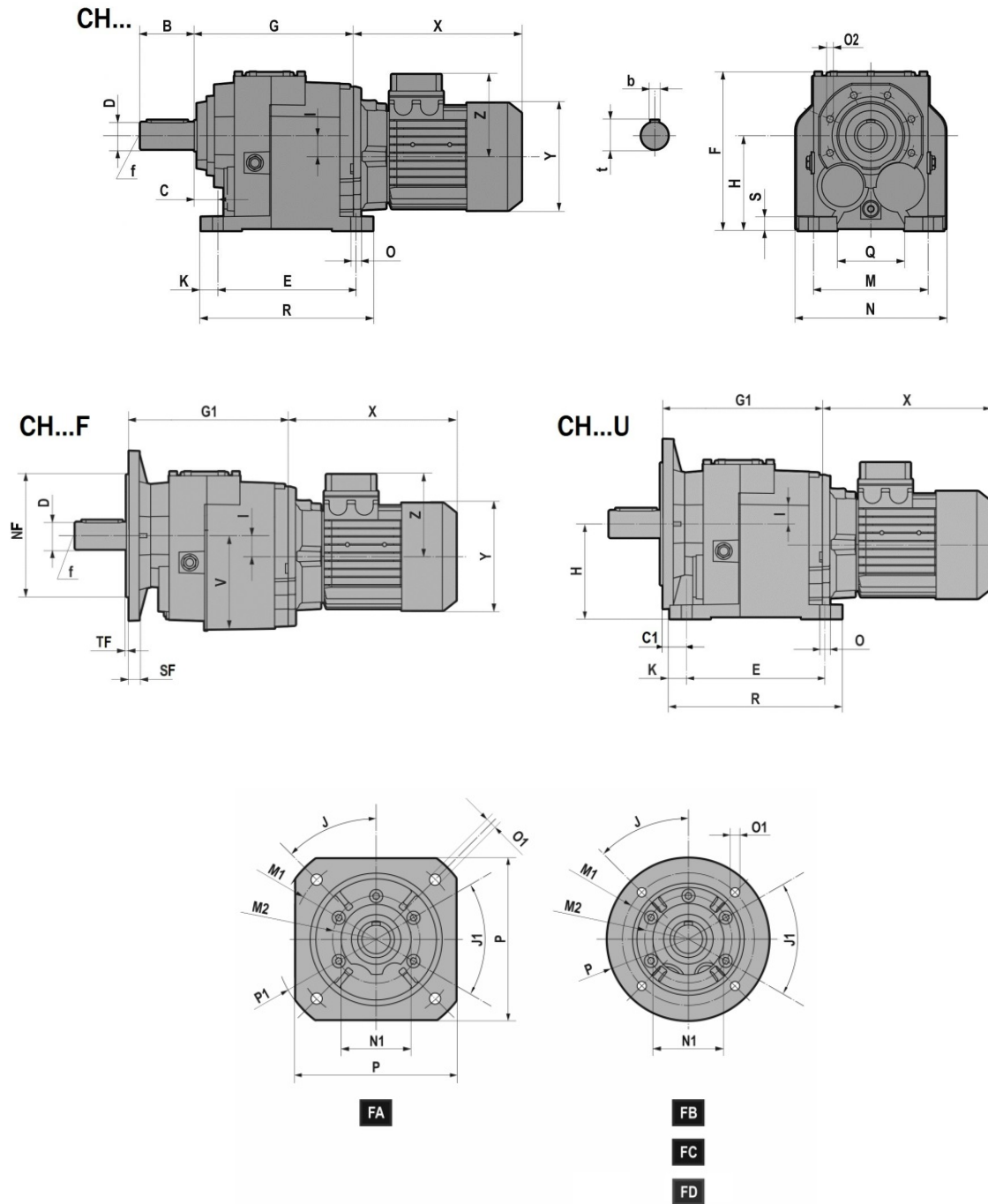

3.1 REDUCERS/GEARED MOTORS

CH.../F/U	D	B	b	t	f	C	C1	E	F	G	G1	H	I	K	M	N	O	O2	Q	R	S	-V
CH032/CH033	25 j6	50	8	28	M10	25	34	130	169	141	150	90	9,2	15	110	140	11	M8x17 (n.5)	60	160	15	92
CH042/CH043	30 j6	60	8	33	M10	30	30	165	189	152	152	115	18	15	135	170	14	M8x17 (n.5)	85	195	15	115
CH052/CH053	35 k6	70	10	38	M12	30	30	165	192	187	187	115	25,5	18	135	185	14	M8x17 (n.5)	80	201	18	116
CH062/CH063	40 k6	80	12	43	M16	35	35	205	234	236	236	140	31	25	170	220	16	M10x20 (n.6)	100	255	20	140
	35 k6	70	10	38	M12																	
CH082/CH083	50 k6	100	14	53,5	M16	40	40	260	292	272,5	272,5	180	31	27,5	215	280	18	M12x25 (n.7)	140	315	25	180
	40 k6	80	12	43	M16																	
CH102/CH103	60 m6	120	18	64	M20	40	40	310	364	316	316	225	35,5	27,5	250	330	22	M14x28 (n.7)	159	365	30	227
CH122/CH123	70 m6	140	20	74,5	M20	45	45	370	408	376,5	376,5	250	47,5	35	290	406	26	M14x30 (n.7)	185,5	440	35	253
CH142/CH143	90 m6	170	25	95	M20	50	50	410	498	430	430	315	45	40	340	450	26	M16x32 (n.7)	230	490	35	320

...F/U		J	J1	M1	M2	NF f8	N1	O1	P	P1	SF	TF
CH032/CH033 CH042/CH043	FA	45°	60°	Ø165	Ø85	130	70	11 (n.4)	160	Ø200	9	3,5
	FB			Ø130	Ø85	110		9 (n.4)	Ø160	/	9	3,5
	FC			Ø115	Ø85	95		9 (n.4)	Ø140	/	9	3
	FD			Ø100	Ø85	80		M8 (n.4)	Ø120	/	9	3
CH052/CH053	FA	45°	60°	Ø215	Ø105	180	90	14 (n.4)	200	Ø250	12	4
	FB			Ø165	Ø105	130		11 (n.4)	Ø200	/	12	3,5
CH062/CH063	FA	45°	45°	Ø265	Ø130	230	110	14 (n.4)	250	Ø300	15	4
	FB			Ø215	Ø130	180		14 (n.4)	Ø250	/	15	4
	FC			Ø165	Ø130	130		11 (n.4)	Ø200	/	15	3,5
CH082/CH083	FA	45°	45°	Ø300	Ø165	250	130	18 (n.4)	300	Ø350	16	5
	FB			Ø265	Ø165	230		14 (n.4)	Ø300	/	16	4
	FC			Ø215	Ø165	180		14 (n.4)	Ø250	/	16	4
CH102/CH103	FA	45°	45°	Ø350	Ø185	300	150	18 (n.4)	350	Ø400	18	5
	FB			Ø300	Ø185	250		18 (n.4)	Ø350	/	18	5
	FC			Ø265	Ø185	230		14 (n.4)	Ø300	/	18	4
CH122/CH123	FB	45°	45°	Ø350	Ø200	300	170	18 (n.4)	Ø400	/	18	5
CH142/CH143	FB	22°30'	45°	Ø400	Ø245	350	210	18 (n.8)	Ø450	/	25	5
	FC	45°		Ø350	Ø245	300		18 (n.4)	Ø400	/	25	5

T (IE1 - IE2 - IE3)										
CH.../F/U	063	071	080	090S	090L	100	112	132S	132M/L	
CH032/CH033 CH042/CH043 CH052/CH053	X	215	241	268 *(291)	296 *(329)	321 *(354)	333	351 *(375)	/	/
	Y	121	139	158	173	173	191	211	/	/
	Z	104	112	122	130	130	139	154	/	/
CH062/CH063 CH082/CH083	X	/	221	248 *(271)	276 *(309)	301 *(334)	335	356 *(380)	405	443
	Y	/	139	158	173	173	191	211	249	249
	Z	/	112	122	130	130	139	154	194	194
CH102/CH103 CH122/CH123	X	/	/	/	267 *(300)	292 *(325)	326	347 *(371)	396	434
	Y	/	/	/	173	173	191	211	249	249
	Z	/	/	/	130	130	139	154	194	194

TB (IE1 - IE2 - IE3)										
CH.../F/U	063	071	080	090S	090L	100	112	132S	132M/L	
CH032/CH033 CH042/CH043 CH052/CH053	X	273	306.5	341 *(364)	373 *(406)	398 *(431)	415	448 *(472)	/	/
	Y	121	139	158	173	173	191	211	/	/
	Z	119	129	137	157	157	168	183	/	/
CH062/CH063 CH082/CH083	X	/	286.5	321 *(344)	353 *(386)	378 *(411)	417	453 *(477)	505	547
	Y	/	139	158	173	173	191	211	249	249
	Z	/	129	137	157	157	168	183	230	230
CH102/CH103 CH122/CH123	X	/	/	/	343 *(376)	368 *(401)	407	443 *(467)	495	537
	Y	/	/	/	173	173	191	211	249	249
	Z	/	/	/	157	157	168	183	230	230

*TP80B4, TP90S4, TP90L4, TP90S6, TP112M4, TP112M

3.1.16 IH..2/3

IH...

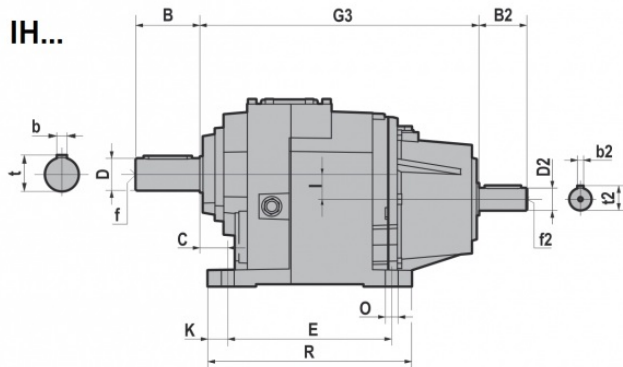

IH...F

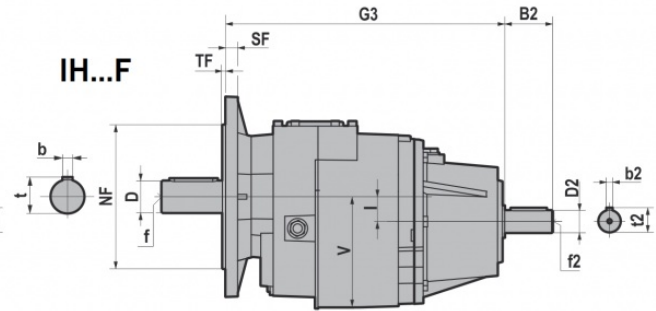

IH...U

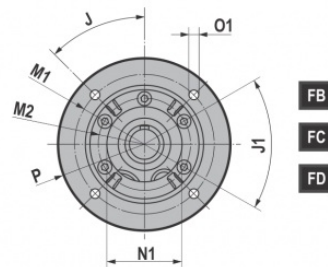
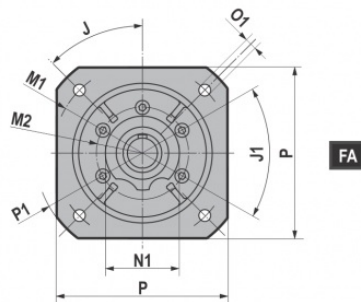
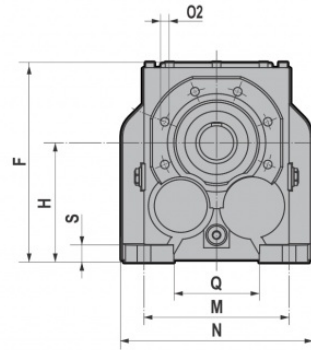
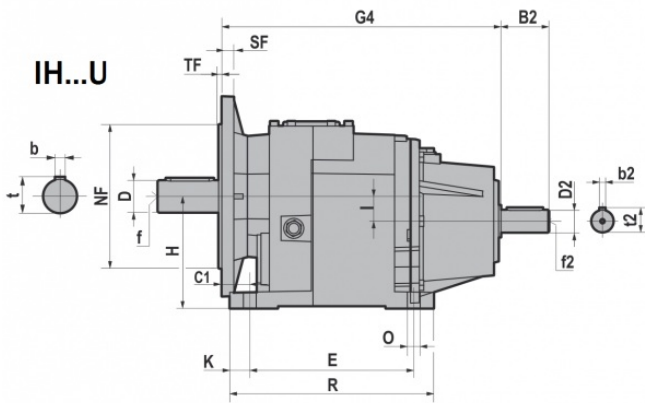

3.1 REDUCERS/GEARED MOTORS

IH.../F/U	D	B	b	t	f	C	C1	E	F	G	G1	H	I	K	M	N	O	O2	Q	R	S	-V
IH032/IH033	25 j6	50	8	28	M10	25	34	130	169	141	150	90	9,2	15	110	140	11	M8x17 (n.5)	60	160	15	92
IH042/IH043	30 j6	60	8	33	M10	30	30	165	189	152	152	115	18	15	135	170	14	M8x17 (n.5)	85	195	15	115
IH052/IH053	35 k6	70	10	38	M12	30	30	165	192	187	187	115	25,5	18	135	185	14	M8x17 (n.5)	80	201	18	116
IH062/IH063	40 k6	80	12	43	M16	35	35	205	234	236	236	140	31	25	170	220	16	M10x20 (n.6)	100	255	20	140
	35 k6	70	10	38	M12																	
IH082/IH083	50 k6	100	14	53,5	M16	40	40	260	292	272,5	272,5	180	31	27,5	215	280	18	M12x25 (n.7)	140	315	25	180
	40 k6	80	12	43	M16																	
IH102/IH103	60 m6	120	18	64	M20	40	40	310	364	316	316	225	35,5	27,5	250	330	22	M14x28 (n.7)	159	365	30	227
IH122/IH123	70 m6	140	20	74,5	M20	45	45	370	408	376,5	376,5	250	47,5	35	290	406	26	M14x30 (n.7)	185,5	440	35	253
IH142/IH143	90 m6	170	25	95	M20	50	50	410	498	430	430	315	45	40	340	450	26	M16x32 (n.7)	230	490	35	320

...F/U		J	J1	M1	M2	NF f8	N1	O1	P	P1	SF	TF
IH032/IH033 IH042/IH043	FA	45°	60°	Ø165	Ø85	130	70	11 (n.4)	160	Ø200	9	3,5
	FB			Ø130	Ø85	110		9 (n.4)	Ø160	/	9	3,5
	FC			Ø115	Ø85	95		9 (n.4)	Ø140	/	9	3
	FD			Ø100	Ø85	80		M8 (n.4)	Ø120	/	9	3
IH052/IH053	FA	45°	60°	Ø215	Ø105	180	90	14 (n.4)	200	Ø250	12	4
	FB			Ø165	Ø105	130		11 (n.4)	Ø200	/	12	3,5
IH062/IH063	FA	45°	45°	Ø265	Ø130	230	110	14 (n.4)	250	Ø300	15	4
	FB			Ø215	Ø130	180		14 (n.4)	Ø250	/	15	4
	FC			Ø165	Ø130	130		11 (n.4)	Ø200	/	15	3,5
IH082/IH083	FA	45°	45°	Ø300	Ø165	250	130	18 (n.4)	300	Ø350	16	5
	FB			Ø265	Ø165	230		14 (n.4)	Ø300	/	16	4
	FC			Ø215	Ø165	180		14 (n.4)	Ø250	/	16	4
IH102/IH103	FA	45°	45°	Ø350	Ø185	300	150	18 (n.4)	350	Ø400	18	5
	FB			Ø300	Ø185	250		18 (n.4)	Ø350	/	18	5
	FC			Ø265	Ø185	230		14 (n.4)	Ø300	/	18	4
IH122/IH123	FB	45°	45°	Ø350	Ø200	300	170	18 (n.4)	Ø400	/	18	5
IH142/IH143	FB	22°30'	45°	Ø400	Ø245	350	210	18 (n.8)	Ø450	/	25	5
	FC	45°		Ø350	Ø245	300		18 (n.4)	Ø400	/	25	5

IH.../F/U	G3	G4	B2	D2	b2	t2	f2
IH032/IH033	231	240	50	24 j6	8	27	M8
IH042/IH043	242	242	50	24 j6	8	27	M8
IH052/IH053	277	277	50	24 j6	8	27	M8
IH062/IH063	349	349	60	28 j6	8	31	M10
IH082/IH083	385,5	385,5	60	28 j6	8	31	M10
IH102/IH103	442,5	442,5	80	38 k6	10	41	M12
IH122/IH123	503	503	80	38 k6	10	41	M12
IH142/IH143	570	570	110	42 k6	12	45	M16

3.2.1 Electric motors

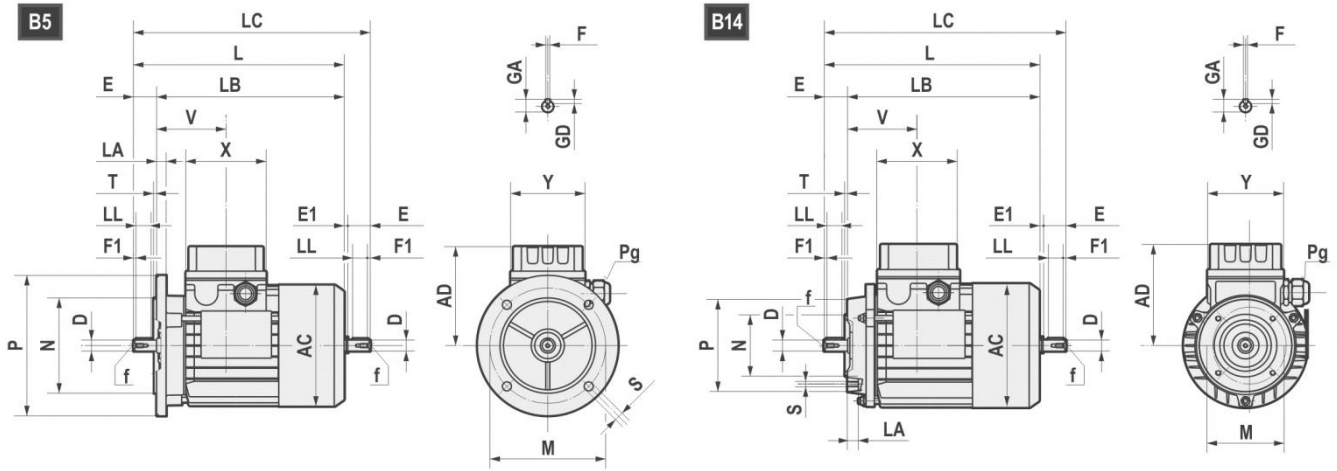

	AC	AD	L	LB	LC	X	Y	V	D	E	E1	f	F1	GA	F	GD
63	121	104	211	188	235,5	80	74	69	11 j6	23	1,5	M4x10	2,5	12,5	4	4
71	139	112	238,5	208,5	271	80	74	74,5	14 j6	30	2,5	M5x12,5	3	16	5	5
80	158	122	272,5 *(296)	232,5 *(256)	314 *(337)	80	74	78	19 j6	40	1,5	M6x16	5	21,5	6	6
90S	173	146	298 *(331)	248 *(281)	349,5 *(381)	98	98	89,5	24 j6	50	1,5	M8x19	5	27	8	7
90L	173	146	323 *(356)	273 *(306)	374,5 *(408)	98	98	89,5	24 j6	50	1,5	M8x19	5	27	8	7
100	191	155	368	308	431,5	98	98	97,5	28 j6	60	3,5	M10x22	7,5	31	8	7
112	211	170	382,5 *(408)	322,5 *(348)	447 *(472)	98	98	100	28 j6	60	3,5	M10x22	7,5	31	8	7
132S	249	195	452	372	536,5	118	118	115,5	38 k6	80	4	M12x28	10	41	10	8
132L	249	195	490	410	574,5	118	118	115,5	38 k6	80	4	M12x28	10	41	10	8
160S	249	195	520	410	/	118	118	115,5	42k6	100	/	M16x36	10	45	12	8

*TP80B4, TP90S4, TP90L4, TP90S6, TP112M4, TP112M6

B5	M	N	P	LA	S	T
63	115	95	140	10	9	3
71	130	110	160	10	9,5	3,5
80	165	130	200	12	11	3,5
90	165	130	200	12	11	3,5
100	215	180	250	15	14	4
112	215	180	250	14,5	14	4
132	265	230	300	20	14	3,5
160	300	250	350	13	18,5	3,5

B14	M	N	P	LA	S	T
63	75	60	90	10	M5	2,5
71	85	70	105	10,5	M6	2,5
80	100	80	120	10,5	M6	3
90	115	95	140	11,5	M8	3
100	130	110	160	15	M8	3,5
112	130	110	160	11,5	M8	3,5
132	165	130	200	20,5	M10	3,5
160	215	180	250	-	M12	4

3.2 ELECTRIC MOTORS

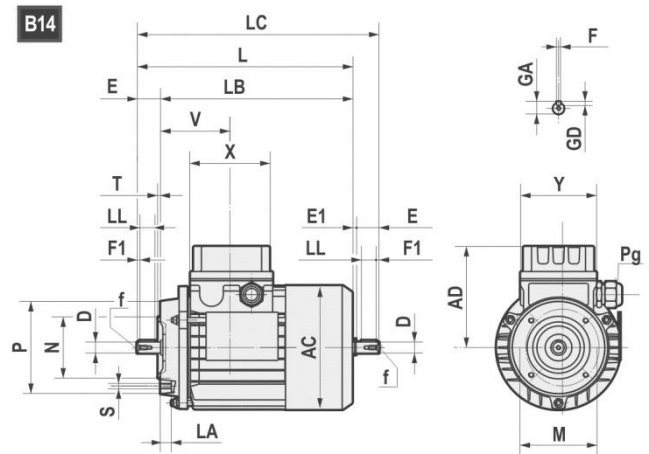
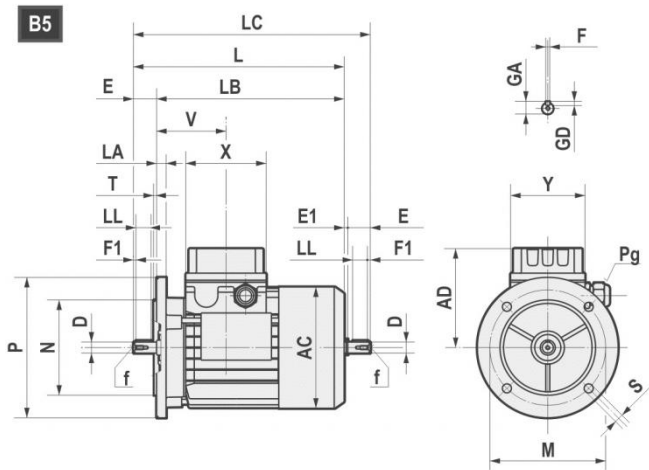

		AC	AD	L	LB	X	D	E	f	GA	F	GD	LL	Pg	
160M	2-4-6	314	251	600	490	158	42	110	M16	45	12	8	90	2-M40x1,5	1-M16x1,5
160L	2-4-6	314	251	645	535	158	42	110	M16	45	12	8	90	2-M40x1,5	1-M16x1,5
180M	2-4	355	267	680	570	158	48	110	M16	51,5	14	9	100	2-M40x1,5	1-M16x1,5
180L	4-6	355	267	720	610	158	48	110	M16	51,5	14	9	100	2-M40x1,5	1-M16x1,5
200L	2-4-6	397	300	785	675	187	55	110	M20	59	16	10	100	2-M50x1,5	1-M16x1,5
225S	4	446	325	820	680	187	60	140	M20	64	18	11	125	2-M50x1,5	1-M16x1,5
225M	2	446	325	815	705	187	55	110	M20	59	16	10	100	2-M50x1,5	1-M16x1,5
225M	4-6	446	325	845	705	187	60	140	M20	64	18	11	125	2-M50x1,5	1-M16x1,5
250M	2-4-6	485	360	910	770	238	60	140	M20	64	18	11	125	2-M63x1,5	1-M16x1,5
250M	2-4-6	485	360	910	770	238	65	140	M20	69	18	11	125	2-M63x1,5	1-M16x1,5
280S	2-4-6	547	390	970	830	238	65	140	M20	69	18	11	125	2-M63x1,5	1-M16x1,5
280S	2-4-6	547	390	970	830	238	75	140	M20	79,5	20	12	125	2-M63x1,5	1-M16x1,5
280M	2-4-6	547	390	1025	885	238	65	140	M20	69	18	11	125	2-M63x1,5	1-M16x1,5
280M	2-4-6	547	390	1025	885	238	75	140	M20	79,5	20	12	125	2-M63x1,5	1-M16x1,5

B5	M	N	P	LA	S	T
160	300	250	350	13	19	5
180	300	250	350	15	19	5
200	350	300	400	17	19	5
225	400	350	450	20	19	5
250	500	450	550	22	19	5
280	500	450	550	22	19	5

3.2.2 Standard high efficiency (TS), high (TH) and premium- (TP) motors

Motovario, three-phase, single polarity motors are available in three different versions (IE1-IE2-IE3) in compliance with standard 60034-30-1 (see table). The efficiency value is calculated according to the method set forth in standard IEC 60034-2-1.

1. IE1: Standard efficiency TS series.
2. IE2: High efficiency TH series
3. IE3: Premium efficiency TP series.

Table of Motovario commercial availability

NOMINAL POWER [kW]	POLES	EFFICIENCY LEVEL		
		IE1	IE2	IE3
$0,09 \leq P_n < 0,75$	4 - 6	TS-TBS	-	-
$0,75 \leq P_n \leq 11$	4	TBS	-	-
$0,75 \leq P_n \leq 5,5$	6	TBS	TH-TBH	TP-TBP
$0,75 \leq P_n \leq 9,2$	4	-	TH-TBH	-
$0,75 \leq P_n \leq 7,5$	4	-	-	TP-TBP
$7,5 \leq P_n \leq 22$	6	TBS (*)	-	TP
$11 \leq P_n \leq 90$	4	-	-	TP
$15 \leq P_n \leq 55$	4	TBS (*)	-	-

(*) Series available on request.

3.2 ELECTRIC MOTORS

3.2.3 Nominal power - [kW]

	63A	63B	63C	71A	71B	71C	80A			80B		
Poles	TS	TS	TS	TS	TS	TS	TS	TH	TP	TS	TH	TP
4	0,12	0,18	0,22	0,25	0,37	0,55	0,55	-	-	-	0,75	0,75
6	0,09	0,12	0,15	0,18	0,25	0,37	0,37	-	-	0,55	-	-

	90S		90L		100LR	100L	100LA		112MR	112MS	112MA	112M
Poles	TH	TP	TH	TP	TP	TP	TH	TP	TP	TP	TH	TP
4	1,1	1,1	1,5	1,5	-	-	2,2	2,2	2,2	3	4	4
6	-	0,75	0,75	-	1,1	1,5	1,1	-	-	-	2,2	2,2

	112MR	112MS	132S	132SA	132MS	132SB	132M	132MA		132MB	
Poles	TP	TP	TP	TH	TP	TH	TP	TH	TP	TH	TP
4	2,2	3	-	5,5	5,5	-	7,5	7,5	-	9,2	-
6	-	-	3	3	-	-	-	4	4	5,5	5,5

	160M	160MA	160MB	160L	160LA	180M	180L
Poles	TP	TP	TP	TP	TP	TP	TP
4	-	11	-	-	15	18,5	22
6	7,5	-	-	11	-	-	15

	200L	200LA	200LB	225S	225M	250M	280S	280M
Poles	TP	TP	TP	TP	TP	TP	TP	TP
4	30	-	-	37	45	55	75	90
6	-	18,5	22	-	-	-	-	-

3.3 WEIGHTS

The values reported in the tables are referred to the weight of the gearbox with lubricant included.

*Weight without motor

* H-PH	063	071	080-090	100-112	132	160-180	200	225	
A31	1,9	2,0	2,2	/	/	/	/	/	- kg
A32	4,2	4,3	4,6	/	/	/	/	/	
A33	4,0	4,1	5,2	/	/	/	/	/	
A41	3,1	3,2	3,5	/	/	/	/	/	
A42	5,2	5,3	5,5	/	/	/	/	/	
A43	5,8	5,9	6,1	/	/	/	/	/	
A51	4,2	4,3	4,5	/	/	/	/	/	
A52	/	/	9,5	13,0	/	/	/	/	
A53	9,9	10,0	10,2	/	/	/	/	/	
A61	/	/	6,6	7,0	/	/	/	/	
A62	/	/	11,3	14,8	/	/	/	/	
A63	12,5	12,6	13,2	/	/	/	/	/	
O32-033	8,4	8,8	9,4	13,7	/	/	/	/	
O42-043	10,9	11,3	11,9	16,2	/	/	/	/	
R041	/	4,8	5,4	/	/	/	/	/	
O52-053	16,0	16,4	17,0	21,3	/	/	/	/	
R051	/	6,7	7,3	11,6	/	/	/	/	
O62-063	/	27,0	29,1	31,2	33,9	/	/	/	
R061	/	/	9,3	13,6	/	/	/	/	
O82-083	/	/	49,1	51,2	53,2	60,5	/	/	
R081	/	/	19,3	21,3	23,9	/	/	/	
102-103	/	/	77,6	79,9	82,7	88,7	/	/	
R101	/	/	/	32,7	35,5	41,5	/	/	
R121	/	/	/	/	36,8	42,8	57,8	/	
122-123	/	/	/	109,5	112,3	118,3	133,3	/	
142-143	/	/	/	/	177,0	184,9	199,1	200,9	

IH	- kg
A32	4,3
A33	5,0
A41	3,3
A42	5,2
A43	5,8
A51	4,2
A52	9,4
A53	9,9
A61	6,5
A62	11,2
A63	12,9
O32-033	11,5
O42-043	14,0
R041	7,5
O52-053	19,1
R051	9,4
O62-063	33,1
R061	11,4
O82-083	53,1
R081	23,2
102-103	87,5
R101	40,3
R121	41,6
122-123	117,1
142-143	192,1

3.3 WEIGHTS

CH	TS									
	063	071	080	090S	090L	100	112	132S	132M	
A32	6,9	8,7	12,7	/	/	/	/	/	/	~ kg
A33	7,6	9,5	13,5	/	/	/	/	/	/	
A41	5,9	7,8	11,8	/	/	/	/	/	/	
A42	7,8	9,7	13,7	15,6	18,1	/	/	/	/	
A43	8,4	10,3	14,3	16,2	18,7	/	/	/	/	
A51	6,2	8,1	12,1	14,0	16,5	/	/	/	/	
A52	/	/	17,2	19,1	21,6	26,2	36,5	/	/	
A53	12,0	13,9	17,9	19,8	22,3	/	/	/	/	
A61	/	/	14,3	16,2	18,7	23,3	33,6	/	/	
A62	/	/	19,2	21,1	23,6	28,2	38,5	/	/	
A63	14,6	16,5	20,5	22,4	24,9	/	/	/	/	
032-033	11,9	12,8	17,5	21,4	23,4	28,9	40,4	/	/	
042-043	14,4	15,3	20,0	23,9	25,9	31,4	42,9	/	/	
R041	/	8,8	13,5	17,4	19,4	/	/	/	/	
052-053	19,5	20,4	25,1	29,0	31,0	36,5	48,0	/	/	
R051	/	10,7	15,4	19,3	21,3	26,8	38,3	/	/	
062-063	/	32,7	37,8	40,2	41,7	46,8	58,2	72,2	83,8	
R061	/	/	17,4	21,3	23,3	28,8	40,3	/	/	
082-083	/	/	59,7	62,1	63,6	68,7	80,1	94,1	105,7	
R081	/	/	27,1	29,5	31	36,1	47,5	61,5	73,1	
102-103	/	/	/	93,8	94,8	100,8	110,8	125,8	134,8	
R101	/	/	/	/	/	49,6	59,6	74,6	83,6	
R121	/	/	/	/	/	/	/	77	86	
122-123	/	/	/	/	/	134,5	144,5	159,5	168,5	

CH	TH							
	080	090S	090L	100	112	132S	132M	
A32	14,4	/	/	/	/	/	/	~ kg
A33	15,2	/	/	/	/	/	/	
A41	13,5	/	/	/	/	/	/	
A42	15,4	17,9	20	/	/	/	/	
A43	16,0	18,5	20,6	/	/	/	/	
A51	13,8	16,3	18,4	/	/	/	/	
A52	18,9	21,5	23,6	28,5	39,6	/	/	
A53	19,6	22,1	24,3	/	/	/	/	
A61	16,0	18,6	20,7	25,6	36,7	/	/	
A62	20,9	23,4	25,6	30,5	41,6	/	/	
A63	22,1	24,7	26,8	/	/	/	/	
032-033	19,2	23,7	25,3	31,2	43,5	/	/	
042-043	21,7	26,3	27,9	33,8	46	/	/	
R041	15,2	19,7	21,3	/	/	/	/	
052-053	26,8	31,4	33	38,9	51,1	/	/	
R051	17,1	21,6	23,2	29,1	41,4	/	/	
062-063	39,5	42,5	43,7	49,1	61,3	77,5	90,6	
R061	19,1	23,6	25,2	31,1	43,4	/	/	
082-083	61,4	64,4	65,6	71	83,2	99,4	112,5	
R081	28,8	31,8	33	38,4	50,6	66,8	79,9	
102-103	/	96,1	96,8	103,1	113,9	131,1	141,6	
R101	/	/	/	51,9	62,7	79,9	90,4	
R121	/	/	/	/	/	82,3	92,8	
122-123	/	/	/	136,8	147,6	164,8	175,3	

CH	TBS									
	063	071	080	090S	090L	100	112	132S	132M	
A32	8,2	10,6	15,8	/	/	/	/	/	/	~ kg
A33	8,9	11,4	16,6	/	/	/	/	/	/	
A41	7,2	9,7	14,9	/	/	/	/	/	/	
A42	9,1	11,6	16,8	20,5	23,0	/	/	/	/	
A43	9,7	12,2	17,4	21,1	23,6	/	/	/	/	
A51	7,5	10	15,2	18,9	21,4	/	/	/	/	
A52	/	/	20,3	24,3	26,5	31,1	44,8	/	/	
A53	13,3	15,8	21	24,7	27,2	/	/	/	/	
A61	/	/	17,4	21,1	23,6	28,2	41,9	/	/	
A62	/	/	22,3	26	28,5	33,1	46,8	/	/	
A63	15,9	18,4	23,6	27,3	29,8	/	/	/	/	
032-033	13,4	15	21	26,9	28,9	34,4	50,1	/	/	
042-043	15,9	17,5	23,5	29,4	31,4	36,9	52,6	/	/	
R041	/	11	17	22,9	24,9	/	/	/	/	
052-053	21,0	22,6	28,6	34,5	36,5	42	57,7	/	/	
R051	/	12,9	18,9	24,8	26,8	32,3	48	/	/	
062-063	/	34,9	41,3	45,7	47,2	52,3	67,9	82,5	98,5	
R061	/	/	20,9	26,8	28,8	34,3	50	/	/	
082-083	/	/	63,2	67,6	69,1	74,2	89,8	104,4	120,4	
R081	/	/	30,6	35	36,5	41,6	57,2	71,8	87,8	
102-103	/	/	/	99,4	100,4	106,4	120,6	136,2	149,6	
R101	/	/	/	/	/	55	69,3	85	98,3	
R121	/	/	/	/	/	/	/	87,3	100,7	
122-123	/	/	/	/	/	140	154,2	169,8	183,2	

CH	TBH							
	080	090S	090L	100	112	132S	132M	
A32	17,5	/	/	/	/	/	/	~ kg
A33	18,3	/	/	/	/	/	/	
A41	16,6	/	/	/	/	/	/	
A42	18,5	22,8	25,0	/	/	/	/	
A43	19,1	23,4	25,6	/	/	/	/	
A51	16,9	21,2	23,4	/	/	/	/	
A52	22	26,6	28,5	34,8	47,9	/	/	
A53	22,7	27	29,2	/	/	/	/	
A61	19,1	23,4	25,6	31,9	45	/	/	
A62	24	28,3	30,5	36,8	49,9	/	/	
A63	25,3	29,6	31,8	/	/	/	/	
032-033	22,7	29,2	30,9	38,1	53,2	/	/	
042-043	25,2	31,7	33,4	40,6	55,7	/	/	
R041	18,6	25,2	26,9	/	/	/	/	
052-053	30,3	36,9	38,6	45,8	60,9	/	/	
R051	20,6	27,1	28,8	36	51,1	/	/	
062-063	43	48	49,2	56	71	87,8	105	
R061	22,6	29,1	30,8	38	53,1	/	/	
082-083	64,9	69,9	71,1	77,9	92,9	109,7	126,9	
R081	32,3	37,3	38,5	45,3	60,3	77,1	94,3	
102-103	/	101,7	102,4	110,1	123,7	141,5	156,1	
R101	/	/	/	58,7	72,4	90,3	104,8	
R121	/	/	/	/	/	92,6	107,2	
122-123	/	/	/	143,7	157,3	175,1	189,7	

3.4 SHAFT END

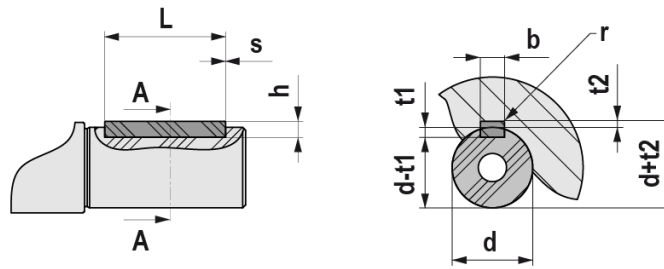

UNI 6604 - DIN 6885														
d		b x h			Tol. b/h	L		$\frac{s}{\min / \max}$	b	t1	t2	Tol. t1/t2	r max	
	6	8	2	x	2	h9 / h9	6	20	0,16 0,25	2	1,2	1	0,1 0	0,08 0,16
>	8	10	3	x	3		6	36		3	1,8	1,4		
>	10	12	4	x	4		8	45		4	2,5	1,8		
>	12	17	5	x	5		10	56	0,25 0,4	5	3	2,3		0,16 0,25
>	17	22	6	x	6		14	70		6	3	2,8		
>	22	30	8	x	7		18	90		8	4	3,3		
>	30	38	10	x	8	22	110	0,4 0,6	10	5	3,3	0,2 0	0,25 0,4	
>	38	44	12	x	8	28	140		12	5	3,3			
>	44	50	14	x	9	36	160		14	5,5	3,8			
>	50	58	16	x	10	45	180		16	6	4,3		0,4 0,6	
>	58	65	18	x	11	50	200		18	7	4,4			
>	65	75	20	x	12	56	110		20	7,5	4,9			
>	75	85	22	x	14	63	140	0,6 0,8	22	9	5,4	0,4 0,6		
>	85	95	25	x	14	70	160		25	9	5,4			
>	95	110	28	x	16	80	180		28	10	6,4			
>	110	130	32	x	18	90	200		32	11	7,4			
>	130	150	36	x	20	100	160		36	12	8,4		0,3 0	
>	150	170	40	x	22	110	180		40	13	9,4			
>	170	200	45	x	25	125	200	45	14	10,4				

4.1 OUTPUT FLANGE

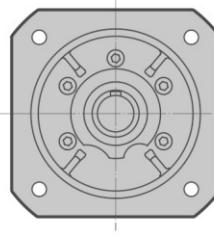
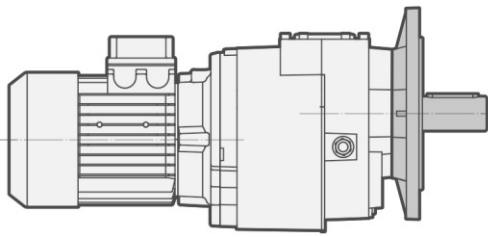

FA

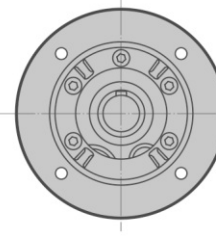

FB FC FD

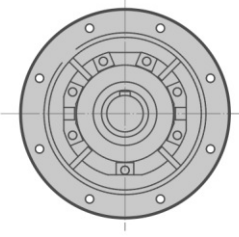

FB (H140)

H...F/H...U		
R041 R051	032/033 042/043	FA
		FB
		FC
		FD
R061	052/053	FA
		FB
R081 R101	062/063	FA
		FB
		FC
R121	082/083	FA
		FB
		FC
-	102/103	FA
		FB
		FC
	122/123	FA
		FB
		FC
142/143	142/143	FA
		FB
		FC

4.2 BACKSTOP DEVICE

The gear reducer can be supplied with backstop device on input shaft. Backstop device allows output shaft rotation in only one sense of direction; according to the size, it is available in the input flange or in the motor with the same dimensions. It is important to specify the required sense of direction on the order. It is device is not available for mounting position V1/V5 with motor size IEC 100...225.



Certified accessory for ATEX 3G/3D, only.

SENSE OF DIRECTION AVAILABLE

H... 1 - H... 1F - H... 1U - H... M - H... 3 - H... 3F - H... 3U

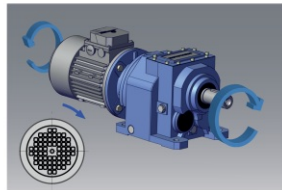

CLOCKWISE SENSE OF DIRECTION
REFERRED TO HIGH SPEED SHAFT

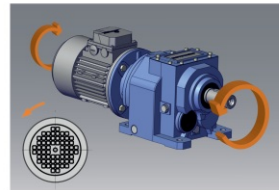

COUNTER CLOCKWISE SENSE OF DIRECTION
REFERRED TO HIGH SPEED SHAFT

H... 2 - H... 2F - H... 2U

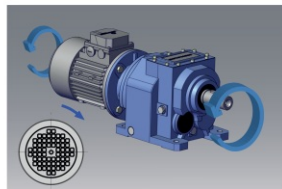

CLOCKWISE SENSE OF DIRECTION
REFERRED TO HIGH SPEED SHAFT

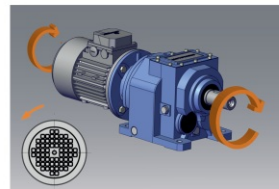

COUNTER CLOCKWISE SENSE OF DIRECTION
REFERRED TO HIGH SPEED SHAFT

4.2 BACKSTOP DEVICE

	063	071	080	090	100-112	132	160	180	200	225
	140x11	160x14	200x19	200x24	250x28	300x38	350x42	350x48	400x55	450x60
H032		B5	B5	B5	B5					
H033	B5	B5	B5	B5						
HR041		B5	B5	B5						
H042		B5	B5	B5	B5					
H043	B5	B5	B5	B5						
HR051		B5	B5	B5	B5					
H052		B5	B5	B5	B5					
H053	B5	B5	B5	B5						
HR061			B5	B5	B5					
H062			B5	B5	B5	B5				
H063		B5	B5	B5	B5					
HR081			B5	B5	B5	B5				
H082			B5	B5	B5	B5	B5			
H083			B5	B5	B5	B5				
HR101					B5	B5	B5	B5		
H102					B5	B5	B5	B5		
H103				B5	B5	B5	B5			
HR121						B5	B5	B5	B5	
H122						B5	B5	B5	B5	
H123					B5	B5	B5	B5	B5	
H142							B5	B5	B5	B5
H143						B5	B5	B5	B5	

4.3 REINFORCED OIL SEALS FOR OUTPUT SHAFT

The reinforced seal can be done depending on the gearbox size by means of two oil seals or through the standard oil seal with VRM ring. The difference of the two solutions is explained on the drawings.

The helical gear reducers from size 060 to size 140 (except for single stage) in V1/ V5 mounting position, are already equipped with 2 oil seals as standard.

On request the gear reducer can be supplied with fluoroelastomer FPM (FKM) seals.

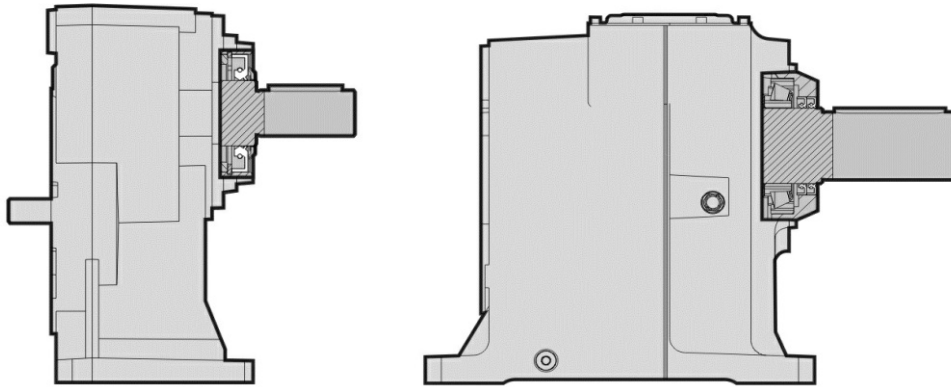

	Double oil seal	VRM ring
HR041		X
HR051		X
HR061		X
HR081		X
HR101		X
HR121		X
H032/3		X
H042/3		X
H052/3		X
H062/3	X	
H082/3	X	
H102/3	X	
H122/3	X	
H142/3	X	

5.1 ATEX AVAILABILITY

HA	ATEX 3G - 3D	ATEX 2G - 2D
HA31	✓	✓
HA41-HA51-HA61	✓	NO
HA32/3-HA42/3-HA52/3-HA62/3	✓	NO
CHA	ATEX 3G - 3D	ATEX 2G - 2D
CHA41-CHA51-CHA61	✓	NO
CHA32/3-CHA42/3-CHA52/3-CHA62/3	✓	NO
H	ATEX 3G - 3D	ATEX 2G - 2D
HR041-HR051-HR061	✓	✓
HR081-HR101-HR121	✓	✓
H032/3-H042/3-H052/3	✓	✓
H062/3-H082/3-H102/3-H122/3-H142/3	✓	✓
CH	ATEX 3G - 3D	ATEX 2G - 2D
CHR041-CHR051-CHR061	✓	NO
CHR081-CHR101-CHR121	✓	NO
CH032/3-CH042/3-CH052/3	✓	NO
CH062/3-CH082/3-CH102/3-CH122/3	✓	NO

6.1 H/HA GEARED MOTORS (50Hz)

0,09 kW

n2 [rpm]	M2 [Nm]	fs	i	Gear reducer	Size	Motor Pole	Fr2 [N]
136,5	6	3,2	6,30	HA31	63A	6	972
109,2	8	2,5	7,88	HA31	63A	6	1047
109,2	8	2,7	7,88	HA41	63A	6	1058
79,4	11	1,1	10,83	HA31	63A	6	1100
79,4	11	1,6	10,83	HA41	63A	6	1100
79,4	11	2,0	10,83	HA51	63A	6	3000
35,0	24	2,6	24,55	HA32	63A	6	2000
28,2	30	2,3	30,55	HA32	63A	6	2000
24,3	34	2,2	35,44	HA32	63A	6	2000
19,5	43	1,8	44,10	HA32	63A	6	2000
19,5	43	2,8	44,10	HA42	63A	6	4300
17,6	47	1,4	48,75	HA32	63A	6	2000
17,6	47	2,3	48,75	HA42	63A	6	4300
16,8	49	1,7	51,32	HA33	63A	6	2000
16,8	49	2,6	51,32	HA43	63A	6	4300
14,4	57	1,5	59,65	HA33	63A	6	2000
14,4	57	2,2	59,65	HA43	63A	6	4300
14,2	59	1,4	60,67	HA32	63A	6	2000
14,2	59	2,0	60,67	HA42	63A	6	4300
12,9	63	2,7	66,78	H033	63A	6	5500
11,9	69	1,3	72,27	HA33	63A	6	2000
11,9	69	1,9	72,27	HA43	63A	6	4300
11,5	71	2,4	74,84	H033	63A	6	5500
9,9	83	3,1	87,05	H043	63A	6	6600
9,8	84	3,0	88,02	HA53	63A	6	6000
9,6	85	1,5	89,94	HA43	63A	6	4300
8,7	94	1,8	99,27	H033	63A	6	5500
8,0	103	1,7	108,05	H033	63A	6	5500
7,8	105	1,2	110,51	HA43	63A	6	4300
7,7	106	2,4	111,61	HA53	63A	6	6000
7,5	109	2,4	114,55	H043	63A	6	6600
7,0	117	1,4	123,71	H033	63A	6	5500
6,8	119	2,1	125,69	H043	63A	6	6600
6,2	132	2,0	138,71	HA53	63A	6	6000
6,2	132	3,1	138,71	HA63	63A	6	8000
6,1	135	1,9	142,04	H043	63A	6	6600
6,0	136	1,3	143,33	H033	63A	6	5500
5,5	149	2,9	157,29	H053	63A	6	8000
5,3	155	1,7	163,05	HA53	63A	6	6000
5,3	155	2,7	163,05	HA63	63A	6	8000
5,2	157	1,6	165,38	H043	63A	6	6600
4,4	185	2,3	194,56	H053	63A	6	8000

6.1 H/HA GEARED MOTORS (50Hz)

0,09 kW

n2 [rpm]	M2 [Nm]	fs	i	Gear reducer	Size	Motor Pole	Fr2 [N]
4,3	190	1,3	200,27	HA53	63A	6	6000
4,3	190	2,1	200,27	HA63	63A	6	8000
4,2	195	1,3	205,07	H043	63A	6	6600
4,0	205	2,1	216,38	H053	63A	6	8000
3,8	216	1,2	227,50	H043	63A	6	6600
3,7	223	1,1	235,41	HA53	63A	6	6000
3,7	223	1,8	235,41	HA63	63A	6	8000
3,2	254	1,7	267,65	H053	63A	6	8000
3,0	270	1,5	284,81	HA63	63A	6	8000
2,4	336	1,2	353,98	HA63	63A	6	8000

0,12 kW

n2 [rpm]	M2 [Nm]	fs	i	Gear reducer	Size	Motor Pole	Fr2 [N]
181,1	6	3,1	4,75	HA31	63B	6	884
170,2	7	2,9	7,88	HA31	63A	4	903
170,2	7	3,2	7,88	HA41	63A	4	913
168,6	7	3,0	5,10	HA31	63B	6	906
157,7	7	2,8	5,45	HA31	63B	6	926
136,5	8	2,4	6,30	HA31	63B	6	972
123,7	9	1,3	10,83	HA31	63A	4	1004
123,7	9	1,9	10,83	HA41	63A	4	1015
123,7	9	2,3	10,83	HA51	63A	4	2798
109,2	10	1,8	7,88	HA31	63B	6	1047
109,2	10	2,0	7,88	HA41	63B	6	1058
79,4	14	1,2	10,83	HA41	63B	6	1100
79,4	14	1,5	10,83	HA51	63B	6	3000
52,2	21	2,7	16,49	HA32	63B	6	1873
43,9	25	2,7	30,55	HA32	63A	4	1985
42,4	26	2,5	20,26	HA32	63B	6	2000
37,8	29	2,6	35,44	HA32	63A	4	2000
35,0	32	1,9	24,55	HA32	63B	6	2000
30,4	36	2,1	44,10	HA32	63A	4	2000
30,4	36	3,3	44,10	HA42	63A	4	4300
28,2	39	1,7	30,55	HA32	63B	6	2000
28,2	39	3,0	30,55	HA42	63B	6	4300
27,5	40	1,7	48,75	HA32	63A	4	2000
27,5	40	2,8	48,75	HA42	63A	4	4300
26,1	41	2,0	51,32	HA33	63A	4	2000
26,1	41	3,1	51,32	HA43	63A	4	4300
24,3	46	1,7	35,44	HA32	63B	6	2000
24,3	46	2,8	35,44	HA42	63B	6	4300

6.1 H/HA GEARED MOTORS (50Hz)

0,12 kW

n2 [rpm]	M2 [Nm]	fs	i	Gear reducer	Size	Motor Pole	Fr2 [N]
22,5	48	1,8	59,65	HA33	63A	4	2000
22,5	48	2,6	59,65	HA43	63A	4	4300
22,1	50	1,6	60,67	HA32	63A	4	2000
22,1	50	2,4	60,67	HA42	63A	4	4300
20,1	54	3,2	66,78	H033	63A	4	5500
19,5	57	1,4	44,10	HA32	63B	6	2000
19,5	57	2,1	44,10	HA42	63B	6	4300
18,5	58	1,5	72,27	HA33	63A	4	2000
18,5	58	2,2	72,27	HA43	63A	4	4300
17,9	60	2,9	74,84	H033	63A	4	5500
17,6	63	1,1	48,75	HA32	63B	6	2000
17,6	63	1,8	48,75	HA42	63B	6	4300
16,8	65	1,3	51,32	HA33	63B	6	2000
16,8	65	2,0	51,32	HA43	63B	6	4300
16,0	68	2,5	53,59	H033	63B	6	5500
14,9	72	1,2	89,94	HA33	63A	4	2000
14,9	72	1,8	89,94	HA43	63A	4	4300
14,4	75	1,1	59,65	HA33	63B	6	2000
14,4	75	1,7	59,65	HA43	63B	6	4300
14,2	78	1,0	60,67	HA32	63B	6	2000
14,2	78	1,5	60,67	HA42	63B	6	4300
13,5	80	2,1	99,27	H033	63A	4	5500
12,9	84	2,0	66,78	H033	63B	6	5500
12,4	87	2,0	108,05	H033	63A	4	5500
12,1	89	1,4	110,51	HA43	63A	4	4300
12,0	90	2,9	111,61	HA53	63A	4	6000
11,9	91	1,4	72,27	HA43	63B	6	4300
11,7	92	2,8	114,55	H043	63A	4	6600
11,5	95	1,8	74,84	H033	63B	6	5500
11,5	95	2,7	74,88	HA53	63B	6	6000
11,2	97	2,6	76,67	H043	63B	6	6600
10,8	99	1,7	123,71	H033	63A	4	5500
10,7	101	2,5	125,69	H043	63A	4	6600
10,0	108	1,2	133,88	HA43	63A	4	4300
9,9	110	2,3	87,05	H043	63B	6	6600
9,8	111	2,3	88,02	HA53	63B	6	6000
9,7	112	2,3	138,71	HA53	63A	4	6000
9,6	114	1,1	89,94	HA43	63B	6	4300
9,4	114	2,2	142,04	H043	63A	4	6600
9,3	115	1,5	143,33	H033	63A	4	5500
8,7	126	1,3	99,27	H033	63B	6	5500
8,5	126	3,4	157,29	H053	63A	4	8000

6.1 H/HA GEARED MOTORS (50Hz)

0,12 kW

n2 [rpm]	M2 [Nm]	fs	i	Gear reducer	Size	Motor Pole	Fr2 [N]
8,2	131	2,0	163,05	HA53	63A	4	6000
8,2	131	3,1	163,05	HA63	63A	4	8000
8,1	133	1,9	165,38	H043	63A	4	6600
8,0	137	1,3	108,05	H033	63B	6	5500
7,9	138	3,1	108,95	H053	63B	6	8000
7,7	141	1,8	111,61	HA53	63B	6	6000
7,7	141	2,9	111,61	HA63	63B	6	8000
7,5	144	1,2	178,61	H033	63A	4	5500
7,5	145	1,8	114,55	H043	63B	6	6600
7,0	157	1,1	123,71	H033	63B	6	5500
6,9	156	2,7	194,56	H053	63A	4	8000
6,8	159	1,1	197,17	H033	63A	4	5500
6,8	159	1,6	125,69	H043	63B	6	6600
6,7	161	1,6	200,27	HA53	63A	4	6000
6,7	161	2,5	200,27	HA63	63A	4	8000
6,5	165	1,6	205,07	H043	63A	4	6600
6,4	170	2,5	134,76	H053	63B	6	8000
6,2	174	2,4	216,38	H053	63A	4	8000
6,2	175	1,5	138,71	HA53	63B	6	6000
6,2	175	2,3	138,71	HA63	63B	6	8000
6,1	180	1,4	142,04	H043	63B	6	6600
5,9	183	1,4	227,50	H043	63A	4	6600
5,7	189	1,4	235,41	HA53	63A	4	6000
5,7	189	2,2	235,41	HA63	63A	4	8000
5,5	199	2,2	157,29	H053	63B	6	8000
5,3	206	1,3	163,05	HA53	63B	6	6000
5,3	206	2,0	163,05	HA63	63B	6	8000
5,2	209	1,2	165,38	H043	63B	6	6600
5,0	215	2,0	267,65	H053	63A	4	8000
4,8	227	1,1	282,10	H043	63A	4	6600
4,7	229	1,1	284,81	HA53	63A	4	6000
4,7	229	1,8	284,81	HA63	63A	4	8000
4,4	246	1,7	194,56	H053	63B	6	8000
4,3	253	1,6	200,27	HA63	63B	6	8000
4,0	274	1,6	216,38	H053	63B	6	8000
3,8	285	1,4	353,98	HA63	63A	4	8000
3,7	298	1,4	235,41	HA63	63B	6	8000
3,2	339	1,3	267,65	H053	63B	6	8000
3,0	360	1,1	284,81	HA63	63B	6	8000

6.1 H/HA GEARED MOTORS (50Hz)

0,15 kW

n2 [rpm]	M2 [Nm]	fs	i	Gear reducer	Size	Motor Pole	Fr2 [N]
255,0	6	3,1	3,18	HA31	63C	6	789
241,3	6	2,9	3,36	HA31	63C	6	804
209,5	7	2,7	3,87	HA31	63C	6	842
192,2	7	2,5	4,21	HA31	63C	6	867
170,5	8	2,3	4,75	HA31	63C	6	902
170,5	8	3,2	4,75	HA41	63C	6	912
158,8	9	2,3	5,10	HA31	63C	6	924
148,5	9	2,1	5,45	HA31	63C	6	945
148,5	9	2,8	5,45	HA41	63C	6	955
128,6	11	1,8	6,30	HA31	63C	6	991
102,9	14	1,4	7,88	HA31	63C	6	1068
102,9	14	1,5	7,88	HA41	63C	6	1080
102,9	14	2,5	7,88	HA51	63C	6	2975
74,8	19	1,1	10,83	HA51	63C	6	3000
61,1	23	2,6	13,25	HA32	63C	6	1777
49,1	28	2,1	16,49	HA32	63C	6	1911
40,0	35	1,9	20,26	HA32	63C	6	2000
33,0	42	1,4	24,55	HA32	63C	6	2000
33,0	42	2,7	24,55	HA42	63C	6	4300
26,5	52	1,3	30,55	HA32	63C	6	2000
26,5	52	2,3	30,55	HA42	63C	6	4300
22,9	61	1,3	35,44	HA32	63C	6	2000
22,9	61	2,1	35,44	HA42	63C	6	4300
18,4	76	1,0	44,10	HA32	63C	6	2000
18,4	76	1,6	44,10	HA42	63C	6	4300
16,6	84	1,3	48,75	HA42	63C	6	4300
16,3	84	3,1	49,80	HA53	63C	6	6000
15,8	86	1,5	51,32	HA43	63C	6	4300
15,1	90	1,9	53,59	H033	63C	6	5500
13,6	100	1,3	59,65	HA43	63C	6	4300
13,4	104	1,2	60,67	HA42	63C	6	4300
13,4	101	2,5	60,25	HA53	63C	6	6000
13,1	104	2,5	61,83	H043	63C	6	6600
12,1	112	1,5	66,78	H033	63C	6	5500
11,2	121	1,0	72,27	HA43	63C	6	4300
10,8	126	1,4	74,84	H033	63C	6	5500
10,8	126	2,0	74,88	HA53	63C	6	6000
10,6	129	2,0	76,67	H043	63C	6	6600
9,3	146	1,8	87,05	H043	63C	6	6600
9,2	148	1,7	88,02	HA53	63C	6	6000
9,2	148	2,8	88,02	HA63	63C	6	8000
8,9	152	2,8	90,51	H053	63C	6	8000

6.1 H/HA GEARED MOTORS (50Hz)

0,15 kW

n2 [rpm]	M2 [Nm]	fs	i	Gear reducer	Size	Motor Pole	Fr2 [N]
8,2	167	1,0	99,27	H033	63C	6	5500
7,4	183	2,3	108,95	H053	63C	6	8000
7,3	187	1,4	111,61	HA53	63C	6	6000
7,3	187	2,2	111,61	HA63	63C	6	8000
7,1	192	1,3	114,55	H043	63C	6	6600
6,4	211	1,2	125,69	H043	63C	6	6600
6,0	226	1,9	134,76	H053	63C	6	8000
5,8	233	1,1	138,71	HA53	63C	6	6000
5,8	233	1,8	138,71	HA63	63C	6	8000
5,7	238	1,1	142,04	H043	63C	6	6600
5,1	264	1,6	157,29	H053	63C	6	8000
5,0	274	1,5	163,05	HA63	63C	6	8000
4,2	327	1,3	194,56	H053	63C	6	8000
4,0	336	1,2	200,27	HA63	63C	6	8000
3,7	363	1,2	216,38	H053	63C	6	8000
3,4	395	1,0	235,41	HA63	63C	6	8000

0,18 kW

n2 [rpm]	M2 [Nm]	fs	i	Gear reducer	Size	Motor Pole	Fr2 [N]
315,6	5	3,4	4,21	HA31	63B	4	735
305,7	6	3,1	2,94	HA31	71A	6	743
283,3	6	2,9	3,18	HA31	71A	6	762
280,0	6	3,2	4,75	HA31	63B	4	765
268,1	6	2,7	3,36	HA31	71A	6	776
260,8	6	3,1	5,10	HA31	63B	4	783
243,8	7	2,9	5,45	HA31	63B	4	801
232,8	7	2,5	3,87	HA31	71A	6	813
213,6	8	2,3	4,21	HA31	71A	6	837
211,1	8	2,5	6,30	HA31	63B	4	840
189,5	9	2,1	4,75	HA31	71A	6	871
189,5	9	2,9	4,75	HA41	71A	6	881
176,5	10	2,1	5,10	HA31	71A	6	892
168,9	10	1,9	7,88	HA31	63B	4	905
168,9	10	2,1	7,88	HA41	63B	4	915
165,0	10	2,0	5,45	HA31	71A	6	912
165,0	10	2,5	5,45	HA41	71A	6	922
142,9	12	1,7	6,30	HA31	71A	6	957
122,8	14	1,3	10,83	HA41	63B	4	1018
122,8	14	1,5	10,83	HA51	63B	4	2805
117,4	14	3,0	7,67	HRO41	71A	6	1000
114,3	15	1,3	7,88	HA31	71A	6	1031

6.1 H/HA GEARED MOTORS (50Hz)

0,18 kW

n2 [rpm]	M2 [Nm]	fs	i	Gear reducer	Size	Motor Pole	Fr2 [N]
114,3	15	1,4	7,88	HA41	71A	6	1042
114,3	15	2,3	7,88	HA51	71A	6	2873
102,9	16	2,9	8,75	HR041	71A	6	1000
83,1	20	1,0	10,83	HA51	71A	6	3000
80,7	20	2,8	16,49	HA32	63B	4	1620
67,9	25	2,4	13,25	HA32	71A	6	1716
65,6	25	2,6	20,26	HA32	63B	4	1735
54,6	31	1,9	16,49	HA32	71A	6	1845
54,2	30	2,0	24,55	HA32	63B	4	1850
44,4	38	1,7	20,26	HA32	71A	6	1976
43,5	38	1,8	30,55	HA32	63B	4	1990
43,5	38	3,2	30,55	HA42	63B	4	4189
37,5	44	1,8	35,44	HA32	63B	4	2000
37,5	44	2,9	35,44	HA42	63B	4	4300
36,7	45	1,3	24,55	HA32	71A	6	2000
36,7	45	2,5	24,55	HA42	71A	6	4300
30,3	55	2,7	29,70	H032	71A	6	5500
30,2	55	1,4	44,10	HA32	63B	4	2000
30,2	55	2,2	44,10	HA42	63B	4	4300
29,5	57	1,2	30,55	HA32	71A	6	2000
29,5	57	2,1	30,55	HA42	71A	6	4300
27,4	61	2,8	32,89	H032	71A	6	5500
27,3	60	1,1	48,75	HA32	63B	4	2000
27,3	60	1,8	48,75	HA42	63B	4	4300
25,9	62	1,3	51,32	HA33	63B	4	2000
25,9	62	2,1	51,32	HA43	63B	4	4300
25,4	66	1,2	35,44	HA32	71A	6	2000
25,4	66	2,0	35,44	HA42	71A	6	4300
24,8	65	2,6	53,59	H033	63B	4	5500
23,7	70	2,4	37,92	H032	71A	6	5500
22,3	72	1,2	59,65	HA33	63B	4	2000
22,3	72	1,8	59,65	HA43	63B	4	4300
21,9	75	1,1	60,67	HA32	63B	4	2000
21,9	75	1,6	60,67	HA42	63B	4	4300
21,7	77	2,2	41,40	H032	71A	6	5500
21,5	75	3,4	61,83	H043	63B	4	6600
20,6	81	2,9	43,75	H042	71A	6	6600
20,4	82	1,5	44,10	HA42	71A	6	4300
19,9	81	2,1	66,78	H033	63B	4	5500
19,0	88	2,0	47,25	H032	71A	6	5500
18,9	88	2,7	47,53	H042	71A	6	6600
18,5	90	1,2	48,75	HA42	71A	6	4300

6.1 H/HA GEARED MOTORS (50Hz)

0,18 kW

n2 [rpm]	M2 [Nm]	fs	i	Gear reducer	Size	Motor Pole	Fr2 [N]
18,4	88	1,4	72,27	HA43	63B	4	4300
18,1	90	2,8	49,80	HA53	71A	6	6000
17,8	91	1,9	74,84	H033	63B	4	5500
17,8	91	2,8	74,88	HA53	63B	4	6000
17,5	93	1,4	51,32	HA43	71A	6	4300
17,3	93	2,7	76,67	H043	63B	4	6600
16,8	97	1,7	53,59	H033	71A	6	5500
16,6	100	2,4	54,25	H042	71A	6	6600
15,3	106	2,4	87,05	H043	63B	4	6600
15,1	108	1,2	59,65	HA43	71A	6	4300
15,1	107	2,4	88,02	HA53	63B	4	6000
14,9	109	2,3	60,25	HA53	71A	6	6000
14,8	112	1,1	60,67	HA42	71A	6	4300
14,8	109	1,2	89,94	HA43	63B	4	4300
14,6	112	2,3	61,83	H043	71A	6	6600
13,5	121	1,4	66,78	H033	71A	6	5500
13,4	121	1,4	99,27	H033	63B	4	5500
12,4	132	3,2	72,75	H053	71A	6	8000
12,3	131	1,3	108,05	H033	63B	4	5500
12,2	132	3,2	108,95	H053	63B	4	8000
12,0	136	1,3	74,84	H033	71A	6	5500
12,0	136	1,9	74,88	HA53	71A	6	6000
12,0	136	3,0	74,88	HA63	71A	6	8000
11,9	136	1,9	111,61	HA53	63B	4	6000
11,9	136	3,0	111,61	HA63	63B	4	8000
11,7	139	1,8	76,67	H043	71A	6	6600
11,6	139	1,8	114,55	H043	63B	4	6600
10,8	150	1,1	123,71	H033	63B	4	5500
10,6	153	1,7	125,69	H043	63B	4	6600
10,3	158	1,6	87,05	H043	71A	6	6600
10,2	160	1,6	88,02	HA53	71A	6	6000
10,2	160	2,6	88,02	HA63	71A	6	8000
9,9	164	2,6	90,51	H053	71A	6	8000
9,9	164	2,6	134,76	H053	63B	4	8000
9,6	169	1,5	138,71	HA53	63B	4	6000
9,6	169	2,4	138,71	HA63	63B	4	8000
9,4	173	1,5	142,04	H043	63B	4	6600
8,5	191	2,3	157,29	H053	63B	4	8000
8,3	198	2,2	108,95	H053	71A	6	8000
8,2	198	1,3	163,05	HA53	63B	4	6000
8,2	198	2,1	163,05	HA63	63B	4	8000
8,1	202	1,3	111,61	HA53	71A	6	6000

6.1 H/HA GEARED MOTORS (50Hz)

0,18 kW

n2 [rpm]	M2 [Nm]	fs	i	Gear reducer	Size	Motor Pole	Fr2 [N]
8,1	202	2,0	111,61	HA63	71A	6	8000
8,0	201	1,3	165,38	H043	63B	4	6600
7,9	208	1,2	114,55	H043	71A	6	6600
7,2	228	1,1	125,69	H043	71A	6	6600
6,8	236	1,8	194,56	H053	63B	4	8000
6,7	244	1,8	134,76	H053	71A	6	8000
6,6	246	3,0	135,40	H063	71A	6	12000
6,6	243	1,0	200,27	HA53	63B	4	6000
6,6	243	1,7	200,27	HA63	63B	4	8000
6,5	249	1,0	205,07	H043	63B	4	6600
6,5	252	1,0	138,71	HA53	71A	6	6000
6,5	252	1,6	138,71	HA63	71A	6	8000
6,1	263	1,6	216,38	H053	63B	4	8000
6,0	271	2,7	149,51	H063	71A	6	12000
5,7	285	1,5	157,29	H053	71A	6	8000
5,6	286	1,4	235,41	HA63	63B	4	8000
5,5	296	1,4	163,05	HA63	71A	6	8000
5,3	309	2,3	170,67	H063	71A	6	12000
5,0	325	1,3	267,65	H053	63B	4	8000
4,8	338	2,1	186,18	H063	71A	6	12000
4,7	346	1,2	284,81	HA63	63B	4	8000
4,6	353	1,2	194,56	H053	71A	6	8000
4,5	363	1,1	200,27	HA63	71A	6	8000
4,2	392	1,1	216,38	H053	71A	6	8000
4,2	390	1,9	215,21	H063	71A	6	12000
3,8	426	1,7	234,67	H063	71A	6	12000
3,4	486	1,5	268,00	H063	71A	6	12000

0,22 kW

n2 [rpm]	M2 [Nm]	fs	i	Gear reducer	Size	Motor Pole	Fr2 [N]
396,2	5	3,3	3,36	HA31	63C	4	681
344,0	6	3,0	3,87	HA31	63C	4	714
315,6	6	2,8	4,21	HA31	63C	4	735
280,0	7	2,6	4,75	HA31	63C	4	765
260,8	8	2,6	5,10	HA31	63C	4	783
243,8	8	2,4	5,45	HA31	63C	4	801
243,8	8	3,1	5,45	HA41	63C	4	810
211,1	10	2,1	6,30	HA31	63C	4	840
168,9	12	1,6	7,88	HA31	63C	4	905
168,9	12	1,7	7,88	HA41	63C	4	915
168,9	12	2,8	7,88	HA51	63C	4	2522

6.1 H/HA GEARED MOTORS (50Hz)

0,22 kW

n2 [rpm]	M2 [Nm]	fs	i	Gear reducer	Size	Motor Pole	Fr2 [N]
122,8	17	1,0	10,83	HA41	63C	4	1018
122,8	17	1,3	10,83	HA51	63C	4	2805
100,4	20	2,9	13,25	HA32	63C	4	1506
80,7	25	2,3	16,49	HA32	63C	4	1620
65,6	31	2,1	20,26	HA32	63C	4	1735
54,2	37	1,6	24,55	HA32	63C	4	1850
43,5	46	1,5	30,55	HA32	63C	4	1990
43,5	46	2,6	30,55	HA42	63C	4	4189
37,5	54	1,4	35,44	HA32	63C	4	2000
37,5	54	2,4	35,44	HA42	63C	4	4300
30,2	67	1,2	44,10	HA32	63C	4	2000
30,2	67	1,8	44,10	HA42	63C	4	4300
27,3	74	1,5	48,75	HA42	63C	4	4300
25,9	76	1,1	51,32	HA33	63C	4	2000
25,9	76	1,7	51,32	HA43	63C	4	4300
24,8	80	2,1	53,59	H033	63C	4	5500
22,3	89	1,4	59,65	HA43	63C	4	4300
22,1	89	2,9	60,25	HA53	63C	4	6000
21,9	92	1,3	60,67	HA42	63C	4	4300
21,5	92	2,8	61,83	H043	63C	4	6600
19,9	99	1,7	66,78	H033	63C	4	5500
18,4	107	1,2	72,27	HA43	63C	4	4300
17,8	111	1,5	74,84	H033	63C	4	5500
17,8	111	2,3	74,88	HA53	63C	4	6000
17,3	114	2,2	76,67	H043	63C	4	6600
15,3	129	2,0	87,05	H043	63C	4	6600
15,1	131	1,9	88,02	HA53	63C	4	6000
15,1	131	3,1	88,02	HA63	63C	4	8000
14,7	134	3,2	90,51	H053	63C	4	8000
13,4	147	1,1	99,27	H033	63C	4	5500
12,3	160	1,1	108,05	H033	63C	4	5500
12,2	162	2,6	108,95	H053	63C	4	8000
11,9	166	1,5	111,61	HA53	63C	4	6000
11,9	166	2,5	111,61	HA63	63C	4	8000
11,6	170	1,5	114,55	H043	63C	4	6600
10,6	187	1,4	125,69	H043	63C	4	6600
9,9	200	2,1	134,76	H053	63C	4	8000
9,6	206	1,3	138,71	HA53	63C	4	6000
9,6	206	2,0	138,71	HA63	63C	4	8000
9,4	211	1,2	142,04	H043	63C	4	6600
8,5	234	1,8	157,29	H053	63C	4	8000
8,2	242	1,1	163,05	HA53	63C	4	6000

6.1 H/HA GEARED MOTORS (50Hz)

0,22 kW

n2 [rpm]	M2 [Nm]	fs	i	Gear reducer	Size	Motor	Pole	Fr2 [N]
8,2	242	1,7	163,05	HA63	63C		4	8000
8,0	246	1,0	165,38	H043	63C		4	6600
6,8	289	1,5	194,56	H053	63C		4	8000
6,6	297	1,4	200,27	HA63	63C		4	8000
6,1	321	1,3	216,38	H053	63C		4	8000
5,6	350	1,2	235,41	HA63	63C		4	8000
5,0	397	1,1	267,65	H053	63C		4	8000

0,25 kW

n2 [rpm]	M2 [Nm]	fs	i	Gear reducer	Size	Motor	Pole	Fr2 [N]
448,3	5	3,3	2,94	HA31	63D		4	654
415,6	6	3,1	3,18	HA31	63D/71A		4	670
393,2	6	2,9	3,36	HA31	63D/71A		4	683
352,9	7	2,4	2,55	HA31	71B		6	708
341,4	7	2,7	3,87	HA31	63D/71A		4	716
313,2	7	2,4	4,21	HA31	63D/71A		4	737
305,7	8	2,2	2,94	HA31	71B		6	743
305,7	8	2,7	2,94	HA41	71B		6	751
283,3	8	2,1	3,18	HA31	71B		6	762
277,9	8	2,3	4,75	HA31	63D/71A		4	767
277,9	8	3,1	4,75	HA41	63D/71A		4	775
268,1	9	1,9	3,36	HA31	71B		6	776
258,8	9	2,2	5,10	HA31	63D/71A		4	785
242,0	10	2,1	5,45	HA31	63D/71A		4	803
242,0	10	2,7	5,45	HA41	63D/71A		4	812
232,8	10	1,8	3,87	HA31	71B		6	813
213,6	11	1,6	4,21	HA31	71B		6	837
209,5	11	1,8	6,30	HA31	63D/71A		4	842
189,5	12	1,5	4,75	HA31	71B		6	871
189,5	12	2,1	4,75	HA41	71B		6	881
181,3	13	3,4	7,67	HR041	71A		4	1000
180,0	13	2,9	5,00	HR041	71B		6	1000
176,5	13	1,5	5,10	HA31	71B		6	892
167,6	14	1,4	7,88	HA31	63D/71A		4	907
167,6	14	1,5	7,88	HA41	63D/71A		4	918
167,6	14	2,5	7,88	HA51	63D/71A		4	2528
165,0	14	1,4	5,45	HA31	71B		6	912
165,0	14	1,8	5,45	HA41	71B		6	922
165,0	14	3,0	5,45	HA51	71B		6	2542
163,6	14	3,0	5,50	HR041	71B		6	1000
158,9	15	3,2	8,75	HR041	71A		4	1000

6.1 H/HA GEARED MOTORS (50Hz)

0,25 kW

n ₂ [rpm]	M ₂ [Nm]	f _s	i	Gear reducer	Size	Motor Pole	Fr ₂ [N]
147,8	16	2,7	6,09	HR041	71B	6	1000
142,9	16	1,2	6,30	HA31	71B	6	957
121,8	19	1,1	10,83	HA51	63D/71A	4	2812
117,4	20	2,2	7,67	HR041	71B	6	1000
114,3	20	1,0	7,88	HA41	71B	6	1042
114,3	20	1,7	7,88	HA51	71B	6	2873
111,0	21	2,6	8,11	HA32	71B	6	1457
102,9	23	2,1	8,75	HR041	71B	6	1000
99,6	23	2,5	13,25	HA32	63D/71A	4	1510
82,3	28	2,3	10,94	HA32	71B	6	1609
80,1	29	2,0	16,49	HA32	63D/71A	4	1624
67,9	34	1,7	13,25	HA32	71B	6	1716
65,2	35	1,8	20,26	HA32	63D/71A	4	1740
54,6	42	1,4	16,49	HA32	71B	6	1845
54,6	42	2,4	16,49	HA42	71B	6	3885
53,8	43	1,4	24,55	HA32	63D/71A	4	1854
53,8	43	2,6	24,55	HA42	63D/71A	4	3904
44,4	52	1,2	20,26	HA32	71B	6	1976
44,4	52	2,1	20,26	HA42	71B	6	4161
43,2	53	1,3	30,55	HA32	63D/71A	4	1995
43,2	53	2,3	30,55	HA42	63D/71A	4	4199
42,3	54	3,2	32,89	H032	71A	4	5500
39,7	58	2,5	22,68	H032	71B	6	5500
37,8	61	2,4	23,83	H032	71B	6	5500
37,2	62	1,3	35,44	HA32	63D/71A	4	2000
37,2	62	2,1	35,44	HA42	63D/71A	4	4300
36,7	63	2,7	37,92	H032	71A	4	5500
36,7	63	1,8	24,55	HA42	71B	6	4300
34,1	68	2,1	26,39	H032	71B	6	5500
33,6	68	2,5	41,40	H032	71A	4	5500
31,8	72	3,3	43,75	H042	71A	4	6600
30,3	76	1,9	29,70	H032	71B	6	5500
29,9	77	1,0	44,10	HA32	63D/71A	4	2000
29,9	77	1,6	44,10	HA42	63D/71A	4	4300
29,6	78	3,0	30,45	H042	71B	6	6600
29,5	79	1,5	30,55	HA42	71B	6	4300
29,4	78	2,2	47,25	H032	71A	4	5500
29,2	78	3,0	47,53	H042	71A	4	6600
27,4	85	2,0	32,89	H032	71B	6	5500
27,1	83	1,0	51,32	HA33	71A	4	2000
27,1	85	1,3	48,75	HA42	63D/71A	4	4300
26,5	85	3,0	49,80	HA53	63D/71A	4	6000

6.1 H/HA GEARED MOTORS (50Hz)

0,25 kW

n2 [rpm]	M2 [Nm]	fs	i	Gear reducer	Size	Motor Pole	Fr2 [N]
26,4	88	2,7	34,10	H042	71B	6	6600
25,7	87	1,5	51,32	HA43	63D/71A	4	4300
25,6	89	2,7	54,25	H042	71A	4	6600
25,4	91	1,4	35,44	HA42	71B	6	4300
24,6	91	1,9	53,59	H033	63D/71A	4	5500
23,8	97	2,5	37,76	H042	71B	6	6600
23,7	98	1,8	37,92	H032	71B	6	5500
22,1	101	1,3	59,65	HA43	63D/71A	4	4300
21,9	102	2,5	60,25	HA53	63D/71A	4	6000
21,8	105	1,1	60,67	HA42	63D/71A	4	4300
21,7	106	1,6	41,40	H032	71B	6	5500
21,3	105	2,4	61,83	H043	63D/71A	4	6600
20,6	113	2,1	43,75	H042	71B	6	6600
20,4	113	1,1	44,10	HA42	71B	6	4300
19,8	114	1,5	66,78	H033	63D/71A	4	5500
19,0	122	1,4	47,25	H032	71B	6	5500
18,9	122	1,9	47,53	H042	71B	6	6600
18,3	123	1,0	72,27	HA43	63D/71A	4	4300
18,1	125	2,0	49,80	HA53	71B	6	6000
17,6	127	1,4	74,84	H033	63D/71A	4	5500
17,6	127	2,0	74,88	HA53	63D/71A	4	6000
17,6	127	3,2	74,88	HA63	63D/71A	4	8000
17,2	130	2,0	76,67	H043	63D/71A	4	6600
16,8	135	1,3	53,59	H033	71B	6	5500
16,6	140	1,7	54,25	H042	71B	6	6600
16,0	144	2,9	56,11	H052	71B	6	8000
15,3	148	2,9	58,81	H053	71B	6	8000
15,2	148	1,7	87,05	H043	63D/71A	4	6600
15,0	150	1,7	88,02	HA53	63D/71A	4	6000
15,0	150	2,7	88,02	HA63	63D/71A	4	8000
14,9	152	1,7	60,25	HA53	71B	6	6000
14,9	152	2,7	60,25	HA63	71B	6	8000
14,6	156	1,6	61,83	H043	71B	6	6600
14,6	154	2,8	90,51	H053	63D/71A	4	8000
13,5	168	1,0	66,78	H033	71B	6	5500
13,3	169	1,0	99,27	H033	63D/71A	4	5500
12,4	183	2,3	72,75	H053	71B	6	8000
12,1	185	2,3	108,95	H053	63D/71A	4	8000
12,0	189	1,3	74,88	HA53	71B	6	6000
12,0	189	2,2	74,88	HA63	71B	6	8000
11,8	190	1,3	111,61	HA53	63D/71A	4	6000
11,8	190	2,2	111,61	HA63	63D/71A	4	8000

6.1 H/HA GEARED MOTORS (50Hz)

0,25 kW

n2 [rpm]	M2 [Nm]	fs	i	Gear reducer	Size	Motor Pole	Fr2 [N]
11,7	193	1,3	76,67	H043	71B	6	6600
11,5	195	1,3	114,55	H043	63D/71A	4	6600
10,5	214	1,2	125,69	H043	63D/71A	4	6600
10,3	219	1,2	87,05	H043	71B	6	6600
10,3	219	3,3	135,40	H063	71A	4	12000
10,2	222	1,1	88,02	HA53	71B	6	6000
10,2	222	1,8	88,02	HA63	71B	6	8000
9,9	228	1,9	90,51	H053	71B	6	8000
9,8	229	1,9	134,76	H053	63D/71A	4	8000
9,5	239	3,0	94,76	H063	71B	6	12000
9,5	236	1,1	138,71	HA53	63D/71A	4	6000
9,5	236	1,7	138,71	HA63	63D/71A	4	8000
9,3	241	1,1	142,04	H043	63D/71A	4	6600
9,3	241	3,0	149,51	H063	71A	4	12000
8,4	267	1,6	157,29	H053	63D/71A	4	8000
8,3	274	1,6	108,95	H053	71B	6	8000
8,1	276	2,6	170,67	H063	71A	4	12000
8,1	281	1,5	111,61	HA63	71B	6	8000
8,1	277	1,5	163,05	HA63	63D/71A	4	8000
7,6	297	2,4	118,00	H063	71B	6	12000
7,5	301	2,4	186,18	H063	71A	4	12000
6,8	331	1,3	194,56	H053	63D/71A	4	8000
6,7	339	1,3	134,76	H053	71B	6	8000
6,6	341	2,1	135,40	H063	71B	6	12000
6,6	340	1,2	200,27	HA63	63D/71A	4	8000
6,5	347	2,1	215,21	H063	71A	4	12000
6,5	349	1,2	138,71	HA63	71B	6	8000
6,1	368	1,2	216,38	H053	63D/71A	4	8000
6,0	377	1,9	149,51	H063	71B	6	12000
5,9	379	1,9	234,67	H063	71A	4	12000
5,7	396	1,1	157,29	H053	71B	6	8000
5,6	400	1,0	235,41	HA63	63D/71A	4	8000
5,3	430	1,7	170,67	H063	71B	6	12000
5,2	433	1,7	268,00	H063	71A	4	12000
4,8	469	1,5	186,18	H063	71B	6	12000
4,2	542	1,3	215,21	H063	71B	6	12000
3,8	591	1,2	234,67	H063	71B	6	12000
3,4	675	1,1	268,00	H063	71B	6	12000

0,37 kW

n2 [rpm]	M2 [Nm]	fs	i	Gear reducer	Size	Motor	Pole	Fr2 [N]
541,2	6	2,5	2,55	HA31	71B		4	614
468,7	7	2,3	2,94	HA31	71B		4	644
468,7	7	2,9	2,94	HA41	71B		4	651
440,0	8	2,7	2,00	HR041	71C/80A		6	948
434,4	8	2,2	3,18	HA31	71B		4	661
411,1	8	2,0	3,36	HA31	71B		4	673
356,9	10	1,9	3,87	HA31	71B		4	705
345,7	10	2,6	2,55	HR041	71C/80A		6	1000
345,1	10	1,6	2,55	HA31	71C/80A		6	713
327,5	10	1,7	4,21	HA31	71B		4	726
324,2	11	2,4	2,71	HR041	71C/80A		6	1000
298,9	12	1,5	2,94	HA31	71C/80A		6	748
298,9	12	1,8	2,94	HA41	71C/80A		6	757
298,9	12	2,9	2,94	HA51	71C/80A		6	2085
290,5	12	1,6	4,75	HA31	71B		4	755
290,5	12	2,2	4,75	HA41	71B		4	764
283,4	12	2,8	3,11	HR041	71C		6	1000
277,0	12	1,4	3,18	HA31	71C/80A		6	767
276,0	12	3,1	5,00	HR041	71B		4	1000
270,6	13	1,6	5,10	HA31	71B		4	773
262,1	13	1,3	3,36	HA31	71C/80A		6	782
253,0	14	1,5	5,45	HA31	71B		4	791
253,0	14	1,9	5,45	HA41	71B		4	800
253,0	14	3,2	5,45	HA51	71B		4	2204
250,9	14	3,1	5,50	HR041	71B		4	1000
245,2	14	2,7	3,59	HR041	71C/80A		6	1000
227,6	15	1,2	3,87	HA31	71C/80A		6	819
226,6	15	2,8	6,09	HR041	71B		4	1000
219,0	16	1,3	6,30	HA31	71B		4	830
209,5	17	2,3	4,20	HR041	71C/80A		6	1000
208,8	17	1,1	4,21	HA31	71C/80A		6	843
185,3	19	1,0	4,75	HA31	71C/80A		6	878
185,3	19	1,4	4,75	HA41	71C/80A		6	887
185,3	19	2,3	4,75	HA51	71C/80A		6	2445
180,0	19	2,3	7,67	HR041	71B		4	1000
176,0	20	1,9	5,00	HR041	71C/80A		6	1000
175,2	20	1,1	7,88	HA41	71B		4	904
175,2	20	1,7	7,88	HA51	71B		4	2491
170,2	20	2,7	8,11	HA32	71B		4	1263
161,3	21	1,2	5,45	HA41	71C/80A		6	929
161,3	21	2,0	5,45	HA51	71C/80A		6	2561
160,0	22	2,0	5,50	HR041	71C/80A		6	1000

6.1 H/HA GEARED MOTORS (50Hz)

0,37 kW

n2 [rpm]	M2 [Nm]	fs	i	Gear reducer	Size	Motor Pole	Fr2 [N]
157,7	22	2,2	8,75	HR041	71B	4	1000
144,5	24	1,8	6,09	HR041	71C/80A	6	1000
135,0	25	2,3	6,52	HA32	71C/80A	6	1364
126,2	27	2,4	10,94	HA32	71B	4	1396
121,3	29	2,7	7,75	HA61	80A	6	4215
120,0	29	2,9	7,33	HR051	71C/80A	6	2500
114,8	30	1,4	7,67	HR041	71C/80A	6	1000
111,7	31	1,1	7,88	HA51	71C	6	2894
108,5	32	1,7	8,11	HA32	71C/80A	6	1468
105,1	33	2,6	8,38	HR051	71C/80A	6	2500
104,2	33	1,8	13,25	HA32	71B	4	1488
100,6	34	1,4	8,75	HR041	71C/80A	6	1000
99,2	35	2,7	8,87	H032	71C	6	5404
88,1	39	1,5	10,67	HA61	80A	6	4500
86,8	39	2,6	10,14	H032	71C/80A	6	5500
83,7	41	1,4	16,49	HA32	71B	4	1600
83,7	41	2,5	16,49	HA42	71B	4	3369
80,5	43	1,5	10,94	HA32	71C/80A	6	1621
80,5	43	2,5	10,94	HA42	71C/80A	6	3413
74,8	46	2,3	11,76	H032	71C/80A	6	5500
68,1	50	1,3	20,26	HA32	71B	4	1714
68,1	50	2,2	20,26	HA42	71B	4	3608
66,4	52	1,1	13,25	HA32	71C/80A	6	1728
66,4	52	2,0	13,25	HA42	71C/80A	6	3639
64,1	53	2,3	13,72	H032	71C/80A	6	5500
60,8	56	2,6	22,68	H032	71B	4	5500
60,0	57	2,2	14,66	H032	71C/80A	6	5500
57,9	59	2,5	23,83	H032	71B	4	5500
56,2	60	1,0	24,55	HA32	71B	4	1827
56,2	60	1,9	24,55	HA42	71B	4	3847
53,4	64	1,6	16,49	HA42	71C/80A	6	3914
52,5	65	2,1	16,77	H032	71C/80A	6	5500
52,3	65	2,2	26,39	H032	71B	4	5500
48,4	71	2,0	18,20	H032	71C/80A	6	5500
46,5	73	2,0	29,70	H032	71B	4	5500
46,3	74	2,4	19,00	H042	71C/80A	6	6600
45,3	75	3,2	30,45	H042	71B	4	6600
45,2	75	1,6	30,55	HA42	71B	4	4138
44,2	77	1,9	19,90	H032	71C/80A	6	5500
43,4	79	1,4	20,26	HA42	71C/80A	6	4192
42,0	81	2,1	32,89	H032	71B	4	5500
41,9	82	2,2	21,00	H042	71C/80A	6	6600

6.1 H/HA GEARED MOTORS (50Hz)

0,37 kW

n2 [rpm]	M2 [Nm]	fs	i	Gear reducer	Size	Motor Pole	Fr2 [N]
40,5	84	2,8	34,10	H042	71B	4	6600
38,9	87	1,5	35,44	HA42	71B	4	4300
38,8	88	1,6	22,68	H032	71C/80A	6	5500
38,0	90	2,1	23,15	H042	71C/80A	6	6600
37,0	93	2,2	25,43	HA52	80A	6	5530
36,9	93	1,6	23,83	H032	71C/80A	6	5500
36,5	93	2,6	37,76	H042	71B	4	6600
36,4	93	1,8	37,92	H032	71B	4	5500
35,9	96	1,2	24,55	HA42	71C/80A	6	4300
33,8	101	1,9	26,04	H042	71C/80A	6	6600
33,3	103	1,4	26,39	H032	71C/80A	6	5500
33,3	102	1,7	41,40	H032	71B	4	5500
32,0	107	1,9	27,50	H042	71C/80A	6	6600
31,5	108	2,2	43,75	H042	71B	4	6600
31,4	109	2,0	29,89	HA52	80A	6	5836
31,3	108	1,1	44,10	HA42	71B	4	4300
29,6	116	1,3	29,70	H032	71C/80A	6	5500
29,2	116	1,5	47,25	H032	71B	4	5500
29,0	117	2,0	47,53	H042	71B	4	6600
28,9	119	2,0	30,45	H042	71C/80A	6	6600
28,8	119	1,0	30,55	HA42	71C/80A	6	4300
27,7	120	2,1	49,80	HA53	71B	4	6000
26,9	124	1,0	51,32	HA43	71B	4	4300
26,8	128	1,3	32,89	H032	71C/80A	6	5500
26,0	132	1,9	36,17	HA52	80A	6	6000
26,0	132	3,0	36,17	HA62	80A	6	8000
25,8	129	1,3	53,59	H033	71B	4	5500
25,8	133	1,8	34,10	H042	71C/80A	6	6600
25,4	133	1,8	54,25	H042	71B	4	6600
24,6	138	3,0	56,11	H052	71B	4	8000
23,5	142	3,0	58,81	H053	71B	4	8000
23,3	147	1,6	37,76	H042	71C/80A	6	6600
23,2	148	1,2	37,92	H032	71C/80A	6	5500
22,9	145	1,8	60,25	HA53	71B	4	6000
22,9	145	2,8	60,25	HA63	71B	4	8000
22,6	152	2,8	38,98	H052	71C/80A	6	8000
22,3	149	1,7	61,83	H043	71B	4	6600
21,3	161	1,1	41,40	H032	71C/80A	6	5500
20,9	164	1,5	44,95	HA52	80A	6	6000
20,9	164	2,3	44,95	HA62	80A	6	8000
20,7	161	1,1	66,78	H033	71B	4	5500
20,1	170	1,4	43,75	H042	71C/80A	6	6600

6.1 H/HA GEARED MOTORS (50Hz)

0,37 kW

n2 [rpm]	M2 [Nm]	fs	i	Gear reducer	Motor Size	Pole	Fr2 [N]
19,4	177	2,4	45,36	H052	71C/80A	6	8000
19,0	175	2,4	72,75	H053	71B	4	8000
18,9	181	1,4	49,78	HA52	80A	6	6000
18,9	181	1,7	49,78	HA62	80A	6	8000
18,5	185	1,3	47,53	H042	71C/80A	6	6600
18,4	180	1,4	74,88	HA53	71B	4	6000
18,4	180	2,3	74,88	HA63	71B	4	8000
18,0	185	1,4	76,67	H043	71B	4	6600
17,9	191	2,2	49,13	H052	71C/80A	6	8000
17,7	190	1,3	49,80	HA53	71C/80A	6	6000
17,7	190	2,1	49,80	HA63	71C/80A	6	8000
16,2	211	1,1	54,25	H042	71C/80A	6	6600
15,9	210	1,2	87,05	H043	71B	4	6600
15,7	218	1,9	56,11	H052	71C/80A	6	8000
15,7	212	1,2	88,02	HA53	71B	4	6000
15,7	212	1,9	88,02	HA63	71B	4	8000
15,2	218	2,0	90,51	H053	71B	4	8000
15,2	225	1,1	61,87	HA52	80A	6	6000
15,2	225	1,7	61,87	HA62	80A	6	8000
15,0	224	1,9	58,81	H053	71C/80A	6	8000
14,6	228	3,2	94,76	H063	71B	4	12000
14,6	230	1,1	60,25	HA53	71C/80A	6	6000
14,6	230	1,8	60,25	HA63	71C/80A	6	8000
14,2	236	1,1	61,83	H043	71C/80A	6	6600
12,7	262	1,6	108,95	H053	71B	4	8000
12,4	269	1,5	111,61	HA63	71B	4	8000
12,1	277	1,5	72,75	H053	71C/80A	6	8000
11,8	285	1,4	74,88	HA63	71C/80A	6	8000
11,7	284	2,5	118,00	H063	71B	4	12000
10,3	327	2,2	85,82	H063	71C/80A	6	12000
10,2	324	1,3	134,76	H053	71B	4	8000
10,2	326	2,2	135,40	H063	71B	4	12000
10,0	336	1,2	88,02	HA63	71C/80A	6	8000
9,9	334	1,2	138,71	HA63	71B	4	8000
9,7	345	1,2	90,51	H053	71C/80A	6	8000
9,3	361	2,0	94,76	H063	71C/80A	6	12000
9,2	360	2,0	149,51	H063	71B	4	12000
8,8	379	1,1	157,29	H053	71B	4	8000
8,5	392	1,0	163,05	HA63	71B	4	8000
8,4	398	1,0	111,61	HA63	80A	6	8000
8,1	415	1,0	108,95	H053	71C/80A	6	8000
8,1	411	1,8	170,67	H063	71B	4	12000

6.1 H/HA GEARED MOTORS (50Hz)

0,37 kW

n2 [rpm]	M2 [Nm]	fs	i	Gear reducer	Motor Size	Pole	Fr2 [N]
7,5	450	1,6	118,00	H063	71C/80A	6	12000
7,4	448	1,6	186,18	H063	71B	4	12000
6,6	507	3,0	142,15	H083	80A	6	18000
6,5	516	1,4	135,40	H063	71C/80A	6	12000
6,4	518	1,4	215,21	H063	71B	4	12000
6,1	552	2,8	154,76	H083	80A	6	18000
5,9	570	1,3	149,51	H063	71C/80A	6	12000
5,9	565	1,3	234,67	H063	71B	4	12000
5,8	579	2,6	162,35	H083	80A	6	18000
5,2	651	1,1	170,67	H063	71C/80A	6	12000
5,2	639	2,4	179,13	H083	80A	6	18000
5,1	645	1,1	268,00	H063	71B	4	12000
4,8	696	2,2	195,07	H083	80A	6	18000
4,7	710	1,0	186,18	H063	71C/80A	6	12000
4,2	795	1,9	222,78	H083	80A	6	18000

0,55 kW

n2 [rpm]	M2 [Nm]	fs	i	Gear reducer	Motor Size	Pole	Fr2 [N]
685,0	7	2,8	2,00	HR041	71C/80A	4	816
647,0	8	2,6	1,44	HR041	80B	6	830
642,1	8	2,6	1,45	HA41	80B	6	586
538,2	9	2,7	2,55	HR041	71C/80A	4	877
537,3	9	1,7	2,55	HA31	71C/80A	4	615
504,7	10	2,6	2,71	HR041	71C/80A	4	894
465,3	11	1,6	2,94	HA31	71C/80A	4	646
465,3	11	1,9	2,94	HA41	71C/80A	4	653
465,3	11	3,1	2,94	HA51	71C/80A	4	1799
465,0	11	1,9	2,00	HR041	80B	6	916
441,2	12	2,9	3,11	HR041	71C/80A	4	930
431,3	12	1,4	3,18	HA31	71C/80A	4	662
408,1	12	1,4	3,36	HA31	71C/80A	4	674
381,8	13	2,8	3,59	HR041	71C/80A	4	970
365,4	14	1,8	2,55	HR041	80B	6	982
364,7	14	1,1	2,55	HA31	80B	6	700
354,3	14	1,3	3,87	HA31	71C/80A	4	707
342,6	15	1,7	2,71	HR041	80B	6	1000
326,2	16	2,4	4,20	HR041	71C/80A	4	1000
325,1	16	1,1	4,21	HA31	71C/80A	4	728
315,8	16	1,0	2,94	HA31	80B	6	735
315,8	16	1,3	2,94	HA41	80B	6	743
315,8	16	2,1	2,94	HA51	80B	6	2047

6.1 H/HA GEARED MOTORS (50Hz)

0,55 kW

n2 [rpm]	M2 [Nm]	fs	i	Gear reducer	Size	Motor Pole	Fr2 [N]
299,5	17	2,0	3,11	HR041	80B	6	1000
288,4	18	1,1	4,75	HA31	71C/80A	4	757
288,4	18	1,5	4,75	HA41	71C/80A	4	766
288,4	18	2,4	4,75	HA51	71C/80A	4	2110
274,0	19	2,0	5,00	HR041	71C/80A	4	1000
268,6	19	1,1	5,10	HA31	71C	4	775
259,2	20	1,9	3,59	HR041	80B	6	1000
251,2	20	1,3	5,45	HA41	71C/80A	4	802
251,2	20	2,1	5,45	HA51	71C/80A	4	2209
249,1	20	2,1	5,50	HR041	71C/80A	4	1000
224,9	23	1,9	6,09	HR041	71C/80A	4	1000
221,4	23	1,6	4,20	HR041	80B	6	1000
210,2	24	2,4	6,52	HA32	71C/80A	4	1177
198,0	26	2,7	4,70	H032	80B	6	4321
195,8	26	1,6	4,75	HA51	80B	6	2401
195,0	26	3,1	4,77	HR051	80B	6	2500
186,8	27	3,1	7,33	HR051	71C/80A	4	2500
186,0	28	1,4	5,00	HR041	80B	6	1000
180,6	28	2,7	7,75	HA61	80A	4	3691
178,7	29	1,5	7,67	HR041	71C/80A	4	1000
177,1	29	2,9	5,25	HR051	80B	6	2500
174,0	29	1,2	7,88	HA51	71C	4	2497
172,9	29	2,0	5,38	HA32	80B	6	1256
170,5	30	1,4	5,45	HA51	80B	6	2514
169,1	30	1,4	5,50	HR041	80B	6	1000
168,9	30	1,8	8,11	HA32	71C/80A	4	1266
163,6	31	2,8	8,38	HR051	71C/80A	4	2500
159,8	32	2,6	5,82	HR051	80B	6	2500
156,6	33	1,4	8,75	HR041	71C/80A	4	1000
154,5	33	2,9	8,87	H032	71C	4	4641
152,7	34	1,3	6,09	HR041	80B	6	1000
149,3	34	2,2	6,23	H032	80B	6	4682
142,7	36	1,6	6,52	HA32	80B	6	1339
135,1	37	2,7	10,14	H032	71C/80A	4	4818
131,3	39	1,5	10,67	HA61	80A	4	4106
126,8	41	2,1	7,33	HR051	80B	6	2500
125,3	40	1,6	10,94	HA32	71C/80A	4	1399
125,3	40	2,7	10,94	HA42	71C/80A	4	2945
121,3	42	1,0	7,67	HR041	80B	6	1000
120,0	43	1,8	7,75	HA61	80B	6	4230
119,8	43	2,1	7,76	H032	80B	6	4974
116,5	43	2,4	11,76	H032	71C/80A	4	5016

6.1 H/HA GEARED MOTORS (50Hz)

0,55 kW

n2 [rpm]	M2 [Nm]	fs	i	Gear reducer	Motor Size	Pole	Fr2 [N]
114,7	44	1,2	8,11	HA32	80B	6	1441
114,7	44	2,1	8,11	HA42	80B	6	3033
111,0	46	1,9	8,38	HR051	80B	6	2500
111,0	46	3,1	8,38	HR061	80B	6	3700
104,9	49	1,9	8,87	H032	80B	6	5154
103,4	49	1,2	13,25	HA32	71C/80A	4	1491
103,4	49	2,1	13,25	HA42	71C/80A	4	3140
99,9	50	2,4	13,72	H032	71C/80A	4	5226
93,5	54	2,3	14,66	H032	71C/80A	4	5317
91,7	56	1,8	10,14	H032	80B	6	5338
87,2	59	1,0	10,67	HA61	80B	6	4500
85,0	60	1,1	10,94	HA32	80B	6	1592
85,0	60	1,8	10,94	HA42	80B	6	3351
83,1	61	1,7	16,49	HA42	71C/80A	4	3377
81,7	62	2,2	16,77	H032	71C/80A	4	5500
79,1	64	1,6	11,76	H032	80B	6	5500
75,3	67	2,2	18,20	H032	71C/80A	4	5500
72,1	70	2,6	19,00	H042	71C/80A	4	6600
70,2	73	1,4	13,25	HA42	80B	6	3572
68,9	73	2,0	19,90	H032	71C/80A	4	5500
68,5	74	2,4	13,57	H042	80B	6	6600
68,4	74	2,8	20,46	HA52	80A	4	4504
67,8	75	1,6	13,72	H032	80B	6	5500
67,6	75	1,4	20,26	HA42	71C/80A	4	3617
65,2	77	2,3	21,00	H042	71C/80A	4	6600
64,1	79	2,5	14,50	HA52	80B	6	4602
63,5	80	1,5	14,66	H032	80B	6	5500
60,4	83	1,7	22,68	H032	71C/80A	4	5500
59,2	85	2,2	23,15	H042	71C/80A	4	6600
58,3	87	2,1	15,96	H042	80B	6	6600
57,5	88	1,7	23,83	H032	71C/80A	4	5500
56,4	90	1,1	16,49	HA42	80B	6	3843
55,8	90	1,2	24,55	HA42	71C/80A	4	3856
55,5	92	1,5	16,77	H032	80B	6	5500
55,1	92	2,2	25,43	HA52	80A	4	4842
55,0	93	2,3	16,91	HA52	80B	6	4844
52,6	96	2,0	26,04	H042	71C/80A	4	6600
51,9	97	1,5	26,39	H032	71C/80A	4	5500
51,1	100	1,5	18,20	H032	80B	6	5500
49,8	101	2,0	27,50	H042	71C/80A	4	6600
48,9	104	1,7	19,00	H042	80B	6	6600
46,8	108	2,0	29,89	HA52	80A	4	5110

6.1 H/HA GEARED MOTORS (50Hz)

0,55 kW

n2 [rpm]	M2 [Nm]	fs	i	Gear reducer	Motor Size	Pole	Fr2 [N]
46,7	109	1,3	19,90	H032	80B	6	5500
46,1	109	1,3	29,70	H032	71C/80A	4	5500
45,5	112	1,9	20,46	HA52	80B	6	5162
45,0	112	2,1	30,45	H042	71C/80A	4	6600
44,9	112	1,1	30,55	HA42	71C/80A	4	4148
44,3	115	1,6	21,00	H042	80B	6	6600
41,7	121	1,4	32,89	H032	71C/80A	4	5500
41,0	124	1,2	22,68	H032	80B	6	5500
40,2	127	1,5	23,15	H042	80B	6	6600
40,2	126	1,9	34,10	H042	71C/80A	4	6600
39,0	131	1,1	23,83	H032	80B	6	5500
38,7	130	2,0	36,17	HA52	80A	4	5445
38,7	130	3,1	36,17	HA62	80A	4	8000
37,6	135	2,5	24,71	H052	80B	6	8000
36,6	139	1,5	25,43	HA52	80B	6	5549
36,6	139	2,2	25,43	HA62	80B	6	8000
36,3	139	1,7	37,76	H042	71C/80A	4	6600
36,1	140	1,2	37,92	H032	71C/80A	4	5500
35,7	143	1,3	26,04	H042	80B	6	6600
35,5	143	2,5	26,18	H052	80B	6	8000
35,2	145	1,0	26,39	H032	80B	6	5500
35,1	143	2,9	38,98	H052	71C/80A	4	8000
33,8	151	1,3	27,50	H042	80B	6	6600
33,1	152	1,1	41,40	H032	71C/80A	4	5500
32,7	156	2,3	28,44	H052	80B	6	8000
31,3	161	1,5	43,75	H042	71C/80A	4	6600
31,1	164	1,3	29,89	HA52	80B	6	5857
31,1	162	1,5	44,95	HA52	80A	4	5855
31,1	164	2,0	29,89	HA62	80B	6	8000
31,1	162	2,3	44,95	HA62	80A	4	8000
30,5	167	1,4	30,45	H042	80B	6	6600
30,2	167	2,5	45,36	H052	71C/80A	4	8000
29,6	170	1,0	47,25	H032	80A	4	5500
29,5	173	2,4	31,52	H052	80B	6	8000
28,8	175	1,4	47,53	H042	71C/80A	4	6600
28,2	181	2,3	33,00	H052	80B	6	8000
28,1	179	1,4	49,78	HA52	80A	4	6000
28,1	179	1,8	49,78	HA62	80A	4	8000
27,9	181	2,3	49,13	H052	71C/80A	4	8000
27,5	179	1,4	49,80	HA53	71C/80A	4	6000
27,5	179	2,3	49,80	HA63	71C/80A	4	8000
27,3	187	1,3	34,10	H042	80B	6	6600

6.1 H/HA GEARED MOTORS (50Hz)

0,55 kW

n2 [rpm]	M2 [Nm]	fs	i	Gear reducer	Size	Motor Pole	Fr2 [N]
25,7	198	1,3	36,17	HA52	80B	6	6000
25,7	198	2,0	36,17	HA62	80B	6	8000
25,3	200	1,2	54,25	H042	71C/80A	4	6600
24,6	207	1,2	37,76	H042	80B	6	6600
24,4	207	2,0	56,11	H052	71C/80A	4	8000
23,9	213	2,0	38,98	H052	80B	6	8000
23,3	212	2,0	58,81	H053	71C/80A	4	8000
22,7	217	1,2	60,25	HA53	71C/80A	4	6000
22,7	217	1,9	60,25	HA63	71C/80A	4	8000
22,6	223	1,1	61,87	HA52	80A	4	6000
22,6	223	1,7	61,87	HA62	80A	4	8000
22,2	223	1,1	61,83	H043	71C/80A	4	6600
20,7	246	1,5	44,95	HA62	80B	6	8000
20,5	248	1,7	45,36	H052	80B	6	8000
20,2	252	2,9	46,06	H062	80B	6	12000
18,9	269	1,6	49,13	H052	80B	6	8000
18,8	262	1,6	72,75	H053	71C/80A	4	8000
18,7	273	1,2	49,78	HA62	80B	6	8000
18,7	267	1,5	49,80	HA63	80B	6	8000
18,3	270	1,5	74,88	HA63	71C/80A	4	8000
16,6	307	1,4	56,11	H052	80B	6	8000
16,0	309	2,3	85,82	H063	71C/80A	4	12000
15,8	315	1,4	58,81	H053	80B	6	8000
15,6	317	1,3	88,02	HA63	71C/80A	4	8000
15,4	323	1,3	60,25	HA63	80B	6	8000
15,1	326	1,3	90,51	H053	71C/80A	4	8000
15,0	339	1,1	61,87	HA62	80B	6	8000
14,5	341	2,1	94,76	H063	71C/80A	4	12000
12,8	390	1,1	72,75	H053	80B	6	8000
12,6	393	1,1	108,95	H053	71C/80A	4	8000
12,4	402	1,0	74,88	HA63	80B	6	8000
12,3	402	1,0	111,61	HA63	71C/80A	4	8000
11,6	425	1,7	118,00	H063	71C/80A	4	12000
10,8	460	1,6	85,82	H063	80B	6	12000
10,1	488	1,5	135,40	H063	71C/80A	4	12000
9,8	508	1,4	94,76	H063	80B	6	12000
9,8	501	3,1	142,15	H083	80A	4	18000
9,5	526	2,9	98,09	H083	80B	6	18000
9,2	539	1,3	149,51	H063	71C/80A	4	12000
9,0	546	2,8	154,76	H083	80A	4	18000
8,6	573	2,7	162,35	H083	80A	4	18000
8,2	605	2,5	112,78	H083	80B	6	18000

0,55 kW

n2 [rpm]	M2 [Nm]	fs	i	Gear reducer	Size	Motor Pole	Fr2 [N]
8,0	615	1,2	170,67	H063	71C/80A	4	12000
7,9	633	1,1	118,00	H063	80B	6	12000
7,8	632	2,4	179,13	H083	80A	4	18000
7,5	667	2,3	124,44	H083	80B	6	18000
7,4	671	1,1	186,18	H063	71C/80A	4	12000
7,2	688	2,2	195,07	H083	80A	4	18000
6,5	762	2,0	142,15	H083	80B	6	18000
6,3	786	2,0	222,78	H083	80A	4	18000
6,0	830	1,8	154,76	H083	80B	6	18000
5,7	871	1,8	162,35	H083	80B	6	18000
5,2	961	1,6	179,13	H083	80B	6	18000
4,8	1046	1,5	195,07	H083	80B	6	18000
4,2	1195	1,3	222,78	H083	80B	6	18000

0,75 kW

n2 [rpm]	M2 [Nm]	fs	i	Gear reducer	Size	Motor Pole	Fr2 [N]
987,4	7	3,0	1,45	HA41	80B	4	508
973,9	7	2,9	1,44	HR041	80B ⁽¹⁾	4	724
715,0	10	2,2	2,00	HR041	80B	4	794
640,0	11	1,9	1,44	HR041	80C/90S	6	819
635,2	11	1,9	1,45	HA41	80C	6	588
635,2	11	3,1	1,45	HA51	80C/90S	6	1622
550,0	13	2,1	2,55	HR041	80B	4	856
549,0	13	1,3	2,55	HA31	80B	4	611
526,8	13	2,0	2,71	HR041	80B	4	867
475,5	15	1,2	2,94	HA31	80B	4	641
475,5	15	1,4	2,94	HA41	80B	4	648
475,5	15	2,3	2,94	HA51	80B	4	1786
460,5	15	2,3	3,11	HR041	80B	4	900
460,0	15	1,4	2,00	HR041	80C/90S	6	900
440,7	16	1,1	3,18	HA31	80B	4	657
417,0	17	1,0	3,36	HA31	80B	4	670
390,2	18	2,1	3,59	HR041	80B	4	942
361,4	19	1,3	2,55	HR041	80C/90S	6	961
338,9	21	1,3	2,71	HR041	80C/90S	6	977
333,3	21	1,8	4,20	HR041	80B	4	982
312,5	22	1,5	2,94	HA51	80C/90S	6	2054
296,3	24	1,4	3,11	HR041	80C/90S	6	1000
294,7	24	1,1	4,75	HA41	80B	4	760
294,7	24	1,8	4,75	HA51	80B	4	2095
290,5	24	2,8	3,17	HR051	80C/90S	6	2500

⁽¹⁾ Available only with brake motor (TBS)

0,75 kW

n2 [rpm]	M2 [Nm]	fs	i	Gear reducer	Size	Motor	Pole	Fr2 [N]
280,0	25	1,5	5,00	HR041	80B		4	1000
272,4	26	3,3	5,25	HR051	80B		4	2500
265,8	26	2,2	5,38	HA32	80B		4	1089
262,2	27	1,6	5,45	HA51	80B		4	2178
260,0	27	1,6	5,50	HR041	80B		4	1000
256,4	27	1,4	3,59	HR041	80C/90S		6	1000
249,5	28	2,7	3,69	HR051	80C/90S		6	2500
240,6	29	2,9	5,82	HR051	80B		4	2500
234,8	30	1,5	6,09	HR041	80B		4	1000
230,0	31	2,5	4,00	HR051	80C/90S		6	2500
224,7	31	2,5	6,23	H032	80B		4	4083
219,0	32	1,2	4,20	HR041	80C/90S		6	1000
214,8	32	1,8	6,52	HA32	80B		4	1169
209,8	33	2,8	4,38	HA61	80C/90S		6	3511
195,9	35	1,9	4,70	H032	80C/90S		6	4236
195,0	36	2,4	7,33	HR051	80B		4	2500
193,7	36	1,2	4,75	HA51	80C/90S		6	2409
192,9	36	2,2	4,77	HR051	80C/90S		6	2500
188,0	37	1,0	5,00	HR041	90S		6	1000
184,5	38	2,0	7,75	HA61	80B		4	3665
182,6	38	1,1	7,67	HR041	80B		4	1000
180,4	38	2,4	7,76	H032	80B		4	4336
175,2	40	2,1	5,25	HR051	80C/90S		6	2500
172,6	40	1,4	8,11	HA32	80B		4	1257
172,6	40	2,4	8,11	HA42	80B		4	2647
171,0	41	1,4	5,38	HA32	80C		6	1261
171,0	41	2,5	5,38	HA42	80C/90S		6	2655
168,7	42	1,0	5,45	HA51	80C/90S		6	2523
167,3	42	1,0	5,50	HR041	80C/90S		6	1000
167,2	42	2,1	8,38	HR051	80B		4	2500
163,4	43	1,1	8,75	HR041	80B		4	1000
158,1	44	1,9	5,82	HR051	80C/90S		6	2500
157,9	44	2,2	8,87	H032	80B		4	4492
147,7	47	1,6	6,23	H032	80C/90S		6	4566
141,2	49	1,2	6,52	HA32	80C		6	1344
141,2	49	2,1	6,52	HA42	80C/90S		6	2830
138,0	50	2,0	10,14	H032	80B		4	4651
131,3	53	1,1	10,67	HA61	80B		4	4106
128,0	54	2,1	7,19	H042	80C/90S		6	6138
128,0	54	1,2	10,94	HA32	80B		4	1389
128,0	54	2,0	10,94	HA42	80B		4	2924
125,5	56	1,5	7,33	HR051	80C/90S		6	2500

0,75 kW

n2 [rpm]	M2 [Nm]	fs	i	Gear reducer	Motor Size	Pole	Fr2 [N]
125,5	56	2,6	7,33	HR061	80C/90S	6	3700
119,0	58	1,8	11,76	H032	80B	4	4827
118,7	59	1,3	7,75	HA61	80C/90S	6	4245
118,5	59	1,5	7,76	H032	80C/90S	6	4826
113,4	61	1,5	8,11	HA42	80C/90S	6	3044
109,9	64	1,3	8,38	HR051	80C/90S	6	2500
109,9	64	2,3	8,38	HR061	80C/90S	6	3700
105,7	65	1,6	13,25	HA42	80B	4	3117
103,8	67	1,4	8,87	H032	80C/90S	6	4983
103,2	67	2,3	8,91	H042	80C/90S	6	6515
103,2	67	2,7	13,57	H042	80B	4	6521
102,0	67	1,8	13,72	H032	80B	4	5010
96,6	71	2,8	14,50	HA52	80B ⁽¹⁾	4	4015
95,5	72	1,7	14,66	H032	80B	4	5088
90,7	77	1,3	10,14	H032	80C/90S	6	5141
89,2	78	2,2	10,31	H042	80C/90S	6	6600
87,7	78	2,3	15,96	H042	80B	4	6600
84,9	81	1,2	16,49	HA42	80B	4	3353
84,1	83	1,3	10,94	HA42	80C/90S	6	3363
83,5	82	1,7	16,77	H032	80B	4	5245
82,8	83	2,6	16,91	HA52	80B	4	4227
78,9	88	2,3	11,67	HA52	80C/90S	6	4295
78,2	89	1,2	11,76	H032	80C/90S	6	5311
78,0	89	2,0	11,80	H042	80C/90S	6	6600
76,9	89	1,6	18,20	H032	80B	4	5339
73,7	93	1,9	19,00	H042	80B	4	6600
70,4	98	1,5	19,90	H032	80B	4	5440
69,4	100	1,0	13,25	HA42	80C/90S	6	3585
69,1	100	1,1	20,26	HA42	80B	4	3591
68,4	100	2,1	20,46	HA52	80B	4	4504
67,8	102	1,8	13,57	H042	80C/90S	6	6600
67,1	104	1,2	13,72	H032	80C/90S	6	5482
66,7	103	1,8	21,00	H042	80B	4	6600
63,4	109	1,8	14,50	HA52	80C/90S	6	4618
62,8	111	1,1	14,66	H032	80C/90S	6	5500
61,7	111	1,3	22,68	H032	80B	4	5500
60,5	114	1,7	23,15	H042	80B	4	6600
58,7	117	1,2	23,83	H032	80B	4	5500
57,6	120	1,5	15,96	H042	80C/90S	6	6600
56,7	121	2,8	24,71	H052	80B	4	8000
55,4	125	2,6	16,59	H052	80C/90S	6	8000
55,1	125	1,6	25,43	HA52	80B	4	4842

⁽¹⁾ Available only with brake motor (TBS)

6.1 H/HA GEARED MOTORS (50Hz)

0,75 kW

n2 [rpm]	M2 [Nm]	fs	i	Gear reducer	Size	Motor Pole	Fr2 [N]
55,1	125	2,5	25,43	HA62	80B	4	7147
54,9	127	1,1	16,77	H032	80C/90S	6	5500
54,4	128	1,7	16,91	HA52	80C/90S	6	4861
53,8	128	1,5	26,04	H042	80B	4	6600
53,5	129	2,8	26,18	H052	80B	4	8000
53,0	130	1,1	26,39	H032	80B	4	5500
51,1	136	2,4	18,00	H052	80C/90S	6	8000
50,9	135	1,5	27,50	H042	80B	4	6600
50,5	137	1,1	18,20	H032	80C/90S	6	5500
49,2	140	2,5	28,44	H052	80B	4	8000
48,4	143	1,3	19,00	H042	80C/90S	6	6600
47,1	146	1,0	29,70	H032	80B	4	5500
46,8	147	1,5	29,89	HA52	80B	4	5110
46,8	147	2,2	29,89	HA62	80B	4	7543
46,1	151	2,2	19,97	H052	80C/90S	6	8000
46,0	150	1,6	30,45	H042	80B	4	6600
45,0	154	1,3	20,46	HA52	80C/90S	6	5180
45,0	154	2,1	20,46	HA62	80C/90S	6	7646
44,4	155	2,7	31,52	H052	80B	4	8000
43,8	159	1,1	21,00	H042	80C/90S	6	6600
42,6	162	1,1	32,89	H032	80B	4	5500
42,5	164	2,1	21,67	H052	80C/90S	6	8000
42,4	162	2,6	33,00	H052	80B	4	8000
41,1	167	1,4	34,10	H042	80B	4	6600
39,7	175	1,1	23,15	H042	80C/90S	6	6600
38,7	178	1,4	36,17	HA52	80B	4	5445
38,7	178	2,3	36,17	HA62	80B	4	8000
37,2	186	1,8	24,71	H052	80C/90S	6	8000
37,1	185	1,3	37,76	H042	80B	4	6600
36,2	192	1,1	25,43	HA52	80C/90S	6	5570
36,2	192	1,6	25,43	HA62	80C/90S	6	8000
35,9	191	2,2	38,98	H052	80B	4	8000
35,1	198	1,8	26,18	H052	80C/90S	6	8000
32,4	215	1,6	28,44	H052	80C/90S	6	8000
32,0	215	1,1	43,75	H042	80B	4	6600
31,4	221	2,6	29,33	H062	80C/90S	6	12000
31,1	221	1,1	44,95	HA52	80B	4	5855
31,1	221	1,7	44,95	HA62	80B	4	8000
30,9	223	1,9	45,36	H052	80B	4	8000
30,8	226	1,4	29,89	HA62	80C/90S	6	8000
30,4	226	3,2	46,06	H062	80B	4	12000
30,2	230	1,0	30,45	H042	80C/90S	6	6600

6.1 H/HA GEARED MOTORS (50Hz)

0,75 kW

n2 [rpm]	M2 [Nm]	fs	i	Gear reducer	Size	Motor Pole	Fr2 [N]
29,5	233	1,0	47,53	H042	80B	4	6600
29,2	238	1,8	31,52	H052	80C/90S	6	8000
28,8	242	3,0	32,00	H062	80C/90S	6	12000
28,5	241	1,7	49,13	H052	80B	4	8000
28,1	244	1,0	49,78	HA52	80B	4	6000
28,1	239	1,1	49,80	HA53	80B	4	6000
28,1	244	1,3	49,78	HA62	80B	4	8000
28,1	239	1,7	49,80	HA63	80B	4	8000
27,9	249	1,7	33,00	H052	80C/90S	6	8000
25,4	273	1,5	36,17	HA62	80C/90S	6	8000
24,9	276	1,5	56,11	H052	80B	4	8000
24,9	279	2,4	36,99	H062	80C/90S	6	12000
23,8	283	1,5	58,81	H053	80B	4	8000
23,6	294	1,4	38,98	H052	80C/90S	6	8000
23,2	290	1,4	60,25	HA63	80B	4	8000
22,8	304	2,4	40,33	H062	80C/90S	6	12000
22,6	304	1,2	61,87	HA62	80B	4	8000
20,5	339	1,1	44,95	HA62	80C/90S	6	8000
20,3	342	1,2	45,36	H052	80C/90S	6	8000
20,0	348	2,1	46,06	H062	80C/90S	6	12000
19,2	350	1,2	72,75	H053	80B	4	8000
18,7	371	1,1	49,13	H052	80C/90S	6	8000
18,7	360	1,1	74,88	HA63	80B	4	8000
18,6	366	2,0	49,45	H063	90S	6	12000
18,5	368	1,1	49,80	HA63	80C/90S	6	8000
16,8	415	1,0	56,11	H052	90S	6	8000
16,8	404	1,8	54,61	H063	90S	6	12000
16,3	413	1,7	85,82	H063	80B	4	12000
16,0	425	1,0	58,81	H053	90S	6	8000
15,9	423	1,0	90,51	H053	80B	4	8000
14,8	456	1,6	94,76	H063	80B	4	12000
14,3	472	3,3	98,09	H083	80B	4	18000
13,5	503	1,4	68,00	H063	90S	6	12000
12,9	528	2,9	71,48	H083	80C/90S	6	18000
12,4	542	2,8	112,78	H083	80B	4	18000
11,9	567	1,3	118,00	H063	80B	4	12000
11,7	583	2,6	78,87	H083	80C/90S	6	18000
11,3	598	2,6	124,44	H083	80B	4	18000
10,8	632	2,4	85,56	H083	80C/90S	6	18000
10,7	634	1,1	85,82	H063	80C/90S	6	12000
10,3	651	1,1	135,40	H063	80B	4	12000
9,8	684	2,2	142,15	H083	80B	4	18000

0,75 kW

n2 [rpm]	M2 [Nm]	fs	i	Gear reducer	Size	Motor Pole	Fr2 [N]
9,7	700	1,0	94,76	H063	80C/90S	6	12000
9,4	719	1,0	149,51	H063	80B	4	12000
9,4	725	2,1	98,09	H083	80C/90S	6	18000
9,0	744	2,1	154,76	H083	80B	4	18000
8,6	781	2,0	162,35	H083	80B	4	18000
8,2	834	1,8	112,78	H083	80C/90S	6	18000
7,8	861	1,8	179,13	H083	80B	4	18000
7,4	920	1,7	124,44	H083	80C/90S	6	18000
7,2	938	1,6	195,07	H083	80B	4	18000
6,5	1051	1,5	142,15	H083	80C/90S	6	18000
6,4	1060	2,8	143,42	H103	90S	6	22000
6,3	1071	1,4	222,78	H083	80B	4	18000
5,9	1144	1,3	154,76	H083	80C/90S	6	18000
5,7	1200	1,3	162,35	H083	80C/90S	6	18000
5,7	1189	2,5	160,82	H103	90S	6	22000
5,1	1324	1,2	179,13	H083	80C/90S	6	18000
5,1	1338	2,2	181,07	H103	90S	6	22000
4,7	1442	1,1	195,07	H083	80C/90S	6	18000
4,7	1435	2,1	194,21	H103	90S	6	22000
4,3	1593	1,9	215,45	H103	90S	6	22000
3,8	1793	1,5	242,59	H103	90S	6	22000

0,92 kW

n2 [rpm]	M2 [Nm]	fs	i	Gear reducer	Size	Motor Pole	Fr2 [N]
973,9	9	2,4	1,44	HR041	80C ⁽¹⁾	4	717
966,7	9	2,4	1,45	HA41	80C ⁽¹⁾	4	512
700,0	12	1,7	2,00	HR041	80C ⁽¹⁾	4	788
550,0	15	1,7	2,55	HR041	80C ⁽¹⁾	4	843
549,0	16	1,0	2,55	HA31	80C ⁽¹⁾	4	611
515,8	17	1,6	2,71	HR041	80C ⁽¹⁾	4	858
475,5	18	1,2	2,94	HA41	80C ⁽¹⁾	4	648
475,5	18	1,9	2,94	HA51	80C ⁽¹⁾	4	1786
450,8	19	1,8	3,11	HR041	80C ⁽¹⁾	4	889
390,2	22	1,7	3,59	HR041	80C ⁽¹⁾	4	923
350,0	24	3,2	4,00	HR051	80C ⁽¹⁾	4	2500
333,3	26	1,5	4,20	HR041	80C ⁽¹⁾	4	960
298,1	28	2,4	4,70	H032	80C ⁽¹⁾	4	3715
294,7	29	1,5	4,75	HA51	80C ⁽¹⁾	4	2095
293,5	29	2,8	4,77	HR051	80C ⁽¹⁾	4	2500
280,0	30	1,2	5,00	HR041	80C ⁽¹⁾	4	1000
266,7	32	2,7	5,25	HR051	80C ⁽¹⁾	4	2500

⁽¹⁾ Available only with brake motor (TBS)

6.1 H/HA GEARED MOTORS (50Hz)

0,92 kW

n2 [rpm]	M2 [Nm]	fs	i	Gear reducer	Size	Motor Pole	Fr2 [N]
260,3	32	1,8	5,38	HA32	80C ⁽¹⁾	4	1096
256,7	33	1,3	5,45	HA51	80C ⁽¹⁾	4	2194
254,5	33	1,3	5,50	HR041	80C ⁽¹⁾	4	1000
240,6	35	2,4	5,82	HR051	80C ⁽¹⁾	4	2500
229,9	37	1,2	6,09	HR041	80C ⁽¹⁾	4	1000
224,7	38	2,0	6,23	H032	80C ⁽¹⁾	4	4010
214,8	39	1,5	6,52	HA32	80C ⁽¹⁾	4	1169
214,8	39	2,6	6,52	HA42	80C ⁽¹⁾	4	2461
194,8	43	2,7	7,19	H042	80C ⁽¹⁾	4	5376
190,9	45	1,9	7,33	HR051	80C ⁽¹⁾	4	2500
190,9	45	3,2	7,33	HR061	80C ⁽¹⁾	4	3700
180,6	47	1,6	7,75	HA61	80C ⁽¹⁾	4	3691
180,4	47	1,9	7,76	H032	80C ⁽¹⁾	4	4246
172,6	49	1,1	8,11	HA32	80C ⁽¹⁾	4	1257
172,6	49	1,9	8,11	HA42	80C ⁽¹⁾	4	2647
167,2	51	1,7	8,38	HR051	80C ⁽¹⁾	4	2500
167,2	51	2,8	8,38	HR061	80C ⁽¹⁾	4	3700
157,9	53	1,8	8,87	H032	80C ⁽¹⁾	4	4389
157,1	54	2,8	8,91	H042	80C ⁽¹⁾	4	5712
138,0	61	1,7	10,14	H032	80C ⁽¹⁾	4	4533
135,7	62	2,8	10,31	H042	80C ⁽¹⁾	4	5946
128,0	66	1,6	10,94	HA42	80C ⁽¹⁾	4	2924
120,0	70	2,9	11,67	HA52	80C ⁽¹⁾	4	3735
119,0	71	1,5	11,76	H032	80C ⁽¹⁾	4	4691
118,6	71	2,5	11,80	H042	80C ⁽¹⁾	4	6165
105,7	80	1,3	13,25	HA42	80C ⁽¹⁾	4	3117
103,2	82	2,2	13,57	H042	80C ⁽¹⁾	4	6396
102,0	83	1,5	13,72	H032	80C ⁽¹⁾	4	4851
96,6	87	2,3	14,50	HA52	80C ⁽¹⁾	4	4015
95,5	88	1,4	14,66	H032	80C ⁽¹⁾	4	4918
87,7	96	1,9	15,96	H042	80C ⁽¹⁾	4	6600
84,9	99	1,0	16,49	HA42	80C ⁽¹⁾	4	3353
83,5	101	1,4	16,77	H032	80C ⁽¹⁾	4	5051
82,8	102	2,1	16,91	HA52	80C ⁽¹⁾	4	4227
76,9	110	1,3	18,20	H032	80C ⁽¹⁾	4	5129
73,7	114	1,6	19,00	H042	80C ⁽¹⁾	4	6600
70,4	120	1,2	19,90	H032	80C ⁽¹⁾	4	5209
70,1	120	2,8	19,97	H052	80C ⁽¹⁾	4	8000
68,4	123	1,7	20,46	HA52	80C ⁽¹⁾	4	4504
68,4	123	2,7	20,46	HA62	80C ⁽¹⁾	4	6647
66,7	127	1,4	21,00	H042	80C ⁽¹⁾	4	6600
64,6	131	2,6	21,67	H052	80C ⁽¹⁾	4	8000

⁽¹⁾ Available only with brake motor (TBS)

0,92 kW

n2 [rpm]	M2 [Nm]	fs	i	Gear reducer	Size	Motor Pole	Fr2 [N]
61,7	137	1,1	22,68	H032	80C ⁽¹⁾	4	5320
60,5	139	1,3	23,15	H042	80C ⁽¹⁾	4	6600
58,7	144	1,0	23,83	H032	80C ⁽¹⁾	4	5359
56,7	149	2,3	24,71	H052	80C ⁽¹⁾	4	8000
55,1	153	1,3	25,43	HA52	80C ⁽¹⁾	4	4842
55,1	153	2,0	25,43	HA62	80C ⁽¹⁾	4	7147
53,8	157	1,2	26,04	H042	80C ⁽¹⁾	4	6600
53,5	158	2,2	26,18	H052	80C ⁽¹⁾	4	8000
50,9	166	1,2	27,50	H042	80C ⁽¹⁾	4	6600
49,2	171	2,1	28,44	H052	80C ⁽¹⁾	4	8000
46,8	180	1,2	29,89	HA52	80C ⁽¹⁾	4	5110
46,8	180	1,8	29,89	HA62	80C ⁽¹⁾	4	7543
46,0	183	1,3	30,45	H042	80C ⁽¹⁾	4	6600
44,4	190	2,2	31,52	H052	80C ⁽¹⁾	4	8000
42,4	199	2,1	33,00	H052	80C ⁽¹⁾	4	8000
41,1	205	1,2	34,10	H042	80C ⁽¹⁾	4	6600
38,7	218	1,2	36,17	HA52	80C ⁽¹⁾	4	5445
38,7	218	1,8	36,17	HA62	80C ⁽¹⁾	4	8000
37,8	223	3,1	36,99	H062	80C ⁽¹⁾	4	12000
37,1	228	1,0	37,76	H042	80C ⁽¹⁾	4	6600
35,9	235	1,8	38,98	H052	80C ⁽¹⁾	4	8000
34,7	243	3,0	40,33	H062	80C ⁽¹⁾	4	12000
31,1	271	1,4	44,95	HA62	80C ⁽¹⁾	4	8000
30,9	273	1,5	45,36	H052	80C ⁽¹⁾	4	8000
30,4	278	2,6	46,06	H062	80C ⁽¹⁾	4	12000
28,5	296	1,4	49,13	H052	80C ⁽¹⁾	4	8000
28,1	300	1,1	49,78	HA62	80C ⁽¹⁾	4	8000
28,1	294	1,4	49,80	HA63	80C ⁽¹⁾	4	8000
24,9	338	1,2	56,11	H052	80C ⁽¹⁾	4	8000
23,8	347	1,2	58,81	H053	80C ⁽¹⁾	4	8000
23,2	355	1,1	60,25	HA63	80C ⁽¹⁾	4	8000
22,6	373	1,0	61,87	HA62	80C ⁽¹⁾	4	8000
17,8	465	3,3	78,87	H083	80C ⁽¹⁾	4	18000
16,4	505	3,0	85,56	H083	80C ⁽¹⁾	4	18000
16,3	506	1,4	85,82	H063	80C ⁽¹⁾	4	12000
14,8	559	1,3	94,76	H063	80C ⁽¹⁾	4	12000
14,3	579	2,7	98,09	H083	80C ⁽¹⁾	4	18000
12,4	665	2,3	112,78	H083	80C ⁽¹⁾	4	18000
11,9	696	1,0	118,00	H063	80C ⁽¹⁾	4	12000
11,3	734	2,1	124,44	H083	80C ⁽¹⁾	4	18000
9,8	839	1,8	142,15	H083	80C ⁽¹⁾	4	18000
9,0	913	1,7	154,76	H083	80C ⁽¹⁾	4	18000

⁽¹⁾ Available only with brake motor (TBS)

0,92 kW

n2 [rpm]	M2 [Nm]	fs	i	Gear reducer	Motor Size	Pole	Fr2 [N]
8,6	958	1,6	162,35	H083	80C ⁽¹⁾	4	18000
7,8	1057	1,5	179,13	H083	80C ⁽¹⁾	4	18000
7,2	1151	1,3	195,07	H083	80C ⁽¹⁾	4	18000
6,3	1314	1,2	222,78	H083	80C ⁽¹⁾	4	18000

1,10 kW

n2 [rpm]	M2 [Nm]	fs	i	Gear reducer	Motor Size	Pole	Fr2 [N]
980,9	10	2,0	1,44	HR041	80D/90S	4	708
973,6	10	2,0	1,45	HA41	80D ⁽¹⁾	4	510
966,7	11	3,2	1,45	HA51	80D/90S	4	1410
738,6	14	2,4	1,27	HR051	90L/100LR	6	2028
700,0	15	1,4	2,00	HR041	80D/90S	4	777
653,9	16	1,3	1,44	HR041	90L	6	791
649,0	16	2,1	1,45	HA51	90L	6	1610
550,0	19	1,4	2,55	HR041	80D/90S	4	829
519,5	20	1,3	2,71	HR041	80D/90S	4	841
478,9	21	1,6	2,94	HA51	80D/90S	4	1782
450,8	23	1,5	3,11	HR041	80D/90S	4	872
445,3	23	3,0	3,17	HR051	80D/90S	4	2357
437,6	24	2,2	2,13	HR051	90L/100LR	6	2368
393,0	26	1,5	3,59	HR041	80D/90S	4	902
382,4	27	2,9	3,69	HR051	80D/90S	4	2463
372,0	28	2,8	2,50	HA61	90L/100LR	6	2901
365,6	28	2,1	2,57	HR051	90L/100LR	6	2493
352,5	29	2,7	4,00	HR051	80D/90S	4	2500
333,3	31	1,2	4,20	HR041	80D/90S	4	937
321,6	32	3,0	4,38	HA61	80D/90S	4	3045
315,8	33	1,0	2,94	HA51	90L	6	2047
302,7	34	1,0	3,11	HR041	90L	6	956
300,3	34	2,1	4,70	H032	80D/90S	4	3650
296,8	35	2,0	3,17	HR051	90L/100LR	6	2500
294,7	35	1,2	4,75	HA51	80D/90S	4	2095
293,5	35	2,3	4,77	HR051	80D/90S	4	2500
282,0	36	1,1	5,00	HR041	80D/90S	4	973
268,6	38	2,2	5,25	HR051	80D/90S	4	2500
262,1	38	1,5	5,38	HA32	80D ⁽¹⁾	4	1094
260,3	39	2,6	5,38	HA42	80D/90S	4	2308
256,7	40	1,1	5,45	HA51	80D/90S	4	2194
256,4	40	1,1	5,50	HR041	80D/90S	4	992
252,2	41	1,9	3,69	HR051	90L/100LR	6	2500
252,2	41	3,1	3,69	HR061	90L/100LR	6	3700

⁽¹⁾ Available only with brake motor (TBS)

1,10 kW

n2 [rpm]	M2 [Nm]	fs	i	Gear reducer	Motor Size	Pole	Fr2 [N]
242,3	42	2,0	5,82	HR051	80D/90S	4	2500
235,0	44	1,8	4,00	HR051	90L/100LR	6	2500
235,0	44	2,9	4,00	HR061	90L/100LR	6	3700
226,4	45	1,7	6,23	H032	80D/90S	4	3927
216,3	47	1,2	6,52	HA32	80D ⁽¹⁾	4	1166
216,3	47	2,2	6,52	HA42	80D/90S	4	2455
212,1	49	1,9	4,38	HA61	90L/100LR	6	3499
200,2	51	1,4	4,70	H032	90L/100LR	6	4043
195,0	53	1,5	4,77	HR051	90L/100LR	6	2500
195,0	53	2,6	4,77	HR061	90L/100LR	6	3700
194,8	52	2,2	7,19	H042	80D/90S	4	5306
192,3	53	1,6	7,33	HR051	80D/90S	4	2500
192,3	53	2,7	7,33	HR061	80D/90S	4	3700
181,9	56	1,4	7,75	HA61	80D/90S	4	3682
181,6	56	1,6	7,76	H032	80D/90S	4	4144
177,1	58	1,5	5,25	HR051	90L/100LR	6	2500
177,1	58	2,5	5,25	HR061	90L/100LR	6	3700
173,9	58	1,6	8,11	HA42	80D/90S	4	2640
172,9	59	1,7	5,38	HA42	90L	6	2645
170,3	60	1,9	5,46	H042	90L/100LR	6	5500
168,4	61	1,4	8,38	HR051	80D/90S	4	2500
168,4	61	2,4	8,38	HR061	80D/90S	4	3700
161,6	64	1,3	5,82	HR051	90L/100LR	6	2500
161,6	64	2,3	5,82	HR061	90L/100LR	6	3700
158,2	64	2,4	8,91	H042	80D/90S	4	5614
157,9	64	1,5	8,87	H032	80D/90S	4	4280
149,5	68	2,5	6,22	HA52	90L/100LR	6	3471
149,3	68	1,1	6,23	H032	90L/100LR	6	4327
144,2	71	1,4	6,52	HA42	90L	6	2810
139,0	73	1,4	10,14	H032	80D/90S	4	4402
136,7	74	2,3	10,31	H042	80D/90S	4	5835
129,4	79	1,5	7,19	H042	90L/100LR	6	5912
128,0	79	1,4	10,94	HA42	80D/90S	4	2924
126,8	81	1,0	7,33	HR051	90L	6	2500
126,8	81	1,8	7,33	HR061	90L/100LR	6	3700
120,3	85	2,0	7,73	HA52	90L/100LR	6	3732
120,0	84	2,4	11,67	HA52	80D/90S	4	3735
119,8	85	1,1	7,76	H032	90L/100LR	6	4532
119,0	85	1,2	11,76	H032	80D/90S	4	4547
118,6	85	2,1	11,80	H042	80D/90S	4	6050
114,7	89	1,1	8,11	HA42	90L	6	3033
111,0	93	1,6	8,38	HR061	90L/100LR	6	3700

⁽¹⁾ Available only with brake motor (TBS)

1,10 kW

n2 [rpm]	M2 [Nm]	fs	i	Gear reducer	Motor Size	Pole	Fr2 [N]
110,1	93	3,2	8,44	HR081	90L	6	4000
109,1	93	2,6	8,53	H052	90L/100LR	6	7965
106,4	95	1,1	13,25	HA42	80D/90S	4	3110
104,3	98	1,6	8,91	H042	90L/100LR	6	6238
103,2	98	1,9	13,57	H042	80D/90S	4	6263
102,0	99	1,2	13,72	H032	80D/90S	4	4683
97,3	105	2,5	9,56	H052	90L/100LR	6	8000
97,2	104	1,9	14,50	HA52	80D/90S	4	4006
96,4	106	2,0	9,64	HA52	90L/100LR	6	4017
95,5	106	1,2	14,66	H032	80D/90S	4	4739
90,2	113	1,5	10,31	H042	90L/100LR	6	6458
87,7	115	1,6	15,96	H042	80D/90S	4	6509
84,4	120	2,7	16,59	H052	80D/90S	4	8000
83,5	121	1,1	16,77	H032	80D/90S	4	4845
82,8	122	1,8	16,91	HA52	80D/90S	4	4227
80,8	126	2,2	11,51	H052	90L/100LR	6	8000
79,7	128	1,6	11,67	HA52	90L/100LR	6	4280
79,7	128	2,5	11,67	HA62	90L/100LR	6	6317
78,8	129	1,4	11,80	H042	90L/100LR	6	6600
77,8	130	2,6	18,00	H052	80D/90S	4	8000
76,9	131	1,1	18,20	H032	80D/90S	4	4905
73,7	137	1,3	19,00	H042	80D/90S	4	6600
70,4	143	1,0	19,90	H032	80D/90S	4	4965
70,1	144	2,3	19,97	H052	80D/90S	4	8000
68,5	149	1,2	13,57	H042	90L/100LR	6	6600
68,4	147	1,4	20,46	HA52	80D/90S	4	4504
68,4	147	2,3	20,46	HA62	80D/90S	4	6647
66,7	151	1,2	21,00	H042	80D/90S	4	6600
65,3	156	2,0	14,24	H052	90L/100LR	6	8000
64,6	156	2,2	21,67	H052	80D/90S	4	8000
64,1	159	1,3	14,50	HA52	90L/100LR	6	4602
64,1	159	1,9	14,50	HA62	90L/100LR	6	6792
60,5	167	1,1	23,15	H042	80D/90S	4	6600
58,3	175	1,0	15,96	H042	90L/100LR	6	6600
56,7	178	1,9	24,71	H052	80D/90S	4	8000
56,0	182	1,8	16,59	H052	90L/100LR	6	8000
55,1	183	1,1	25,43	HA52	80D/90S	4	4842
55,1	183	1,7	25,43	HA62	80D/90S	4	7147
55,0	185	1,2	16,91	HA52	90L/100LR	6	4844
55,0	185	1,9	16,91	HA62	90L/100LR	6	7150
53,8	188	1,0	26,04	H042	80D/90S	4	6600
53,5	189	1,9	26,18	H052	80D/90S	4	8000

1,10 kW

n2 [rpm]	M2 [Nm]	fs	i	Gear reducer	Motor Size	Pole	Fr2 [N]
51,7	197	1,7	18,00	H052	90L/100LR	6	8000
50,9	198	1,0	27,50	H042	80D/90S	4	6600
49,2	205	1,7	28,44	H052	80D/90S	4	8000
47,7	211	2,7	29,33	H062	80D/90S	4	12000
46,8	215	1,0	29,89	HA52	80D/90S	4	5110
46,8	215	1,5	29,89	HA62	80D/90S	4	7543
46,6	219	1,5	19,97	H052	90L/100LR	6	8000
46,0	219	1,1	30,45	H042	80D/90S	4	6600
45,5	224	1,5	20,46	HA62	90L/100LR	6	7618
44,4	227	1,8	31,52	H052	80D/90S	4	8000
43,8	231	3,1	32,00	H062	80D/90S	4	12000
42,9	237	1,4	21,67	H052	90L/100LR	6	8000
42,4	238	1,8	33,00	H052	80D/90S	4	8000
40,0	255	2,4	23,27	H062	90L/100LR	6	12000
39,5	255	1,0	36,17	HA52	90S	4	5407
38,7	261	1,5	36,17	HA62	80D/90S	4	8000
37,8	266	2,6	36,99	H062	80D/90S	4	12000
37,6	271	1,2	24,71	H052	90L/100LR	6	8000
36,6	279	1,1	25,43	HA62	90L/100LR	6	8000
36,2	281	2,2	25,70	H062	90L/100LR	6	12000
35,9	281	1,5	38,98	H052	80D/90S	4	8000
35,5	287	1,2	26,18	H052	90L/100LR	6	8000
34,7	291	2,5	40,33	H062	80D/90S	4	12000
32,7	311	1,1	28,44	H052	90L/100LR	6	8000
31,7	321	1,8	29,33	H062	90L/100LR	6	12000
31,4	324	1,0	29,89	HA62	90L	6	8000
31,1	324	1,2	44,95	HA62	80D/90S	4	8000
30,9	327	1,3	45,36	H052	80D/90S	4	8000
30,4	332	2,2	46,06	H062	80D/90S	4	12000
29,5	345	1,2	31,52	H052	90L/100LR	6	8000
29,1	350	2,1	32,00	H062	90L/100LR	6	12000
28,5	354	1,2	49,13	H052	80D/90S	4	8000
28,3	349	2,1	49,45	H063	90S	4	12000
28,2	361	1,2	33,00	H052	90L	6	8000
28,1	351	1,2	49,80	HA63	80D/90S	4	8000
25,7	396	1,0	36,17	HA62	90L	6	8000
25,6	385	1,9	54,61	H063	90S	4	12000
25,1	405	1,7	36,99	H062	90L/100LR	6	12000
24,9	404	1,0	56,11	H052	80D/90S	4	8000
24,4	418	1,0	38,98	H052	100LR	6	8000
24,0	424	3,2	38,70	H082	90L	6	18000
23,8	415	1,0	58,81	H053	80D/90S	4	8000

6.1 H/HA GEARED MOTORS (50Hz)

1,10 kW

n2 [rpm]	M2 [Nm]	fs	i	Gear reducer	Motor Size	Pole	Fr2 [N]
23,1	442	1,6	40,33	H062	90L/100LR	6	12000
21,8	468	2,9	42,75	H082	90L/100LR	6	18000
20,6	480	1,5	68,00	H063	90S	4	12000
20,2	504	1,4	46,06	H062	90L/100LR	6	12000
19,6	504	3,0	71,48	H083	80D/90S	4	18000
19,3	527	2,6	48,13	H082	90L/100LR	6	18000
18,8	530	1,4	49,45	H063	90L/100LR	6	12000
17,8	556	2,8	78,87	H083	80D/90S	4	18000
17,0	586	1,2	54,61	H063	90L/100LR	6	12000
16,5	606	2,3	56,53	H083	90L/100LR	6	18000
16,4	603	2,5	85,56	H083	80D/90S	4	18000
16,3	605	1,2	85,82	H063	80D/90S	4	12000
14,8	668	1,1	94,76	H063	80D/90S	4	12000
14,3	692	2,2	98,09	H083	80D/90S	4	18000
13,8	721	1,0	68,00	H063	90L/100LR	6	12000
13,0	767	2,0	71,48	H083	90L/100LR	6	18000
12,4	796	1,9	112,78	H083	80D/90S	4	18000
11,8	846	1,8	78,87	H083	90L/100LR	6	18000
11,3	878	1,8	124,44	H083	80D/90S	4	18000
10,9	918	1,7	85,56	H083	90L/100LR	6	18000
10,2	980	3,1	93,36	H103	100LR	6	22000
9,8	1003	1,5	142,15	H083	80D/90S	4	18000
9,8	1012	3,0	143,42	H103	90S	4	22000
9,5	1052	1,5	98,09	H083	90L/100LR	6	18000
9,5	1051	2,8	100,07	H103	100LR	6	22000
9,0	1092	1,4	154,76	H083	80D/90S	4	18000
8,7	1134	2,6	160,82	H103	90S	4	22000
8,6	1145	1,3	162,35	H083	80D/90S	4	18000
8,2	1210	1,3	112,78	H083	90L/100LR	6	18000
7,9	1269	2,4	120,84	H103	100LR	6	22000
7,8	1263	1,2	179,13	H083	80D/90S	4	18000
7,7	1277	2,3	181,07	H103	90S	4	22000
7,5	1335	1,2	124,44	H083	90L/100LR	6	18000
7,4	1346	3,2	128,18	H123	100LR	6	30000
7,2	1376	1,1	195,07	H083	80D/90S	4	18000
7,2	1370	2,2	194,21	H103	90S	4	22000
7,1	1407	2,1	134,06	H103	100LR	6	22000
6,6	1520	2,8	144,79	H123	100LR	6	30000
6,5	1524	1,0	142,15	H083	90L/100LR	6	18000
6,5	1538	1,9	143,42	H103	90L/100LR	6	22000
6,5	1520	2,0	215,45	H103	90S	4	22000
6,1	1630	2,6	155,22	H123	100LR	6	30000

6.1 H/HA GEARED MOTORS (50Hz)

1,10 kW

n2 [rpm]	M2 [Nm]	fs	i	Gear reducer	Motor Size	Pole	Fr2 [N]
5,8	1725	1,7	160,82	H103	90L/100LR	6	22000
5,8	1711	1,5	242,59	H103	90S	4	22000
5,5	1814	2,4	172,80	H123	100LR	6	30000
5,1	1942	1,5	181,07	H103	90L/100LR	6	22000
5,0	1986	2,1	189,19	H123	100LR	6	30000
4,8	2083	1,4	194,21	H103	90L/100LR	6	22000
4,6	2178	2,0	207,43	H123	100LR	6	30000
4,3	2311	1,3	215,45	H103	90L/100LR	6	22000
4,1	2424	1,8	230,92	H123	100LR	6	30000
3,8	2602	1,0	242,59	H103	90L/100LR	6	22000
3,7	2726	1,6	259,64	H123	100LR	6	30000

1,50 kW

n2 [rpm]	M2 [Nm]	fs	i	Gear reducer	Motor Size	Pole	Fr2 [N]
1100,0	13	2,7	1,27	HR051	90L/90LA	4	1775
987,8	14	1,5	1,44	HR041	90L/90LA	4	689
980,5	14	2,4	1,45	HA51	90L/90LA	4	1403
738,6	19	1,8	1,27	HR051	100L/100LA	6	1997
710,0	20	1,1	2,00	HR041	90L/90LA	4	750
668,2	21	2,5	2,13	HR051	90L/90LA	4	2057
662,3	21	2,4	1,42	HR051	100L/100LA	6	2061
560,0	25	3,1	2,50	HA61	90L/90LA	4	2531
557,9	25	1,0	2,55	HR041	90L/90LA	4	795
544,4	26	2,4	2,57	HR051	90L/90LA	4	2181
482,3	29	1,2	2,94	HA51	90L/90LA	4	1778
450,8	31	1,1	3,11	HR041	90L/90LA	4	834
448,4	31	2,2	3,17	HR051	90L/90LA	4	2303
442,4	32	1,6	2,13	HR051	100L/100LA	6	2309
390,2	36	1,1	3,59	HR041	90L/90LA	4	859
379,7	37	2,1	3,69	HR051	90L/90LA	4	2409
372,0	38	2,0	2,50	HA61	100L/100LA	6	2901
361,7	39	1,5	2,57	HR051	100L/100LA	6	2439
361,7	39	2,6	2,57	HR061	100L/100LA	6	3659
350,0	40	1,9	4,00	HR051	90L/90LA	4	2462
350,0	40	3,2	4,00	HR061	90L/90LA	4	3696
319,3	44	2,2	4,38	HA61	90L/90LA	4	3053
298,1	46	1,5	4,70	H032	90L/90LA	4	3529
297,7	47	1,7	4,77	HR051	90L/90LA	4	2500
297,7	47	2,9	4,77	HR061	90L/90LA	4	3700
293,7	48	1,4	3,17	HR051	100L/100LA	6	2500
293,7	48	2,3	3,17	HR061	100L/100LA	6	3700

1,50 kW

n2 [rpm]	M2 [Nm]	fs	i	Gear reducer	Motor Size	Pole	Fr2 [N]
266,7	52	1,6	5,25	HR051	90L/90LA	4	2500
266,7	52	2,8	5,25	HR061	90L/90LA	4	3700
260,3	53	1,9	5,38	HA42	90L/90LA	4	2308
256,3	54	2,2	5,46	H042	90L/90LA	4	4794
252,2	56	1,4	3,69	HR051	100L/100LA	6	2500
252,2	56	2,3	3,69	HR061	100L/100LA	6	3700
240,6	58	1,5	5,82	HR051	90L/90LA	4	2500
240,6	58	2,5	5,82	HR061	90L/90LA	4	3700
235,0	60	1,3	4,00	HR051	100L/100LA	6	2500
235,0	60	2,1	4,00	HR061	100L/100LA	6	3700
225,0	61	2,8	6,22	HA52	90L/90LA	4	3029
224,7	61	1,2	6,23	H032	90L/90LA	4	3764
214,8	64	1,6	6,52	HA42	90L/90LA	4	2461
212,1	66	1,4	4,38	HA61	100L/100LA	6	3499
195,0	72	1,1	4,77	HR051	100L/100LA	6	2500
195,0	72	1,9	4,77	HR061	100L/100LA	6	3700
194,8	71	1,6	7,19	H042	90L/90LA	4	5150
190,9	73	1,2	7,33	HR051	90L/90LA	4	2500
190,9	73	2,0	7,33	HR061	90L/90LA	4	3700
181,0	76	2,3	7,73	HA52	90L/90LA	4	3256
180,8	77	2,3	5,14	HA52	100L/100LA	6	3257
180,6	77	1,0	7,75	HA61	90L/90LA	4	3691
180,4	76	1,2	7,76	H032	90L/90LA	4	3939
177,1	79	1,1	5,25	HR051	100L/100LA	6	2500
177,1	79	1,8	5,25	HR061	100L/100LA	6	3700
172,6	80	1,2	8,11	HA42	90L/90LA	4	2647
170,3	82	1,4	5,46	H042	100L/100LA	6	5319
167,2	83	1,0	8,38	HR051	90L/90LA	4	2500
167,2	83	1,7	8,38	HR061	90L/90LA	4	3700
162,4	86	2,2	5,73	H052	100L/100LA	6	6961
159,8	88	1,7	5,82	HR061	100L/100LA	6	3700
157,9	87	1,1	8,87	H032	90L/90LA	4	4039
157,1	88	1,7	8,91	H042	90L/90LA	4	5431
152,9	92	3,2	6,08	HR081	100L/100LA	6	4000
149,5	93	1,9	6,22	HA52	100L/100LA	6	3471
146,4	94	2,8	9,56	H052	90L/90LA	4	7166
145,2	95	2,3	9,64	HA52	90L/90LA	4	3505
138,0	100	1,0	10,14	H032	90L/90LA	4	4133
135,7	101	1,7	10,31	H042	90L/90LA	4	5621
134,9	103	2,0	6,89	H052	100L/100LA	6	7319
129,4	107	1,1	7,19	H042	100L/100LA	6	5674
128,0	107	1,0	10,94	HA42	90L/90LA	4	2924

1,50 kW

n2 [rpm]	M2 [Nm]	fs	i	Gear reducer	Motor Size	Pole	Fr2 [N]
126,8	111	1,3	7,33	HR061	100L/100LA	6	3700
124,0	113	2,6	7,50	HR081	100L/100LA	6	4000
121,6	113	2,5	11,51	H052	90L/90LA	4	7530
120,3	115	1,5	7,73	HA52	100L/100LA	6	3732
120,3	115	2,4	7,73	HA62	100L/100LA	6	5508
120,0	115	1,8	11,67	HA52	90L/90LA	4	3735
120,0	115	2,8	11,67	HA62	90L/90LA	4	5512
118,6	116	1,6	11,80	H042	90L/90LA	4	5794
111,0	126	1,1	8,38	HR061	100L/100LA	6	3700
110,1	127	2,3	8,44	HR081	100L/100LA	6	4000
109,1	127	1,9	8,53	H052	100L/100LA	6	7738
104,3	133	1,1	8,91	H042	100L/100LA	6	5943
103,2	133	1,4	13,57	H042	90L/90LA	4	5968
98,3	140	2,2	14,24	H052	90L/90LA	4	7954
97,3	143	1,9	9,56	H052	100L/100LA	6	7966
96,6	142	1,4	14,50	HA52	90L/90LA	4	4015
96,6	142	2,1	14,50	HA62	90L/90LA	4	5926
96,4	144	1,5	9,64	HA52	100L/100LA	6	4017
96,4	144	2,3	9,64	HA62	100L/100LA	6	5929
90,2	154	1,1	10,31	H042	100L/100LA	6	6118
87,7	157	1,2	15,96	H042	90L/90LA	4	6163
84,4	163	2,0	16,59	H052	90L/90LA	4	8000
82,8	166	1,3	16,91	HA52	90L/90LA	4	4227
82,8	166	2,2	16,91	HA62	90L/90LA	4	6238
80,8	172	1,6	11,51	H052	100L/100LA	6	8000
79,7	174	1,2	11,67	HA52	100L/100LA	6	4280
79,7	174	1,8	11,67	HA62	100L/100LA	6	6317
79,6	175	2,7	11,69	H062	100L/100LA	6	12000
78,8	176	1,0	11,80	H042	100L/100LA	6	6270
77,8	177	1,9	18,00	H052	90L/90LA	4	8000
73,4	189	2,7	12,67	H062	100L/100LA	6	12000
70,1	196	1,7	19,97	H052	90L/90LA	4	8000
68,4	201	1,0	20,46	HA52	90L/90LA	4	4504
68,4	201	1,7	20,46	HA62	90L/90LA	4	6647
65,3	213	1,5	14,24	H052	100L/100LA	6	8000
64,6	213	1,6	21,67	H052	90L/90LA	4	8000
64,1	217	1,4	14,50	HA62	100L/100LA	6	6792
63,1	220	2,3	14,75	H062	100L/100LA	6	12000
60,2	229	2,7	23,27	H062	90L/90LA	4	12000
57,1	243	2,4	16,29	H062	100L/100LA	6	12000
56,7	243	1,4	24,71	H052	90L/90LA	4	8000
56,0	248	1,3	16,59	H052	100L/100LA	6	8000

6.1 H/HA GEARED MOTORS (50Hz)

1,50 kW

n2 [rpm]	M2 [Nm]	fs	i	Gear reducer	Motor Size	Pole	Fr2 [N]
55,1	250	1,2	25,43	HA62	90L/90LA	4	7147
55,0	253	1,4	16,91	HA62	100L/100LA	6	7150
54,5	252	2,4	25,70	H062	90L/90LA	4	12000
53,5	257	1,4	26,18	H052	90L/90LA	4	8000
52,6	264	2,3	17,67	H062	100L/100LA	6	12000
51,7	269	1,2	18,00	H052	100L/100LA	6	8000
49,2	279	1,3	28,44	H052	90L/90LA	4	8000
47,7	288	2,0	29,33	H062	90L/90LA	4	12000
46,8	294	1,1	29,89	HA62	90L/90LA	4	7543
46,6	298	1,1	19,97	H052	100L/100LA	6	8000
45,9	303	2,0	20,28	H062	100L/100LA	6	12000
45,5	306	1,1	20,46	HA62	100L/100LA	6	7618
44,4	310	1,4	31,52	H052	90L/90LA	4	8000
43,8	314	2,3	32,00	H062	90L/90LA	4	12000
42,9	324	1,0	21,67	H052	100L/100LA	6	8000
42,4	324	1,3	33,00	H052	90L/90LA	4	8000
40,0	348	1,8	23,27	H062	100L/100LA	6	12000
38,7	355	1,1	36,17	HA62	90L/90LA	4	8000
37,8	363	1,9	36,99	H062	90L/90LA	4	12000
36,2	384	1,6	25,70	H062	100L/100LA	6	12000
35,9	383	1,1	38,98	H052	90L/90LA	4	8000
34,7	396	1,8	40,33	H062	90L/90LA	4	12000
32,7	420	3,3	42,75	H082	90L/90LA	4	18000
31,7	438	1,3	29,33	H062	100L/100LA	6	12000
30,4	452	1,6	46,06	H062	90L/90LA	4	12000
29,9	465	2,9	31,15	H082	100L/100LA	6	18000
29,1	478	1,5	32,00	H062	100L/100LA	6	12000
29,1	473	2,9	48,13	H082	90L/90LA	4	18000
28,3	476	1,5	49,45	H063	90L/90LA	4	12000
27,1	513	2,7	34,38	H082	100L/100LA	6	18000
25,6	525	1,4	54,61	H063	90L/90LA	4	12000
25,1	552	1,2	36,99	H062	100L/100LA	6	12000
24,8	544	2,5	56,53	H083	90L/90LA	4	18000
24,0	578	2,4	38,70	H082	100L/100LA	6	18000
23,1	602	1,2	40,33	H062	100L/100LA	6	12000
21,8	638	2,1	42,75	H082	100L/100LA	6	18000
20,6	654	1,1	68,00	H063	90L/90LA	4	12000
20,2	688	1,1	46,06	H062	100L/100LA	6	12000
19,6	688	2,2	71,48	H083	90L/90LA	4	18000
19,3	719	1,9	48,13	H082	100L/100LA	6	18000
18,8	723	1,0	49,45	H063	100L/100LA	6	12000
17,8	759	2,0	78,87	H083	90L/90LA	4	18000

1,50 kW

n2 [rpm]	M2 [Nm]	fs	i	Gear reducer	Motor Size	Pole	Fr2 [N]
16,5	827	1,7	56,53	H083	100L/100LA	6	18000
16,4	823	1,9	85,56	H083	90L/90LA	4	18000
14,3	943	1,6	98,09	H083	90L/90LA	4	18000
13,3	1019	2,9	69,69	H103	100L/100LA	6	22000
13,0	1045	1,5	71,48	H083	100L/100LA	6	18000
12,4	1085	1,4	112,78	H083	90L/90LA	4	18000
11,8	1153	1,3	78,87	H083	100L/100LA	6	18000
11,7	1167	2,6	79,82	H103	100L/100LA	6	22000
11,3	1197	1,3	124,44	H083	90L/90LA	4	18000
11,1	1231	2,4	84,16	H103	100L/100LA	6	22000
10,9	1251	1,2	85,56	H083	100L/100LA	6	18000
10,3	1316	3,2	89,97	H123	100LA	6	30000
10,0	1365	2,2	93,36	H103	100L/100LA	6	22000
9,8	1367	1,1	142,15	H083	90L/90LA	4	18000
9,8	1379	2,2	143,42	H103	90L/90LA	4	22000
9,5	1434	1,1	98,09	H083	100L/100LA	6	18000
9,3	1463	2,0	100,07	H103	100L/100LA	6	22000
9,3	1467	2,9	100,29	H123	100L/100LA	6	30000
9,0	1489	1,0	154,76	H083	90L/90LA	4	18000
8,8	1529	1,0	162,35	H083	90L	4	18000
8,7	1547	1,9	160,82	H103	90L/90LA	4	22000
8,6	1584	2,7	108,34	H123	100L/100LA	6	30000
7,8	1735	2,5	118,62	H123	100L/100LA	6	30000
7,7	1767	1,7	120,84	H103	100L/100LA	6	22000
7,7	1742	1,7	181,07	H103	90L/90LA	4	22000
7,3	1874	2,3	128,18	H123	100L/100LA	6	30000
7,2	1868	1,6	194,21	H103	90L/90LA	4	22000
6,9	1960	1,5	134,06	H103	100L/100LA	6	22000
6,5	2097	1,4	143,42	H103	100L/100LA	6	22000
6,5	2072	1,4	215,45	H103	90L/90LA	4	22000
6,4	2117	2,0	144,79	H123	100L/100LA	6	30000
6,0	2270	1,9	155,22	H123	100L/100LA	6	30000
5,8	2352	1,3	160,82	H103	100L/100LA	6	22000
5,8	2333	1,1	242,59	H103	90L/90LA	4	22000
5,4	2527	1,7	172,80	H123	100L/100LA	6	30000
5,1	2648	1,1	181,07	H103	100L/100LA	6	22000
4,9	2767	1,5	189,19	H123	100L/100LA	6	30000
4,8	2840	1,1	194,21	H103	100L/100LA	6	22000
4,5	3033	1,4	207,43	H123	100L/100LA	6	30000
4,0	3377	1,3	230,92	H123	100L/100LA	6	30000
3,6	3797	1,1	259,64	H123	100L/100LA	6	30000

1,85 kW

n2 [rpm]	M2 [Nm]	fs	i	Gear reducer	Size	Motor Pole	Fr2 [N]
1100,0	16	2,2	1,27	HR051	90LB ⁽¹⁾	4	1757
986,4	17	2,9	1,42	HR051	90LB ⁽¹⁾	4	1814
973,9	18	1,2	1,44	HR041	90LB ⁽¹⁾	4	676
966,7	18	1,9	1,45	HA51	90LB ⁽¹⁾	4	1410
730,7	24	1,4	1,27	HR051	100LB	6	1976
697,5	25	3,1	1,33	HA61	100LB	6	2353
658,8	26	2,0	2,13	HR051	90LB ⁽¹⁾	4	2036
655,2	26	1,9	1,42	HR051	100LB	6	2037
560,0	31	2,5	2,50	HA61	90LB ⁽¹⁾	4	2531
544,4	31	1,9	2,57	HR051	90LB ⁽¹⁾	4	2145
442,1	39	1,8	3,17	HR051	90LB ⁽¹⁾	4	2267
442,1	39	2,9	3,17	HR061	90LB ⁽¹⁾	4	3414
437,6	40	1,3	2,13	HR051	100LB	6	2271
437,6	40	2,6	2,13	HR061	100LB	6	3423
379,7	45	1,7	3,69	HR051	90LB ⁽¹⁾	4	2358
379,7	45	2,8	3,69	HR061	90LB ⁽¹⁾	4	3573
372,0	47	1,7	2,50	HA61	100LB	6	2901
361,7	48	1,3	2,57	HR051	100LB	6	2384
361,7	48	2,1	2,57	HR061	100LB	6	3622
350,0	49	1,6	4,00	HR051	90LB ⁽¹⁾	4	2406
350,0	49	2,6	4,00	HR061	90LB ⁽¹⁾	4	3659
319,3	54	1,8	4,38	HA61	90LB ⁽¹⁾	4	3053
298,1	57	1,2	4,70	H032	90LB ⁽¹⁾	4	3417
293,7	59	1,2	3,17	HR051	100LB	6	2500
293,7	59	1,9	3,17	HR061	100LB	6	3700
293,5	58	1,4	4,77	HR051	90LB ⁽¹⁾	4	2500
293,5	58	2,3	4,77	HR061	90LB ⁽¹⁾	4	3700
272,2	62	2,8	5,14	HA52	90LB ⁽¹⁾	4	2842
266,7	64	1,3	5,25	HR051	90LB ⁽¹⁾	4	2500
266,7	64	2,3	5,25	HR061	90LB ⁽¹⁾	4	3700
260,3	65	1,5	5,38	HA42	90LB ⁽¹⁾	4	2308
256,3	66	1,8	5,46	H042	90LB ⁽¹⁾	4	4690
252,2	69	1,1	3,69	HR051	100LB	6	2500
252,2	69	1,9	3,69	HR061	100LB	6	3700
244,4	69	2,7	5,73	H052	90LB ⁽¹⁾	4	6117
240,6	71	1,2	5,82	HR051	90LB ⁽¹⁾	4	2500
240,6	71	2,0	5,82	HR061	90LB ⁽¹⁾	4	3700
232,5	74	1,0	4,00	HR051	100LB	6	2500
232,5	74	1,7	4,00	HR061	100LB	6	3700
225,0	75	2,3	6,22	HA52	90LB ⁽¹⁾	4	3029
224,7	75	1,0	6,23	H032	90LB ⁽¹⁾	4	3616
214,8	79	1,3	6,52	HA42	90LB ⁽¹⁾	4	2461

⁽¹⁾ Available only with brake motor (TBS)

1,85 kW

n2 [rpm]	M2 [Nm]	fs	i	Gear reducer	Size	Motor Pole	Fr2 [N]
212,1	82	1,2	4,38	HA61	100LB	6	3499
203,1	84	2,5	6,89	H052	90LB ⁽¹⁾	4	6438
199,3	87	3,1	4,67	HR081	100LB	6	4000
195,0	89	1,5	4,77	HR061	100LB	6	3700
194,8	87	1,3	7,19	H042	90LB ⁽¹⁾	4	5013
190,9	90	1,6	7,33	HR061	90LB ⁽¹⁾	4	3700
186,7	92	3,2	7,50	HR081	90LB ⁽¹⁾	4	4000
181,0	94	1,8	7,73	HA52	90LB ⁽¹⁾	4	3256
180,8	95	1,8	5,14	HA52	100LB	6	3257
177,1	98	1,5	5,25	HR061	100LB	6	3700
170,3	101	1,2	5,46	H042	100LB	6	5162
167,9	103	2,7	5,54	HR081	100LB	6	4000
167,2	103	1,4	8,38	HR061	90LB ⁽¹⁾	4	3700
165,8	103	2,9	8,44	HR081	90LB ⁽¹⁾	4	4000
164,2	103	2,4	8,53	H052	90LB ⁽¹⁾	4	6815
162,4	105	1,8	5,73	H052	100LB	6	6827
159,8	108	1,3	5,82	HR061	100LB	6	3700
157,1	108	1,4	8,91	H042	90LB ⁽¹⁾	4	5262
152,9	113	2,6	6,08	HR081	100LB	6	4000
149,5	115	1,5	6,22	HA52	100LB	6	3471
149,5	115	2,4	6,22	HA62	100LB	6	5123
146,4	116	2,3	9,56	H052	90LB ⁽¹⁾	4	7020
145,2	117	1,8	9,64	HA52	90LB ⁽¹⁾	4	3505
145,2	117	2,8	9,64	HA62	90LB ⁽¹⁾	4	5173
135,7	125	1,4	10,31	H042	90LB ⁽¹⁾	4	5425
134,9	127	1,6	6,89	H052	100LB	6	7159
126,8	136	1,1	7,33	HR061	100LB	6	3700
124,0	140	2,1	7,50	HR081	100LB	6	4000
121,6	139	2,0	11,51	H052	90LB ⁽¹⁾	4	7354
120,3	142	1,2	7,73	HA52	100LB	6	3732
120,3	142	1,9	7,73	HA62	100LB	6	5508
120,0	141	1,4	11,67	HA52	90LB ⁽¹⁾	4	3735
120,0	141	2,2	11,67	HA62	90LB ⁽¹⁾	4	5512
118,6	143	1,3	11,80	H042	90LB ⁽¹⁾	4	5569
110,1	157	1,9	8,44	HR081	100LB	6	4000
109,1	157	1,6	8,53	H052	100LB	6	7540
103,2	164	1,1	13,57	H042	90LB ⁽¹⁾	4	5710
99,1	173	2,5	9,39	H062	100LB	6	12000
98,3	172	1,8	14,24	H052	90LB ⁽¹⁾	4	7736
97,3	176	1,5	9,56	H052	100LB	6	7744
96,6	176	1,1	14,50	HA52	90LB ⁽¹⁾	4	4015
96,6	176	1,7	14,50	HA62	90LB ⁽¹⁾	4	5926

⁽¹⁾ Available only with brake motor (TBS)

1,85 kW

n2 [rpm]	M2 [Nm]	fs	i	Gear reducer	Size	Motor Pole	Fr2 [N]
96,4	178	1,2	9,64	HA52	100LB	6	4017
96,4	178	1,9	9,64	HA62	100LB	6	5929
94,9	179	2,8	14,75	H062	90LB ⁽¹⁾	4	12000
84,4	201	1,6	16,59	H052	90LB ⁽¹⁾	4	8000
82,8	205	1,1	16,91	HA52	90LB ⁽¹⁾	4	4227
82,8	205	1,8	16,91	HA62	90LB ⁽¹⁾	4	6238
80,8	212	1,3	11,51	H052	100LB	6	8000
79,7	215	1,5	11,67	HA62	100LB	6	6317
79,6	215	2,2	11,69	H062	100LB	6	12000
79,2	214	2,8	17,67	H062	90LB ⁽¹⁾	4	12000
77,8	218	1,5	18,00	H052	90LB ⁽¹⁾	4	8000
73,4	233	2,2	12,67	H062	100LB	6	12000
70,1	242	1,4	19,97	H052	90LB ⁽¹⁾	4	8000
69,0	246	2,5	20,28	H062	90LB ⁽¹⁾	4	12000
68,4	248	1,3	20,46	HA62	90LB ⁽¹⁾	4	6647
65,3	262	1,2	14,24	H052	100LB	6	8000
64,6	262	1,3	21,67	H052	90LB ⁽¹⁾	4	8000
64,1	267	1,1	14,50	HA62	100LB	6	6792
63,1	272	1,9	14,75	H062	100LB	6	12000
60,2	282	2,2	23,27	H062	90LB ⁽¹⁾	4	12000
57,1	300	1,9	16,29	H062	100LB	6	12000
56,7	299	1,1	24,71	H052	90LB ⁽¹⁾	4	8000
56,0	306	1,1	16,59	H052	100LB	6	8000
55,1	308	1,0	25,43	HA62	90LB ⁽¹⁾	4	7147
55,0	312	1,2	16,91	HA62	100LB	6	7150
54,5	311	2,0	25,70	H062	90LB ⁽¹⁾	4	12000
53,5	317	1,1	26,18	H052	90LB ⁽¹⁾	4	8000
52,6	325	1,8	17,67	H062	100LB	6	12000
51,7	332	1,0	18,00	H052	100LB	6	8000
49,2	345	1,0	28,44	H052	90LB ⁽¹⁾	4	8000
47,7	355	1,6	29,33	H062	90LB ⁽¹⁾	4	12000
45,9	374	1,6	20,28	H062	100LB	6	12000
44,4	382	1,1	31,52	H052	90LB ⁽¹⁾	4	8000
43,8	388	1,9	32,00	H062	90LB ⁽¹⁾	4	12000
42,4	400	1,0	33,00	H052	90LB ⁽¹⁾	4	8000
40,7	416	3,3	34,38	H082	90LB ⁽¹⁾	4	18000
40,0	429	1,4	23,27	H062	100LB	6	12000
37,8	448	1,5	36,99	H062	90LB ⁽¹⁾	4	12000
36,2	473	1,3	25,70	H062	100LB	6	12000
36,2	469	2,9	38,70	H082	90LB ⁽¹⁾	4	18000
35,0	490	2,4	26,60	H082	100LB	6	18000
34,7	489	1,5	40,33	H062	90LB ⁽¹⁾	4	12000

⁽¹⁾ Available only with brake motor (TBS)

1,85 kW

n2 [rpm]	M2 [Nm]	fs	i	Gear reducer	Size	Motor Pole	Fr2 [N]
33,4	514	2,2	27,88	H082	100LB	6	18000
32,7	518	2,6	42,75	H082	90LB ⁽¹⁾	4	18000
31,7	540	1,1	29,33	H062	100LB	6	12000
30,4	558	1,3	46,06	H062	90LB ⁽¹⁾	4	12000
29,9	574	2,4	31,15	H082	100LB	6	18000
29,1	589	1,2	32,00	H062	100LB	6	12000
29,1	583	2,3	48,13	H082	90LB ⁽¹⁾	4	18000
28,3	587	1,2	49,45	H063	90LB ⁽¹⁾	4	12000
27,1	633	2,2	34,38	H082	100LB	6	18000
25,6	648	1,1	54,61	H063	90LB ⁽¹⁾	4	12000
24,8	671	2,0	56,53	H083	90LB ⁽¹⁾	4	18000
24,0	713	1,9	38,70	H082	100LB	6	18000
21,8	787	1,7	42,75	H082	100LB	6	18000
19,6	848	1,8	71,48	H083	90LB ⁽¹⁾	4	18000
19,3	887	1,5	48,13	H082	100LB	6	18000
18,1	949	3,0	51,52	H102	100LB	6	22000
17,8	936	1,6	78,87	H083	90LB ⁽¹⁾	4	18000
16,5	1019	1,3	56,53	H083	100LB	6	18000
16,4	1015	1,5	85,56	H083	90LB ⁽¹⁾	4	18000
14,3	1164	1,3	98,09	H083	90LB ⁽¹⁾	4	18000
13,3	1257	2,4	69,69	H103	100LB	6	22000
13,0	1289	1,2	71,48	H083	100LB	6	18000
12,6	1329	3,2	73,71	H123	100LB	6	30000
12,4	1338	1,1	112,78	H083	90LB ⁽¹⁾	4	18000
11,8	1423	1,1	78,87	H083	100LB	6	18000
11,7	1440	2,1	79,82	H103	100LB	6	22000
11,3	1476	1,0	124,44	H083	90LB ⁽¹⁾	4	18000
11,2	1503	2,8	83,34	H123	100LB	6	30000
11,1	1518	2,0	84,16	H103	100LB	6	22000
10,3	1623	2,6	89,97	H123	100LB	6	30000
10,0	1684	1,8	93,36	H103	100LB	6	22000
9,8	1701	1,8	143,42	H103	90LB ⁽¹⁾	4	22000
9,3	1805	1,7	100,07	H103	100LB	6	22000
9,3	1809	2,4	100,29	H123	100LB	6	30000
8,7	1908	1,6	160,82	H103	90LB ⁽¹⁾	4	22000
8,6	1954	2,2	108,34	H123	100LB	6	30000
7,8	2139	2,0	118,62	H123	100LB	6	30000
7,7	2179	1,4	120,84	H103	100LB	6	22000
7,7	2148	1,4	181,07	H103	90LB ⁽¹⁾	4	22000
7,3	2312	1,8	128,18	H123	100LB	6	30000
7,2	2304	1,3	194,21	H103	90LB ⁽¹⁾	4	22000
6,9	2418	1,2	134,06	H103	100LB	6	22000

⁽¹⁾ Available only with brake motor (TBS)

1,85 kW

n2 [rpm]	M2 [Nm]	fs	i	Gear reducer	Motor Size	Pole	Fr2 [N]
6,5	2587	1,2	143,42	H103	100LB	6	22000
6,5	2556	1,2	215,45	H103	90LB ⁽¹⁾	4	22000
6,4	2611	1,6	144,79	H123	100LB	6	30000
6,0	2800	1,5	155,22	H123	100LB	6	30000
5,8	2901	1,0	160,82	H103	100LB	6	22000
5,4	3117	1,4	172,80	H123	100LB	6	30000
4,9	3412	1,3	189,19	H123	100LB	6	30000
4,5	3741	1,1	207,43	H123	100LB	6	30000
4,0	4165	1,0	230,92	H123	100LB	6	30000

2,20 kW

n2 [rpm]	M2 [Nm]	fs	i	Gear reducer	Motor Size	Pole	Fr2 [N]
1123,6	18	1,9	1,27	HR051	100LA/112MR	4	1729
1007,5	20	2,5	1,42	HR051	100LA/112MR	4	1784
730,7	28	1,2	1,27	HR051	112M/112MA	6	1949
697,5	30	2,6	1,33	HA61	112M/112MA	6	2353
692,1	30	2,3	1,34	HR061	112M/112MA	6	2960
672,9	30	1,7	2,13	HR051	100LA/112MR	4	1995
655,2	31	1,6	1,42	HR051	112M/112MA	6	2007
572,0	36	2,2	2,50	HA61	100LA/112MR	4	2514
556,1	37	1,6	2,57	HR051	100LA/112MR	4	2098
556,1	37	2,8	2,57	HR061	100LA/112MR	4	3162
451,6	45	1,5	3,17	HR051	100LA/112MR	4	2212
451,6	45	2,5	3,17	HR061	100LA/112MR	4	3364
437,6	47	1,1	2,13	HR051	112M/112MA	6	2226
437,6	47	2,2	2,13	HR061	112M/112MA	6	3393
387,8	53	1,5	3,69	HR051	100LA/112MR	4	2295
387,8	53	2,4	3,69	HR061	100LA/112MR	4	3517
372,0	55	1,4	2,50	HA61	112M/112MA	6	2901
361,7	57	1,1	2,57	HR051	112M/112MA	6	2329
361,7	57	1,8	2,57	HR061	112M/112MA	6	3586
357,5	57	1,4	4,00	HR051	100LA/112MR	4	2339
357,5	57	2,2	4,00	HR061	100LA/112MR	4	3601
323,9	63	1,5	4,38	HA61	100LA/112MR	4	3038
303,2	68	1,0	3,17	HR051	112M	6	2423
302,4	67	1,0	4,70	H032	100LA/112MR	4	3297
299,8	68	1,2	4,77	HR051	100LA/112MR	4	2433
299,8	68	2,0	4,77	HR061	100LA/112MR	4	3700
293,7	70	1,6	3,17	HR061	112M/112MA	6	3700
278,1	73	2,4	5,14	HA52	100LA/112MR	4	2822
272,4	75	1,1	5,25	HR051	100LA/112MR	4	2483

⁽¹⁾ Available only with brake motor (TBS)

2,20 kW

n2 [rpm]	M2 [Nm]	fs	i	Gear reducer	Motor Size	Pole	Fr2 [N]
272,4	75	1,9	5,25	HR061	100LA/112MR	4	3700
260,0	78	1,5	5,46	H042	100LA/112MR	4	4571
252,2	82	1,6	3,69	HR061	112M/112MA	6	3700
249,7	81	2,3	5,73	H052	100LA/112MR	4	5995
244,1	84	1,0	5,82	HR051	100LA/112MR	4	2500
244,1	84	1,7	5,82	HR061	100LA/112MR	4	3700
235,1	87	3,3	6,08	HR081	100LA	4	4000
232,5	89	1,4	4,00	HR061	112M/112MA	6	3700
232,5	89	3,1	4,00	HR081	112M/112MA	6	4000
229,8	88	2,0	6,22	HA52	100LA/112MR	4	3007
206,0	98	2,1	6,89	H052	100LA/112MR	4	6309
199,3	103	2,6	4,67	HR081	112M/112MA	6	4000
197,6	102	1,1	7,19	H042	100LA/112MR	4	4862
195,0	106	1,3	4,77	HR061	112M/112MA	6	3700
195,0	105	1,4	7,33	HR061	100LA/112MR	4	3700
189,3	108	2,8	7,50	HR081	100LA/112MR	4	4000
183,6	110	1,6	7,73	HA52	100LA/112MR	4	3241
183,6	110	2,5	7,73	HA62	100LA/112MR	4	4783
180,8	113	1,5	5,14	HA52	112M/112MA	6	3257
180,8	113	2,4	5,14	HA62	112M/112MA	6	4808
177,1	116	1,2	5,25	HR061	112M/112MA	6	3700
175,7	116	1,0	5,46	H042	112M	6	4972
169,6	120	1,2	8,38	HR061	100LA/112MR	4	3700
168,2	121	2,5	8,44	HR081	100LA/112MR	4	4000
167,9	123	2,3	5,54	HR081	112M/112MA	6	4000
166,5	121	2,0	8,53	H052	100LA/112MR	4	6660
162,4	125	1,5	5,73	H052	112M/112MA	6	6694
159,8	129	1,1	5,82	HR061	112M/112MA	6	3700
159,3	127	1,2	8,91	H042	100LA/112MR	4	5079
152,9	135	2,2	6,08	HR081	112M/112MA	6	4000
149,5	136	1,3	6,22	HA52	112M/112MA	6	3471
149,5	136	2,0	6,22	HA62	112M/112MA	6	5123
148,5	136	2,0	9,56	H052	100LA/112MR	4	6850
147,3	137	1,6	9,64	HA52	100LA/112MR	4	3488
147,3	137	2,4	9,64	HA62	100LA/112MR	4	5149
137,7	147	1,2	10,31	H042	100LA/112MR	4	5216
134,9	151	1,4	6,89	H052	112M/112MA	6	6998
125,8	162	2,4	7,39	H062	112M/112MA	6	12000
124,0	166	1,8	7,50	HR081	112M/112MA	6	4000
123,4	163	1,7	11,51	H052	100LA/112MR	4	7155
121,7	166	1,2	11,67	HA52	100LA/112MR	4	3717
121,7	166	1,9	11,67	HA62	100LA/112MR	4	5486

6.1 H/HA GEARED MOTORS (50Hz)

2,20 kW

n2 [rpm]	M2 [Nm]	fs	i	Gear reducer	Motor Size	Pole	Fr2 [N]
121,5	166	2,8	11,69	H062	100LA	4	12000
120,3	168	1,1	11,80	H042	100LA/112MR	4	5333
120,3	169	1,0	7,73	HA52	112M/112MA	6	3732
120,3	169	1,6	7,73	HA62	112M/112MA	6	5508
112,1	180	2,8	12,67	H062	100LA	4	12000
110,7	186	3,0	8,40	HR101	112M/112MA	6	5000
110,1	187	1,6	8,44	HR081	112M/112MA	6	4000
109,4	186	2,3	8,50	H062	112M/112MA	6	12000
109,1	187	1,3	8,53	H052	112M/112MA	6	7341
100,7	200	1,0	14,50	HA52	112MR	4	3959
99,7	202	1,5	14,24	H052	100LA/112MR	4	7495
99,1	206	2,1	9,39	H062	112M/112MA	6	12000
97,9	206	1,5	14,50	HA62	100LA/112MR	4	5898
97,3	209	1,3	9,56	H052	112M/112MA	6	7521
96,4	211	1,0	9,64	HA52	112M/112MA	6	4017
96,4	211	1,6	9,64	HA62	112M/112MA	6	5929
96,3	210	2,4	14,75	H062	100LA/112MR	4	12000
87,2	231	2,5	16,29	H062	100LA/112MR	4	12000
85,6	236	1,4	16,59	H052	100LA/112MR	4	7730
84,0	240	1,5	16,91	HA62	100LA/112MR	4	6209
80,8	252	1,1	11,51	H052	112M/112MA	6	7799
80,4	251	2,4	17,67	H062	100LA/112MR	4	12000
79,7	256	1,2	11,67	HA62	112M/112MA	6	6317
79,6	256	1,8	11,69	H062	112M/112MA	6	12000
78,9	256	1,3	18,00	H052	100LA/112MR	4	7850
73,4	277	1,8	12,67	H062	112M/112MA	6	12000
71,1	284	1,2	19,97	H052	100LA/112MR	4	7997
70,0	288	2,1	20,28	H062	100LA/112MR	4	12000
69,4	291	1,1	20,46	HA62	100LA/112MR	4	6616
67,4	302	1,0	14,24	H052	112M	6	8000
65,5	308	1,1	21,67	H052	100LA/112MR	4	8000
63,1	323	1,6	14,75	H062	112M/112MA	6	12000
61,0	331	1,8	23,27	H062	100LA/112MR	4	12000
57,1	357	1,6	16,29	H062	112M/112MA	6	12000
56,8	359	1,0	16,91	HA62	112M	6	7074
55,3	365	1,7	25,70	H062	100LA/112MR	4	12000
52,6	387	1,6	17,67	H062	112M/112MA	6	12000
50,2	406	2,7	18,53	H082	112MA	6	18000
48,4	417	1,4	29,33	H062	100LA/112MR	4	12000
48,0	425	2,7	19,38	H082	112MA	6	18000
45,9	444	1,4	20,28	H062	112M/112MA	6	12000
45,6	443	3,1	31,15	H082	100LA/112MR	4	18000

2,20 kW

n2 [rpm]	M2 [Nm]	fs	i	Gear reducer	Motor Size	Pole	Fr2 [N]
44,4	455	1,6	32,00	H062	100LA/112MR	4	12000
43,5	469	2,5	21,39	H082	112M/112MA	6	18000
41,3	488	2,8	34,38	H082	100LA/112MR	4	18000
40,8	499	2,3	22,80	H082	112M/112MA	6	18000
40,0	510	1,2	23,27	H062	112M/112MA	6	12000
38,4	525	1,3	36,99	H062	100LA/112MR	4	12000
36,7	550	2,5	38,70	H082	100LA/112MR	4	18000
36,2	563	1,1	25,70	H062	112M/112MA	6	12000
35,2	573	1,3	40,33	H062	100LA/112MR	4	12000
35,0	583	2,0	26,60	H082	112M/112MA	6	18000
33,4	611	1,9	27,88	H082	112M/112MA	6	18000
33,2	607	2,2	42,75	H082	100LA/112MR	4	18000
30,8	654	1,1	46,06	H062	100LA/112MR	4	12000
29,9	682	2,0	31,15	H082	112M/112MA	6	18000
29,5	684	2,0	48,13	H082	100LA/112MR	4	18000
29,1	701	1,0	32,00	H062	112M/112MA	6	12000
28,7	688	1,1	49,45	H063	100LA/112MR	4	12000
27,1	753	1,8	34,38	H082	112M/112MA	6	18000
25,1	786	1,7	56,53	H083	100LA/112MR	4	18000
24,2	842	2,8	38,45	H102	112M/112MA	6	22000
24,0	848	1,6	38,70	H082	112M/112MA	6	18000
22,5	905	3,1	41,30	H102	112M/112MA	6	22000
21,8	936	1,5	42,75	H082	112M/112MA	6	18000
20,4	969	3,1	69,69	H103	100LA/112MR	4	22000
20,3	1004	2,8	45,82	H102	112M/112MA	6	22000
19,9	994	1,5	71,48	H083	100LA/112MR	4	18000
19,3	1054	1,3	48,13	H082	112M/112MA	6	18000
18,1	1128	2,5	51,52	H102	112M/112MA	6	22000
18,0	1097	1,4	78,87	H083	100LA/112MR	4	18000
17,8	1110	2,7	79,82	H103	100LA/112MR	4	22000
16,9	1170	2,6	84,16	H103	100LA/112MR	4	22000
16,6	1190	1,3	85,56	H083	100LA/112MR	4	18000
16,5	1212	1,1	56,53	H083	112M/112MA	6	18000
15,8	1251	3,4	89,97	H123	100LA ⁽¹⁾	4	30000
15,2	1299	2,3	93,36	H103	100LA/112MR	4	22000
14,5	1364	1,1	98,09	H083	100LA/112MR	4	18000
14,2	1392	2,1	100,07	H103	100LA/112MR	4	22000
14,2	1395	3,1	100,29	H123	100LA/112MR	4	30000
13,8	1444	3,0	67,32	H123	112M/112MA	6	30000
13,3	1495	2,0	69,69	H103	112M/112MA	6	22000
13,1	1507	2,8	108,34	H123	100LA/112MR	4	30000
13,0	1533	1,0	71,48	H083	112M/112MA	6	18000

⁽¹⁾ Available only with brake motor (TBS)

6.1 H/HA GEARED MOTORS (50Hz)

2,20 kW

n2 [rpm]	M2 [Nm]	fs	i	Gear reducer	Motor Size	Pole	Fr2 [N]
12,9	1526	1,0	112,78	H083	112MR	4	18000
12,6	1581	2,7	73,71	H123	112M/112MA	6	30000
12,0	1650	2,6	118,62	H123	100LA/112MR	4	30000
11,8	1681	1,8	120,84	H103	100LA/112MR	4	22000
11,7	1712	1,7	79,82	H103	112M/112MA	6	22000
11,2	1787	2,4	83,34	H123	112M/112MA	6	30000
11,1	1805	1,7	84,16	H103	112M/112MA	6	22000
11,1	1783	2,4	128,18	H123	100LA/112MR	4	30000
10,6	1865	1,6	134,06	H103	100LA/112MR	4	22000
10,3	1930	2,2	89,97	H123	112M/112MA	6	30000
10,0	2002	1,5	93,36	H103	112M/112MA	6	22000
9,9	1995	1,5	143,42	H103	100LA/112MR	4	22000
9,8	2014	2,1	144,79	H123	100LA/112MR	4	30000
9,3	2146	1,4	100,07	H103	112M/112MA	6	22000
9,3	2151	2,0	100,29	H123	112M/112MA	6	30000
9,1	2159	2,0	155,22	H123	100LA/112MR	4	30000
8,8	2237	1,3	160,82	H103	100LA/112MR	4	22000
8,6	2324	1,8	108,34	H123	112M/112MA	6	30000
8,2	2403	1,8	172,80	H123	100LA/112MR	4	30000
7,8	2518	1,2	181,07	H103	100LA/112MR	4	22000
7,8	2544	1,7	118,62	H123	112M/112MA	6	30000
7,7	2592	1,2	120,84	H103	112M/112MA	6	22000
7,5	2631	1,6	189,19	H123	100LA/112MR	4	30000
7,3	2701	1,1	194,21	H103	100LA/112MR	4	22000
7,3	2749	1,6	128,18	H123	112M/112MA	6	30000
6,9	2875	1,0	134,06	H103	112M/112MA	6	22000
6,8	2885	1,5	207,43	H123	100LA/112MR	4	30000
6,7	2980	1,0	143,42	H103	112M	6	22000
6,6	2976	1,0	215,45	H103	100LA/112MR	4	22000
6,4	3105	1,4	144,79	H123	112M/112MA	6	30000
6,1	3212	1,3	230,92	H123	100LA/112MR	4	30000
6,0	3329	1,3	155,22	H123	112M/112MA	6	30000
5,5	3611	1,2	259,64	H123	100LA/112MR	4	30000
5,4	3706	1,2	172,80	H123	112M/112MA	6	30000
4,9	4058	1,1	189,19	H123	112M/112MA	6	30000

3,00 kW

n2 [rpm]	M2 [Nm]	fs	i	Gear reducer	Motor Size	Pole	Fr2 [N]
1123,6	25	1,4	1,27	HR051	100LB/112MS	4	1689
1072,5	26	3,0	1,33	HA61	100LB/112MS	4	2038
1064,2	26	2,5	1,34	HR061	100LB/112MS	4	2567

3,00 kW

n2 [rpm]	M2 [Nm]	fs	i	Gear reducer	Motor Size	Pole	Fr2 [N]
1007,5	28	1,8	1,42	HR051	100LB/112MS	4	1740
697,5	40	1,9	1,33	HA61	112MB	6	2353
692,1	41	1,7	1,34	HR061	112MB	6	2916
668,2	42	1,2	2,13	HR051	100LB/112MS	4	1932
668,2	42	2,5	2,13	HR061	100LB/112MS	4	2948
655,2	43	1,2	1,42	HR051	112MB	6	1938
572,0	49	1,6	2,50	HA61	100LB/112MS	4	2514
556,1	50	1,2	2,57	HR051	100LB/112MS	4	2017
556,1	50	2,0	2,57	HR061	100LB/112MS	4	3109
451,6	62	1,1	3,17	HR051	100LB/112MS	4	2113
451,6	62	1,8	3,17	HR061	100LB/112MS	4	3298
437,6	64	1,6	2,13	HR061	112MB	6	3325
387,8	72	1,1	3,69	HR051	100LB/112MS	4	2180
387,8	72	1,8	3,69	HR061	100LB/112MS	4	3441
372,0	75	1,0	2,50	HA61	112MB	6	2901
362,5	77	1,0	4,00	HR051	112MS	4	2208
361,7	78	1,3	2,57	HR061	112MB	6	3504
357,5	78	1,6	4,00	HR061	100LB/112MS	4	3518
323,9	86	1,1	4,38	HA61	100LB/112MS	4	3038
306,4	91	3,0	4,67	HR081	100LB/112MS	4	4000
299,8	93	1,5	4,77	HR061	100LB/112MS	4	3687
293,7	96	1,2	3,17	HR061	112MB	6	3700
286,2	98	2,7	3,25	HR081	112MB/132S/132SA	6	4000
276,1	100	1,7	5,14	HA52	100LB/112MS	4	2829
276,1	100	2,8	5,14	HA62	100LB/112MS	4	4175
270,5	103	1,4	5,25	HR061	100LB/112MS	4	3700
260,0	106	1,1	5,46	H042	100LB/112MS	4	4337
258,2	108	2,6	5,54	HR081	100LB/112MS	4	4000
252,2	111	1,2	3,69	HR061	112MB	6	3700
249,9	112	2,3	3,72	HR081	112MB/132S/132SA	6	4000
247,9	111	1,7	5,73	H052	100LB/112MS	4	5809
244,1	114	1,3	5,82	HR061	100LB/112MS	4	3700
233,4	119	2,4	6,08	HR081	100LB/112MS	4	4000
232,5	121	1,1	4,00	HR061	112MB	6	3700
232,5	121	2,3	4,00	HR081	112MB/132S/132SA	6	4000
228,2	121	1,4	6,22	HA52	100LB/112MS	4	3014
228,2	121	2,3	6,22	HA62	100LB/112MS	4	4449
206,0	134	1,6	6,89	H052	100LB/112MS	4	6071
199,3	141	1,9	4,67	HR081	112MB/132S/132SA	6	4000
193,6	144	1,0	7,33	HR061	100LB/112MS	4	3700
192,1	143	2,8	7,39	H062	100LB/112MS	4	11035
189,3	147	2,0	7,50	HR081	100LB/112MS	4	4000

3,00 kW

n2 [rpm]	M2 [Nm]	fs	i	Gear reducer	Motor Size	Pole	Fr2 [N]
183,6	150	1,2	7,73	HA52	100LB/112MS	4	3241
183,6	150	1,8	7,73	HA62	100LB/112MS	4	4783
180,8	154	1,1	5,14	HA52	112MB	6	3257
180,8	154	1,8	5,14	HA62	112MB	6	4808
173,0	161	2,2	5,38	H062	112MB/132S/132SA	6	11351
169,0	164	3,4	8,40	HR101	100LB	4	5000
168,2	165	1,8	8,44	HR081	100LB/112MS	4	4000
167,9	167	1,7	5,54	HR081	112MB/132S/132SA	6	4000
167,1	165	2,6	8,50	H062	100LB/112MS	4	11470
166,5	165	1,5	8,53	H052	100LB/112MS	4	6366
162,4	171	1,1	5,73	H052	112MB	6	6389
156,7	177	2,2	5,93	H062	112MB/132S/132SA	6	11662
152,9	184	1,6	6,08	HR081	112MB/132S/132SA	6	4000
151,3	182	2,4	9,39	H062	100LB/112MS	4	11783
149,5	186	1,5	6,22	HA62	112MB	6	5123
149,3	188	2,9	6,23	HR101	112MB/132S/132SA	6	5000
148,5	185	1,4	9,56	H052	100LB/112MS	4	6520
147,3	187	1,2	9,64	HA52	100LB/112MS	4	3488
147,3	187	1,8	9,64	HA62	100LB/112MS	4	5149
134,9	206	1,0	6,89	H052	112MB	6	6632
129,8	214	2,7	7,39	H082	132S/132SA	6	15421
125,8	221	1,8	7,39	H062	112MB/132S/132SA	6	12000
124,0	226	1,3	7,50	HR081	112MB/132S/132SA	6	4000
123,4	223	1,3	11,51	H052	100LB/112MS	4	6758
123,3	228	2,4	7,55	HR101	112MB/132S/132SA	6	5000
121,7	226	1,4	11,67	HA62	100LB/112MS	4	5486
121,5	226	2,1	11,69	H062	100LB/112MS	4	12000
120,3	231	1,2	7,73	HA62	112MB	6	5508
119,7	232	2,5	8,02	H082	132S/132SA	6	15784
112,1	245	2,1	12,67	H062	100LB/112MS	4	12000
110,7	254	2,2	8,40	HR101	112MB/132S/132SA	6	5000
110,1	255	1,2	8,44	HR081	112MB/132S/132SA	6	4000
109,4	254	1,7	8,50	H062	112MB/132S/132SA	6	12000
108,5	256	2,5	8,85	H082	132S/132SA	6	16230
99,7	276	1,1	14,24	H052	100LB/112MS	4	7004
99,1	280	1,5	9,39	H062	112MB/132S/132SA	6	12000
97,9	281	1,1	14,50	HA62	100LB/112MS	4	5898
96,4	288	1,2	9,64	HA62	112MB	6	5929
96,3	286	1,8	14,75	H062	100LB/112MS	4	12000
87,2	315	1,8	16,29	H062	100LB/112MS	4	12000
87,2	319	2,5	11,01	H082	132S/132SA	6	17243
85,6	321	1,0	16,59	H052	100LB/112MS	4	7158

3,00 kW

n2 [rpm]	M2 [Nm]	fs	i	Gear reducer	Motor Size	Pole	Fr2 [N]
84,0	328	1,1	16,91	HA62	100LB/112MS	4	6209
80,4	342	1,8	17,67	H062	100LB/112MS	4	12000
79,6	349	1,3	11,69	H062	112MB/132S/132SA	6	12000
73,4	378	1,3	12,67	H062	112MB/132S/132SA	6	12000
70,0	393	1,6	20,28	H062	100LB/112MS	4	12000
68,9	403	2,5	13,50	H082	112MB/132S/132SA	6	18000
66,4	414	2,8	21,39	H082	100LB/112MS	4	18000
63,1	441	1,1	14,75	H062	112MB/132S/132SA	6	12000
62,4	445	2,4	14,90	H082	112MB/132S/132SA	6	18000
62,3	442	2,6	22,80	H082	100LB/112MS	4	18000
61,0	451	1,4	23,27	H062	100LB/112MS	4	12000
57,1	486	1,2	16,29	H062	112MB/132S/132SA	6	12000
56,0	496	2,2	16,62	H082	112MB/132S/132SA	6	18000
55,3	498	1,2	25,70	H062	100LB/112MS	4	12000
53,4	515	2,2	26,60	H082	100LB/112MS	4	18000
52,6	528	1,1	17,67	H062	112MB/132S/132SA	6	12000
50,9	540	2,1	27,88	H082	100LB/112MS	4	18000
50,2	553	2,0	18,53	H082	112MB/132S/132SA	6	18000
48,4	568	1,0	29,33	H062	100LB/112MS	4	12000
48,0	579	2,0	19,38	H082	112MB/132S/132SA	6	18000
45,9	606	1,0	20,28	H062	112MB/132S/132SA	6	12000
45,6	603	2,3	31,15	H082	100LB/112MS	4	18000
44,4	620	1,2	32,00	H062	100LB/112MS	4	12000
43,5	639	1,8	21,39	H082	112MB/132S/132SA	6	18000
41,3	666	2,1	34,38	H082	100LB/112MS	4	18000
40,8	681	1,7	22,80	H082	112MB/132S/132SA	6	18000
36,9	745	3,2	38,45	H102	100LB/112MS	4	22000
36,7	750	1,8	38,70	H082	100LB/112MS	4	18000
35,0	795	1,5	26,60	H082	112MB/132S/132SA	6	18000
33,4	833	1,4	27,88	H082	112MB/132S/132SA	6	18000
33,2	828	1,6	42,75	H082	100LB/112MS	4	18000
31,0	887	3,2	45,82	H102	100LB/112MS	4	22000
30,3	918	3,0	30,72	H102	112MB/132S/132SA	6	22000
29,9	931	1,5	31,15	H082	112MB/132S/132SA	6	18000
29,5	932	1,5	48,13	H082	100LB/112MS	4	18000
27,6	998	2,8	51,52	H102	100LB/112MS	4	22000
27,2	1022	2,7	34,20	H102	112MB/132S/132SA	6	22000
27,1	1027	1,3	34,38	H082	112MB/132S/132SA	6	18000
25,1	1072	1,3	56,53	H083	100LB/112MS	4	18000
24,2	1149	2,1	38,45	H102	112MB/132S/132SA	6	22000
24,0	1156	1,2	38,70	H082	112MB/132S/132SA	6	18000
22,5	1234	2,3	41,30	H102	112MB/132S/132SA	6	22000

3,00 kW

n2 [rpm]	M2 [Nm]	fs	i	Gear reducer	Motor Size	Pole	Fr2 [N]
21,8	1277	1,1	42,75	H082	112MB/132S/132SA	6	18000
21,1	1277	3,3	67,32	H123	100LB/112MS	4	30000
20,4	1322	2,3	69,69	H103	100LB/112MS	4	22000
20,3	1369	2,1	45,82	H102	112MB/132S/132SA	6	22000
19,9	1356	1,1	71,48	H083	100LB/112MS	4	18000
19,3	1398	3,1	73,71	H123	100LB/112MS	4	30000
18,1	1539	1,8	51,52	H102	112MB/132S/132SA	6	22000
18,0	1496	1,0	78,87	H083	100LB/112MS	4	18000
17,8	1514	2,0	79,82	H103	100LB/112MS	4	22000
17,3	1572	1,9	55,47	H103	132S/132SA	6	22000
17,2	1583	2,7	55,87	H123	132S/132SA	6	30000
17,0	1580	2,7	83,34	H123	100LB/112MS	4	30000
16,9	1596	1,9	84,16	H103	100LB/112MS	4	22000
15,8	1706	2,5	89,97	H123	100LB/112MS	4	30000
15,2	1771	1,7	93,36	H103	100LB/112MS	4	22000
14,2	1898	1,6	100,07	H103	100LB/112MS	4	22000
14,2	1902	2,2	100,29	H123	100LB/112MS	4	30000
13,8	1969	2,2	67,32	H123	112MB/132S/132SA	6	30000
13,3	2038	1,5	69,69	H103	112MB/132S/132SA	6	22000
13,1	2055	2,1	108,34	H123	100LB/112MS	4	30000
12,6	2156	2,0	73,71	H123	112MB/132S/132SA	6	30000
12,1	2240	3,1	79,07	H143	132S/132SA	6	55000
12,0	2250	1,9	118,62	H123	100LB/112MS	4	30000
11,8	2292	1,3	120,84	H103	100LB/112MS	4	22000
11,7	2334	1,3	79,82	H103	112MB/132S/132SA	6	22000
11,2	2437	1,8	83,34	H123	112MB/132S/132SA	6	30000
11,1	2461	1,2	84,16	H103	112MB/132S/132SA	6	22000
11,1	2431	1,8	128,18	H123	100LB/112MS	4	30000
11,1	2449	2,8	86,43	H143	132S/132SA	6	55000
10,6	2543	1,2	134,06	H103	100LB/112MS	4	22000
10,3	2631	1,6	89,97	H123	112MB/132S/132SA	6	30000
10,0	2731	1,1	93,36	H103	112MB/132S/132SA	6	22000
10,0	2726	2,5	96,21	H143	132S/132SA	6	55000
9,9	2720	1,1	143,42	H103	100LB/112MS	4	22000
9,8	2746	1,6	144,79	H123	100LB/112MS	4	30000
9,3	2927	1,0	100,07	H103	112MB/132S/132SA	6	22000
9,3	2933	1,5	100,29	H123	112MB/132S/132SA	6	30000
9,2	2961	2,3	104,51	H143	132S/132SA	6	55000
9,1	2944	1,4	155,22	H123	100LB/112MS	4	30000
8,6	3169	1,3	108,34	H123	112MB/132S/132SA	6	30000
8,3	3284	2,1	115,92	H143	132S/132SA	6	55000
8,2	3277	1,3	172,80	H123	100LB/112MS	4	30000

3,00 kW

n2 [rpm]	M2 [Nm]	fs	i	Gear reducer	Motor Size	Pole	Fr2 [N]
7,8	3469	1,2	118,62	H123	112MB/132S/132SA	6	30000
7,5	3588	1,2	189,19	H123	100LB/112MS	4	30000
7,5	3640	1,9	128,47	H143	132S/132SA	6	55000
7,3	3749	1,1	128,18	H123	112MB/132S/132SA	6	30000
6,9	3954	1,7	139,55	H143	132S/132SA	6	55000
6,8	3934	1,1	207,43	H123	100LB/112MS	4	30000
6,4	4235	1,0	144,79	H123	112MB/132S/132SA	6	30000
6,2	4373	1,6	154,33	H143	132S/132SA	6	55000
5,2	5269	1,3	185,96	H143	132S/132SA	6	55000
4,7	5839	1,2	206,08	H143	132S/132SA	6	55000

4,00 kW

n2 [rpm]	M2 [Nm]	fs	i	Gear reducer	Motor Size	Pole	Fr2 [N]
1139,3	33	1,0	1,27	HR051	112M/112MA	4	1634
1087,5	34	2,3	1,33	HA61	112M/112MA	4	2029
1071,6	35	1,9	1,34	HR061	112M/112MA	4	2527
1014,5	37	1,4	1,42	HR051	112M/112MA	4	1681
677,6	55	1,9	2,13	HR061	112M/112MA	4	2882
580,0	64	1,2	2,50	HA61	112M/112MA	4	2502
563,9	66	1,6	2,57	HR061	112M/112MA	4	3031
502,3	75	2,6	1,93	HR081	132MA	6	3617
457,9	81	1,4	3,17	HR061	112M/112MA	4	3205
443,1	84	3,2	3,25	HR081	112M/112MA	4	3757
390,5	95	1,3	3,69	HR061	112M/112MA	4	3340
386,9	96	2,8	3,72	HR081	112M/112MA	4	3912
377,7	99	2,4	2,54	HR081	132MA	6	3937
360,0	103	1,2	4,00	HR061	112M/112MA	4	3409
360,0	103	2,6	4,00	HR081	112M/112MA	4	3995
308,6	120	2,3	4,67	HR081	112M/112MA	4	4000
301,9	123	1,1	4,77	HR061	112M/112MA	4	3558
295,4	127	2,1	3,25	HR081	132MA	6	4000
280,0	131	1,3	5,14	HA52	112M/112MA	4	2816
280,0	131	2,1	5,14	HA62	112M/112MA	4	4156
274,3	135	1,1	5,25	HR061	112M/112MA	4	3639
267,9	137	2,6	5,38	H062	112M/112MA	4	9838
260,0	143	2,0	5,54	HR081	112M/112MA	4	4000
257,9	145	1,8	3,72	HR081	132MA	6	4000
251,4	146	1,3	5,73	H052	112M/112MA	4	5546
242,6	151	2,6	5,93	H062	112M/112MA	4	10108
240,0	156	1,7	4,00	HR081	132MA	6	4000
236,7	157	1,9	6,08	HR081	112M/112MA	4	4000

4,00 kW

n2 [rpm]	M2 [Nm]	fs	i	Gear reducer	Motor Size	Pole	Fr2 [N]
231,4	158	1,1	6,22	HA52	112M/112MA	4	3000
231,4	158	1,7	6,22	HA62	112M/112MA	4	4428
231,1	160	3,4	6,23	HR101	112MA ⁽¹⁾	4	5000
227,4	165	3,2	4,22	HR101	132MA	6	5000
208,9	176	1,2	6,89	H052	112M/112MA	4	5759
205,7	182	1,5	4,67	HR081	132MA	6	4000
196,9	190	2,8	4,88	HR101	132MA	6	5000
194,8	188	2,1	7,39	H062	112M/112MA	4	10717
192,0	193	1,5	7,50	HR081	112M/112MA	4	4000
190,8	194	2,9	7,55	HR101	112M/112MA	4	5000
186,2	197	1,4	7,73	HA62	112M/112MA	4	4761
182,3	205	2,6	5,27	HR101	132MA	6	5000
178,6	207	1,7	5,38	H062	132MA	6	10950
178,1	208	2,4	5,39	H082	132MA	6	13822
173,3	216	1,3	5,54	HR081	132MA	6	4000
171,4	216	2,6	8,40	HR101	112M/112MA	4	5000
170,5	217	1,4	8,44	HR081	112M/112MA	4	4000
169,4	216	2,0	8,50	H062	112M/112MA	4	11111
168,9	217	1,1	8,53	H052	112M/112MA	4	5985
161,8	229	1,7	5,93	H062	132MA	6	11228
161,5	229	2,2	5,95	H082	132MA	6	14212
157,8	237	1,2	6,08	HR081	132MA	6	4000
154,1	243	2,2	6,23	HR101	132MA	6	5000
153,6	244	3,1	6,25	HR121	132MA	6	6000
153,4	239	1,8	9,39	H062	112M/112MA	4	11391
150,6	244	1,1	9,56	H052	112M/112MA	4	6095
149,3	246	1,4	9,64	HA62	112M/112MA	4	5125
129,9	285	1,4	7,39	H062	132MA	6	11844
129,8	285	2,0	7,39	H082	132MA	6	15095
128,0	292	1,0	7,50	HR081	132MA	6	4000
127,2	294	1,9	7,55	HR101	132MA	6	5000
124,7	300	2,8	7,70	HR121	132MA	6	6000
123,4	297	1,1	11,67	HA62	112M/112MA	4	5461
123,2	298	1,6	11,69	H062	112M/112MA	4	12000
119,7	309	1,9	8,02	H082	132MA	6	15430
114,3	327	1,7	8,40	HR101	132MA	6	5000
113,7	323	1,6	12,67	H062	112M/112MA	4	12000
112,9	328	1,3	8,50	H062	132MA	6	12000
108,5	341	1,9	8,85	H082	132MA	6	15840
102,3	362	1,2	9,39	H062	132MA	6	12000
97,6	376	1,3	14,75	H062	112M/112MA	4	12000
96,7	379	2,8	14,90	H082	112M/112MA	4	16340

⁽¹⁾ Available only with brake motor (TBS)

6.1 H/HA GEARED MOTORS (50Hz)

4,00 kW

n2 [rpm]	M2 [Nm]	fs	i	Gear reducer	Motor Size	Pole	Fr2 [N]
88,4	415	1,4	16,29	H062	112M/112MA	4	12000
87,2	425	1,9	11,01	H082	132MA	6	16758
86,7	423	2,6	16,62	H082	112M/112MA	4	16804
82,1	451	1,0	11,69	H062	132MA	6	12000
81,5	450	1,3	17,67	H062	112M/112MA	4	12000
77,7	472	2,3	18,53	H082	112M/112MA	4	17266
75,8	489	1,0	12,67	H062	132MA	6	12000
74,3	494	2,3	19,38	H082	112M/112MA	4	17459
71,1	521	1,9	13,50	H082	132MA	6	17621
71,0	516	1,2	20,28	H062	112M/112MA	4	12000
67,3	545	2,1	21,39	H082	112M/112MA	4	17876
64,4	575	1,9	14,90	H082	132MA	6	18000
63,2	581	2,0	22,80	H082	112M/112MA	4	18000
61,9	593	1,0	23,27	H062	112M/112MA	4	12000
57,8	641	1,7	16,62	H082	132MA	6	18000
54,1	677	1,7	26,60	H082	112M/112MA	4	18000
51,8	715	1,5	18,53	H082	132MA	6	18000
51,6	710	1,6	27,88	H082	112M/112MA	4	18000
49,5	748	1,5	19,38	H082	132MA	6	18000
46,2	793	1,7	31,15	H082	112M/112MA	4	18000
44,9	825	1,4	21,39	H082	132MA	6	18000
42,1	880	1,3	22,80	H082	132MA	6	18000
42,1	871	3,1	34,20	H102	112M/112MA	4	22000
41,9	875	1,6	34,38	H082	112M/112MA	4	18000
40,1	925	2,6	23,97	H102	132MA	6	22000
37,4	979	2,4	38,45	H102	112M/112MA	4	22000
37,2	986	1,4	38,70	H082	112M/112MA	4	18000
37,1	999	2,4	25,89	H102	132MA	6	22000
36,1	1026	1,1	26,60	H082	132MA	6	18000
34,9	1052	2,7	41,30	H102	112M/112MA	4	22000
34,4	1076	1,1	27,88	H082	132MA	6	18000
33,7	1089	1,3	42,75	H082	112M/112MA	4	18000
33,4	1108	2,2	28,73	H102	132MA	6	22000
31,4	1167	2,4	45,82	H102	112M/112MA	4	22000
31,2	1185	2,3	30,72	H102	132MA	6	22000
30,8	1202	1,1	31,15	H082	132MA	6	18000
29,9	1226	1,1	48,13	H082	112M/112MA	4	18000
28,1	1320	2,1	34,20	H102	132MA	6	22000
28,0	1312	2,1	51,52	H102	112M/112MA	4	22000
27,9	1326	1,0	34,38	H082	132MA	6	18000
26,6	1394	3,1	36,13	H122	132MA	6	30000
25,0	1484	1,6	38,45	H102	132MA	6	22000

4,00 kW

n2 [rpm]	M2 [Nm]	fs	i	Gear reducer	Motor Size	Pole	Fr2 [N]
23,2	1593	1,8	41,30	H102	132MA	6	22000
21,8	1701	2,5	44,10	H122	132MA	6	30000
21,4	1679	2,5	67,32	H123	112M/112MA	4	30000
21,0	1768	1,6	45,82	H102	132MA	6	22000
21,0	1729	2,5	45,77	H123	132MA	6	30000
20,7	1738	1,7	69,69	H103	112M/112MA	4	22000
19,5	1838	2,3	73,71	H123	112M/112MA	4	30000
18,6	1988	1,4	51,52	H102	132MA	6	22000
18,0	1990	1,5	79,82	H103	112M/112MA	4	22000
17,3	2096	1,4	55,47	H103	132MA	6	22000
17,3	2078	2,1	83,34	H123	112M/112MA	4	30000
17,2	2111	2,0	55,87	H123	132MA	6	30000
17,1	2099	1,4	84,16	H103	112M/112MA	4	22000
16,2	2237	3,1	59,22	H143	132MA	6	55000
16,0	2244	1,9	89,97	H123	112M/112MA	4	30000
15,4	2328	1,3	93,36	H103	112M/112MA	4	22000
15,2	2380	2,9	62,99	H143	132MA	6	55000
14,4	2495	1,2	100,07	H103	112M/112MA	4	22000
14,4	2501	1,7	100,29	H123	112M/112MA	4	30000
14,3	2543	1,7	67,32	H123	132MA	6	30000
13,8	2633	1,1	69,69	H103	132MA	6	22000
13,5	2696	2,5	71,35	H143	132MA	6	55000
13,3	2702	1,6	108,34	H123	112M/112MA	4	30000
13,0	2785	1,5	73,71	H123	132MA	6	30000
12,2	2984	1,0	79,82	H103	132MA	6	22000
12,1	2958	1,4	118,62	H123	112M/112MA	4	30000
12,1	2987	2,3	79,07	H143	132MA	6	55000
11,5	3148	1,4	83,34	H123	132MA	6	30000
11,2	3196	1,3	128,18	H123	112M/112MA	4	30000
11,1	3265	2,1	86,43	H143	132MA	6	55000
10,7	3399	1,3	89,97	H123	132MA	6	30000
10,0	3634	1,9	96,21	H143	132MA	6	55000
9,9	3610	1,2	144,79	H123	112M/112MA	4	30000
9,6	3789	1,1	100,29	H123	132MA	6	30000
9,3	3871	1,1	155,22	H123	112M/112MA	4	30000
9,2	3948	1,7	104,51	H143	132MA	6	55000
8,9	4093	1,0	108,34	H123	132MA	6	30000
8,3	4379	1,6	115,92	H143	132MA	6	55000
7,5	4853	1,4	128,47	H143	132MA	6	55000
6,9	5272	1,3	139,55	H143	132MA	6	55000
6,2	5830	1,2	154,33	H143	132MA	6	55000

4,80 kW

n2 [rpm]	M2 [Nm]	fs	i	Gear reducer	Size	Motor	Pole	Fr2 [N]
1072,5	41	1,9	1,33	HA61	112MB ⁽¹⁾		4	2038
1064,2	42	1,5	1,34	HR061	112MB ⁽¹⁾		4	2504
1007,5	44	1,2	1,42	HR051	112MB ⁽¹⁾		4	1640
672,9	66	1,6	2,13	HR061	112MB ⁽¹⁾		4	2843
562,6	79	3,0	2,54	HR081	112MB ⁽¹⁾		4	3469
556,1	80	1,3	2,57	HR061	112MB ⁽¹⁾		4	2990
451,6	98	1,1	3,17	HR061	112MB ⁽¹⁾		4	3151
440,0	101	2,6	3,25	HR081	112MB ⁽¹⁾		4	3729
387,8	115	1,1	3,69	HR061	112MB ⁽¹⁾		4	3269
384,2	116	2,3	3,72	HR081	112MB ⁽¹⁾		4	3879
357,5	124	1,0	4,00	HR061	112MB ⁽¹⁾		4	3332
357,5	124	2,2	4,00	HR081	112MB ⁽¹⁾		4	3960
306,4	145	1,9	4,67	HR081	112MB ⁽¹⁾		4	4000
278,1	158	1,1	5,14	HA52	112MB ⁽¹⁾		4	2822
278,1	158	1,7	5,14	HA62	112MB ⁽¹⁾		4	4166
271,5	164	3,2	5,27	HR101	112MB ⁽¹⁾		4	5000
266,0	165	2,2	5,38	H062	112MB ⁽¹⁾		4	9696
258,2	172	1,6	5,54	HR081	112MB ⁽¹⁾		4	4000
249,7	176	1,1	5,73	H052	112MB ⁽¹⁾		4	5358
240,9	183	2,2	5,93	H062	112MB ⁽¹⁾		4	9950
235,1	189	1,5	6,08	HR081	112MB ⁽¹⁾		4	4000
229,8	191	1,4	6,22	HA62	112MB ⁽¹⁾		4	4439
229,5	194	2,8	6,23	HR101	112MB ⁽¹⁾		4	5000
193,5	227	1,7	7,39	H062	112MB ⁽¹⁾		4	10516
190,7	233	1,3	7,50	HR081	112MB ⁽¹⁾		4	4000
189,5	235	2,4	7,55	HR101	112MB ⁽¹⁾		4	5000
184,9	238	1,2	7,73	HA62	112MB ⁽¹⁾		4	4772
170,2	261	2,1	8,40	HR101	112MB ⁽¹⁾		4	5000
169,3	263	1,1	8,44	HR081	112MB ⁽¹⁾		4	4000
168,2	262	1,7	8,50	H062	112MB ⁽¹⁾		4	10876
152,4	289	1,5	9,39	H062	112MB ⁽¹⁾		4	11130
148,3	297	1,1	9,64	HA62	112MB ⁽¹⁾		4	5137
122,4	360	1,3	11,69	H062	112MB ⁽¹⁾		4	11679
112,9	390	1,3	12,67	H062	112MB ⁽¹⁾		4	11874
105,9	415	2,4	13,50	H082	112MB ⁽¹⁾		4	15638
96,9	454	1,1	14,75	H062	112MB ⁽¹⁾		4	12000
96,0	458	2,4	14,90	H082	112MB ⁽¹⁾		4	16020
87,8	501	1,1	16,29	H062	112MB ⁽¹⁾		4	12000
86,1	511	2,1	16,62	H082	112MB ⁽¹⁾		4	16444
80,9	544	1,1	17,67	H062	112MB ⁽¹⁾		4	12000
77,2	570	1,9	18,53	H082	112MB ⁽¹⁾		4	16861
73,8	597	1,9	19,38	H082	112MB ⁽¹⁾		4	17034

⁽¹⁾ Available only with brake motor (TBS)

4,80 kW

n2 [rpm]	M2 [Nm]	fs	i	Gear reducer	Motor Size	Pole	Fr2 [N]
66,9	658	1,8	21,39	H082	112MB ⁽¹⁾	4	17404
62,7	702	1,6	22,80	H082	112MB ⁽¹⁾	4	17640
53,8	819	1,4	26,60	H082	112MB ⁽¹⁾	4	18000
51,3	858	1,3	27,88	H082	112MB ⁽¹⁾	4	18000
49,8	884	2,7	28,73	H102	112MB ⁽¹⁾	4	22000
46,5	945	2,9	30,72	H102	112MB ⁽¹⁾	4	22000
45,9	959	1,4	31,15	H082	112MB ⁽¹⁾	4	18000
41,8	1052	2,6	34,20	H102	112MB ⁽¹⁾	4	22000
41,6	1058	1,3	34,38	H082	112MB ⁽¹⁾	4	18000
37,2	1183	2,0	38,45	H102	112MB ⁽¹⁾	4	22000
36,9	1191	1,1	38,70	H082	112MB ⁽¹⁾	4	18000
34,6	1271	2,2	41,30	H102	112MB ⁽¹⁾	4	22000
33,5	1316	1,0	42,75	H082	112MB ⁽¹⁾	4	18000
31,2	1410	2,0	45,82	H102	112MB ⁽¹⁾	4	22000
27,8	1585	1,8	51,52	H102	112MB ⁽¹⁾	4	22000
21,2	2029	2,1	67,32	H123	112MB ⁽¹⁾	4	30000
20,5	2100	1,4	69,69	H103	112MB ⁽¹⁾	4	22000
19,4	2221	1,9	73,71	H123	112MB ⁽¹⁾	4	30000
17,9	2405	1,2	79,82	H103	112MB ⁽¹⁾	4	22000
17,2	2511	1,7	83,34	H123	112MB ⁽¹⁾	4	30000
17,0	2536	1,2	84,16	H103	112MB ⁽¹⁾	4	22000
15,9	2711	1,6	89,97	H123	112MB ⁽¹⁾	4	30000
15,3	2813	1,1	93,36	H103	112MB ⁽¹⁾	4	22000
14,3	3022	1,4	100,29	H123	112MB ⁽¹⁾	4	30000
13,2	3265	1,3	108,34	H123	112MB ⁽¹⁾	4	30000
12,1	3574	1,2	118,62	H123	112MB ⁽¹⁾	4	30000
11,2	3862	1,1	128,18	H123	112MB ⁽¹⁾	4	30000

5,50 kW

n2 [rpm]	M2 [Nm]	fs	i	Gear reducer	Motor Size	Pole	Fr2 [N]
750,9	68	2,9	1,93	HR081	132MS/132S	4	3162
740,0	70	1,9	1,30	HR081	132MB	6	3174
672,0	77	2,3	1,43	HR081	132MB	6	3267
574,4	89	2,7	2,54	HR081	132MS/132S	4	3423
497,1	104	1,9	1,93	HR081	132MB	6	3569
446,2	114	2,3	3,25	HR081	132MS/132S	4	3684
389,6	131	2,0	3,72	HR081	132MS/132S	4	3828
377,7	136	1,7	2,54	HR081	132MB	6	3859
362,5	141	1,9	4,00	HR081	132MS/132S	4	3906
310,7	164	1,7	4,67	HR081	132MS/132S	4	4000
297,4	171	3,1	4,88	HR101	132MS/132S	4	5000

⁽¹⁾ Available only with brake motor (TBS)

5,50 kW

n2 [rpm]	M2 [Nm]	fs	i	Gear reducer	Motor Size	Pole	Fr2 [N]
295,4	174	1,5	3,25	HR081	132MB	6	4000
293,3	175	2,9	3,27	HR101	132MB	6	5000
275,3	185	2,9	5,27	HR101	132MS/132S	4	5000
269,8	187	1,9	5,38	H062	132MS/132S	4	9522
269,1	187	2,7	5,39	H082	132MS/132S	4	12037
261,8	195	1,4	5,54	HR081	132MS/132S	4	4000
259,5	198	2,6	3,70	HR101	132MB	6	5000
257,9	200	1,3	3,72	HR081	132MB	6	4000
244,3	206	1,9	5,93	H062	132MS/132S	4	9761
243,9	207	2,4	5,95	H082	132MS/132S	4	12374
240,0	214	1,3	4,00	HR081	132MB	6	4000
238,4	214	1,4	6,08	HR081	132MS/132S	4	4000
232,7	219	2,5	6,23	HR101	132MS/132S	4	5000
227,4	226	2,3	4,22	HR101	132MB	6	5000
205,7	250	1,1	4,67	HR081	132MB	6	4000
200,0	257	2,9	4,80	HR121	132MB	6	6000
196,9	261	2,0	4,88	HR101	132MB	6	5000
196,2	257	1,5	7,39	H062	132MS/132S	4	10290
196,1	257	2,2	7,39	H082	132MS/132S	4	13137
193,3	264	1,1	7,50	HR081	132MS/132S	4	4000
192,2	265	2,1	7,55	HR101	132MS/132S	4	5000
188,3	271	3,1	7,70	HR121	132MS/132S	4	6000
184,1	280	2,7	5,21	HR121	132MB	6	6000
182,3	282	1,9	5,27	HR101	132MB	6	5000
180,8	279	2,1	8,02	H082	132MS/132S	4	13427
178,6	285	1,3	5,38	H062	132MB	6	10497
178,1	286	1,8	5,39	H082	132MB	6	13466
172,6	295	1,9	8,40	HR101	132MS/132S	4	5000
171,7	297	1,0	8,44	HR081	132MS/132S	4	4000
170,6	296	1,5	8,50	H062	132MS/132S	4	10621
163,8	308	2,1	8,85	H082	132MS/132S	4	13780
161,8	315	1,3	5,93	H062	132MB	6	10728
161,5	315	1,6	5,95	H082	132MB	6	13818
154,5	326	1,3	9,39	H062	132MS/132S	4	10852
154,1	334	1,6	6,23	HR101	132MB	6	5000
153,6	335	2,3	6,25	HR121	132MB	6	6000
131,7	383	2,1	11,01	H082	132MS/132S	4	14570
129,9	392	1,0	7,39	H062	132MB	6	11221
129,8	392	1,5	7,39	H082	132MB	6	14605
127,2	404	1,4	7,55	HR101	132MB	6	5000
124,7	413	2,1	7,70	HR121	132MB	6	6000
124,1	406	1,2	11,69	H062	132MS/132S	4	11343

5,50 kW

n2 [rpm]	M2 [Nm]	fs	i	Gear reducer	Motor Size	Pole	Fr2 [N]
119,7	426	1,4	8,02	H082	132MB	6	14899
114,5	440	1,1	12,67	H062	132MS/132S	4	11514
114,3	450	1,2	8,40	HR101	132MB	6	5000
108,5	470	1,4	8,85	H082	132MB	6	15254
107,4	469	2,2	13,50	H082	132MS/132S	4	15311
97,3	518	2,1	14,90	H082	132MS/132S	4	15665
89,0	566	1,0	16,29	H062	132MS/132S	4	11998
87,3	578	1,9	16,62	H082	132MS/132S	4	16054
87,2	584	1,4	11,01	H082	132MB	6	16029
78,3	644	1,7	18,53	H082	132MS/132S	4	16433
74,8	674	1,7	19,38	H082	132MS/132S	4	16589
71,1	716	1,4	13,50	H082	132MB	6	16728
67,8	744	1,6	21,39	H082	132MS/132S	4	16919
64,4	790	1,4	14,90	H082	132MB	6	17049
63,6	793	1,5	22,80	H082	132MS/132S	4	17128
60,5	834	2,9	23,97	H102	132S	4	22000
59,7	854	2,7	16,09	H102	132MB	6	22000
57,8	881	1,2	16,62	H082	132MB	6	17390
56,0	900	2,6	25,89	H102	132MS/132S	4	22000
54,5	925	1,2	26,60	H082	132MS/132S	4	17607
53,8	947	2,4	17,85	H102	132MB	6	22000
52,0	970	1,2	27,88	H082	132MS/132S	4	17744
51,8	983	1,1	18,53	H082	132MB	6	17710
50,5	999	2,4	28,73	H102	132MS/132S	4	22000
49,5	1028	1,1	19,38	H082	132MB	6	17836
48,4	1053	2,2	19,85	H102	132MB	6	22000
47,2	1068	2,6	30,72	H102	132MS/132S	4	22000
46,5	1083	1,3	31,15	H082	132MS/132S	4	18000
44,9	1135	1,0	21,39	H082	132MB	6	18000
44,8	1138	2,0	21,44	H102	132MB	6	22000
42,4	1189	2,3	34,20	H102	132MS/132S	4	22000
42,2	1195	1,1	34,38	H082	132MS/132S	4	18000
40,1	1272	1,9	23,97	H102	132MB	6	22000
40,1	1256	3,4	36,13	H122	132S ⁽¹⁾	4	30000
37,7	1337	1,8	38,45	H102	132MS/132S	4	22000
37,5	1346	1,0	38,70	H082	132MS/132S	4	18000
37,1	1374	1,7	25,89	H102	132MB	6	22000
35,1	1436	2,0	41,30	H102	132MS/132S	4	22000
34,9	1458	2,5	27,49	H122	132MB	6	30000
33,4	1524	1,6	28,73	H102	132MB	6	22000
32,9	1534	2,8	44,10	H122	132MS/132S	4	30000
32,1	1584	2,3	29,86	H122	132MB	6	30000

⁽¹⁾ Available only with brake motor (TBS)

5,50 kW

n2 [rpm]	M2 [Nm]	fs	i	Gear reducer	Motor Size	Pole	Fr2 [N]
31,7	1559	2,7	45,77	H123	132MS/132S	4	30000
31,6	1593	1,8	45,82	H102	132MS/132S	4	22000
31,2	1630	1,7	30,72	H102	132MB	6	22000
29,1	1751	2,4	33,00	H122	132MB	6	30000
28,1	1814	1,5	34,20	H102	132MB	6	22000
28,1	1791	1,6	51,52	H102	132MS/132S	4	22000
26,6	1917	2,2	36,13	H122	132MB	6	30000
26,1	1889	1,6	55,47	H103	132MS/132S	4	22000
26,0	1902	2,2	55,87	H123	132MS/132S	4	30000
25,0	2040	1,2	38,45	H102	132MB	6	22000
24,5	2016	3,4	59,22	H143	132S	4	55000
23,2	2191	1,3	41,30	H102	132MB	6	22000
23,0	2145	3,2	62,99	H143	132MS/132S	4	55000
21,8	2340	1,8	44,10	H122	132MB	6	30000
21,5	2292	1,9	67,32	H123	132MS/132S	4	30000
21,0	2431	1,2	45,82	H102	132MB	6	22000
21,0	2378	1,8	45,77	H123	132MB	6	30000
20,8	2373	1,3	69,69	H103	132MS/132S	4	22000
20,3	2430	2,8	71,35	H143	132MS/132S	4	55000
19,7	2510	1,7	73,71	H123	132MS/132S	4	30000
18,6	2733	1,0	51,52	H102	132MB	6	22000
18,3	2693	2,5	79,07	H143	132MS/132S	4	55000
18,2	2718	1,1	79,82	H103	132MS/132S	4	22000
17,9	2780	2,5	53,53	H143	132MB	6	55000
17,4	2838	1,5	83,34	H123	132MS/132S	4	30000
17,3	2882	1,0	55,47	H103	132MB	6	22000
17,2	2866	1,0	84,16	H103	132MS/132S	4	22000
17,2	2902	1,5	55,87	H123	132MB	6	30000
16,8	2943	2,3	86,43	H143	132MS/132S	4	55000
16,2	3076	2,2	59,22	H143	132MB	6	55000
16,1	3064	1,4	89,97	H123	132MS/132S	4	30000
15,2	3272	2,1	62,99	H143	132MB	6	55000
15,1	3276	2,1	96,21	H143	132MS/132S	4	55000
14,5	3415	1,3	100,29	H123	132MS/132S	4	30000
14,3	3497	1,2	67,32	H123	132MB	6	30000
13,9	3559	1,9	104,51	H143	132MS/132S	4	55000
13,5	3706	1,8	71,35	H143	132MB	6	55000
13,4	3689	1,2	108,34	H123	132MS/132S	4	30000
13,0	3829	1,1	73,71	H123	132MB	6	30000
12,5	3947	1,7	115,92	H143	132MS/132S	4	55000
12,2	4039	1,1	118,62	H123	132MS/132S	4	30000
12,1	4108	1,7	79,07	H143	132MB	6	55000

6.1 H/HA GEARED MOTORS (50Hz)

5,50 kW

n2 [rpm]	M2 [Nm]	fs	i	Gear reducer	Motor Size	Pole	Fr2 [N]
11,3	4374	1,6	128,47	H143	132MS/132S	4	55000
11,1	4490	1,5	86,43	H143	132MB	6	55000
10,4	4752	1,4	139,55	H143	132MS/132S	4	55000
10,0	4997	1,4	96,21	H143	132MB	6	55000
9,4	5255	1,3	154,33	H143	132MS/132S	4	55000
9,2	5429	1,3	104,51	H143	132MB	6	55000
8,3	6021	1,1	115,92	H143	132MB	6	55000
7,8	6332	1,1	185,96	H143	132MS/132S	4	55000
7,5	6673	1,0	128,47	H143	132MB	6	55000

7,50 kW

n2 [rpm]	M2 [Nm]	fs	i	Gear reducer	Motor Size	Pole	Fr2 [N]
1125,4	62	1,4	1,30	HR081	132MA/132M	4	2762
1022,0	68	1,7	1,43	HR081	132MA/132M	4	2842
750,9	93	2,1	1,93	HR081	132MA/132M	4	3110
570,5	122	2,0	2,54	HR081	132MA/132M	4	3362
477,3	147	2,6	2,03	HR101	160M	6	4564
446,2	156	1,7	3,25	HR081	132MA/132M	4	3596
443,1	157	3,3	3,27	HR101	132MA/132M	4	4669
391,9	177	2,9	3,70	HR101	132MA/132M	4	4842
390,9	180	2,6	2,48	HR101	160M	6	4843
389,6	178	1,5	3,72	HR081	132MA/132M	4	3728
362,5	192	1,4	4,00	HR081	132MA/132M	4	3798
343,4	202	2,6	4,22	HR101	132MA/132M	4	5000
310,7	224	1,2	4,67	HR081	132MA/132M	4	3950
308,6	227	3,1	3,14	HR121	160M	6	6000
302,1	230	3,2	4,80	HR121	132MA/132M	4	6000
297,4	234	2,3	4,88	HR101	132MA/132M	4	5000
296,4	237	2,2	3,27	HR101	160M	6	5000
278,1	250	3,0	5,21	HR121	132MA/132M	4	6000
275,3	252	2,1	5,27	HR101	132MA/132M	4	5000
271,0	259	2,8	3,58	HR121	160M	6	6000
269,8	255	1,4	5,38	H062	132MA/132M	4	9126
269,1	256	2,0	5,39	H082	132MA/132M	4	11725
262,2	268	1,9	3,70	HR101	160M	6	5000
261,8	265	1,1	5,54	HR081	132MA/132M	4	4000
244,3	281	1,4	5,93	H062	132MA/132M	4	9324
243,9	282	1,8	5,95	H082	132MA/132M	4	12030
240,0	289	1,0	6,08	HR081	132MA/132M	4	4000
235,6	298	2,4	4,12	HR121	160M	6	6000
232,7	299	1,8	6,23	HR101	132MA/132M	4	5000

7,50 kW

n2 [rpm]	M2 [Nm]	fs	i	Gear reducer	Motor Size	Pole	Fr2 [N]
232,0	299	2,6	6,25	HR121	132MA/132M	4	6000
229,7	305	1,7	4,22	HR101	160M	6	5000
202,1	347	2,1	4,80	HR121	160M	6	6000
199,0	353	1,5	4,88	HR101	160M	6	5000
196,2	350	1,1	7,39	H062	132MA/132M	4	9745
196,1	351	1,6	7,39	H082	132MA/132M	4	12709
192,2	362	1,5	7,55	HR101	132MA/132M	4	5000
188,3	369	2,3	7,70	HR121	132MA/132M	4	6000
186,0	377	2,0	5,21	HR121	160M	6	6000
184,2	381	1,4	5,27	HR101	160M	6	5000
180,8	380	1,5	8,02	H082	132MA/132M	4	12963
180,0	386	1,3	5,39	H082	160M	6	12958
172,6	402	1,4	8,40	HR101	132MA/132M	4	5000
170,6	403	1,1	8,50	H062	132MA/132M	4	9995
163,8	420	1,5	8,85	H082	132MA/132M	4	13268
163,1	426	1,2	5,95	H082	160M	6	13262
155,7	451	1,2	6,23	HR101	160M	6	5000
155,2	452	1,7	6,25	HR121	160M	6	6000
131,7	522	1,5	11,01	H082	132MA/132M	4	13933
131,2	529	1,1	7,39	H082	160M	6	13922
128,6	546	1,0	7,55	HR101	160M	6	5000
126,0	557	1,5	7,70	HR121	160M	6	6000
120,9	574	1,0	8,02	H082	160M	6	14162
109,6	634	1,0	8,85	H082	160M	6	14444
107,4	640	1,6	13,50	H082	132MA/132M	4	14530
97,3	706	1,5	14,90	H082	132MA/132M	4	14804
88,1	788	1,0	11,01	H082	160M	6	15032
87,5	794	2,7	11,09	H102	160M	6	22000
87,3	788	1,4	16,62	H082	132MA/132M	4	15093
81,2	847	2,7	17,85	H102	132MA/132M	4	22000
78,3	878	1,2	18,53	H082	132MA/132M	4	15362
74,8	919	1,3	19,38	H082	132MA/132M	4	15468
73,1	941	2,5	19,85	H102	132MA/132M	4	22000
72,8	954	2,3	13,32	H102	160M	6	22000
71,9	967	1,0	13,50	H082	160M	6	15514
67,8	1014	1,1	21,39	H082	132MA/132M	4	15682
67,6	1017	2,3	21,44	H102	132MA/132M	4	22000
65,1	1066	1,0	14,90	H082	160M	6	15715
63,6	1081	1,1	22,80	H082	132MA/132M	4	15809
60,5	1137	2,1	23,97	H102	132MA/132M	4	22000
60,3	1152	2,0	16,09	H102	160M	6	22000
56,0	1228	1,9	25,89	H102	132MA/132M	4	22000

7,50 kW

n2 [rpm]	M2 [Nm]	fs	i	Gear reducer	Motor Size	Pole	Fr2 [N]
54,3	1278	1,8	17,85	H102	160M	6	22000
52,7	1304	2,8	27,49	H122	132MA/132M	4	30000
50,5	1362	1,8	28,73	H102	132MA/132M	4	22000
50,2	1383	2,6	19,32	H122	160M	6	30000
48,9	1421	1,6	19,85	H102	160M	6	22000
48,6	1416	2,5	29,86	H122	132MA/132M	4	30000
47,2	1457	1,9	30,72	H102	132MA/132M	4	22000
47,2	1473	2,5	20,57	H122	160M	6	30000
45,2	1535	1,5	21,44	H102	160M	6	22000
43,9	1565	2,7	33,00	H122	132MA/132M	4	30000
43,1	1613	2,2	22,52	H122	160M	6	30000
42,4	1622	1,7	34,20	H102	132MA/132M	4	22000
40,5	1716	1,4	23,97	H102	160M	6	22000
40,1	1713	2,5	36,13	H122	132MA/132M	4	30000
39,6	1752	2,1	24,47	H122	160M	6	30000
37,7	1823	1,3	38,45	H102	132MA/132M	4	22000
37,5	1854	1,3	25,89	H102	160M	6	22000
35,3	1968	1,8	27,49	H122	160M	6	30000
35,1	1958	1,4	41,30	H102	132MA/132M	4	22000
33,8	2057	1,2	28,73	H102	160M	6	22000
32,9	2091	2,0	44,10	H122	132MA/132M	4	30000
32,5	2138	1,7	29,86	H122	160M	6	30000
31,7	2125	2,0	45,77	H123	132MA/132M	4	30000
31,6	2199	1,2	30,72	H102	160M	6	22000
31,6	2173	1,3	45,82	H102	132MA/132M	4	22000
30,1	2308	3,0	32,24	H142	160M	6	55000
29,4	2363	1,8	33,00	H122	160M	6	30000
28,4	2449	1,1	34,20	H102	160M	6	22000
28,1	2443	1,2	51,52	H102	132MA/132M	4	22000
27,1	2485	2,8	53,53	H143	132MA/132M	4	55000
26,8	2587	1,7	36,13	H122	160M	6	30000
26,1	2576	1,2	55,47	H103	132MA/132M	4	22000
26,0	2594	1,6	55,87	H123	132MA/132M	4	30000
25,0	2781	2,5	38,85	H142	160M	6	55000
24,5	2750	2,5	59,22	H143	132MA/132M	4	55000
23,0	2925	2,3	62,99	H143	132MA/132M	4	55000
22,5	3083	2,2	43,05	H142	160M	6	55000
22,0	3157	1,4	44,10	H122	160M	6	30000
21,5	3126	1,4	67,32	H123	132MA/132M	4	30000
21,2	3209	1,3	45,77	H123	160M	6	30000
20,3	3313	2,1	71,35	H143	132MA/132M	4	55000
20,1	3389	2,0	48,35	H143	160M	6	55000

6.1 H/HA GEARED MOTORS (50Hz)

7,50 kW

n2 [rpm]	M2 [Nm]	fs	i	Gear reducer	Motor Size	Pole	Fr2 [N]
19,7	3423	1,2	73,71	H123	132MA/132M	4	30000
18,3	3672	1,9	79,07	H143	132MA/132M	4	55000
18,1	3752	1,8	53,53	H143	160M	6	55000
17,4	3917	1,1	55,87	H123	160M	6	30000
17,4	3869	1,1	83,34	H123	132MA/132M	4	30000
16,8	4013	1,7	86,43	H143	132MA/132M	4	55000
16,4	4151	1,6	59,22	H143	160M	6	55000
16,1	4178	1,0	89,97	H123	132MA/132M	4	30000
15,4	4416	1,5	62,99	H143	160M	6	55000
15,1	4467	1,5	96,21	H143	132MA/132M	4	55000
13,9	4853	1,4	104,51	H143	132MA/132M	4	55000
13,6	5002	1,4	71,35	H143	160M	6	55000
12,5	5382	1,3	115,92	H143	132MA/132M	4	55000
12,3	5543	1,2	79,07	H143	160M	6	55000
11,3	5965	1,1	128,47	H143	132MA/132M	4	55000
11,2	6059	1,1	86,43	H143	160M	6	55000
10,4	6480	1,1	139,55	H143	132MA/132M	4	55000
10,1	6744	1,0	96,21	H143	160M	6	55000

9,20 kW

n2 [rpm]	M2 [Nm]	fs	i	Gear reducer	Motor Size	Pole	Fr2 [N]
1125,4	76	1,2	1,30	HR081	132MB	4	2732
1015,0	84	1,4	1,43	HR081	132MB	4	2815
756,1	113	1,7	1,93	HR081	132MB	4	3060
584,3	146	3,2	2,48	HR101	132MB	4	4257
570,5	149	1,6	2,54	HR081	132MB	4	3304
446,2	191	1,4	3,25	HR081	132MB	4	3521
443,1	192	2,7	3,27	HR101	132MB	4	4619
391,9	217	2,3	3,70	HR101	132MB	4	4786
389,6	219	1,2	3,72	HR081	132MB	4	3643
362,5	235	1,2	4,00	HR081	132MB	4	3707
352,1	242	3,0	4,12	HR121	132MB	4	6000
343,4	248	2,1	4,22	HR101	132MB	4	4970
302,1	282	2,6	4,80	HR121	132MB	4	6000
297,4	287	1,8	4,88	HR101	132MB	4	5000
278,1	306	2,4	5,21	HR121	132MB	4	6000
275,3	310	1,7	5,27	HR101	132MB	4	5000
269,8	313	1,2	5,38	H062	132MB	4	8789
269,1	313	1,6	5,39	H082	132MB	4	11460
244,3	345	1,1	5,93	H062	132MB	4	8952
243,9	346	1,5	5,95	H082	132MB	4	11737

6.1 H/HA GEARED MOTORS (50Hz)

9,20 kW

n2 [rpm]	M2 [Nm]	fs	i	Gear reducer	Size	Motor Pole	Fr2 [N]
232,7	366	1,5	6,23	HR101	132MB	4	5000
232,0	367	2,1	6,25	HR121	132MB	4	6000
196,1	430	1,3	7,39	H082	132MB	4	12346
192,2	443	1,3	7,55	HR101	132MB	4	5000
188,3	453	1,9	7,70	HR121	132MB	4	6000
180,8	467	1,2	8,02	H082	132MB	4	12568
172,6	494	1,1	8,40	HR101	132MB	4	5000
163,8	515	1,3	8,85	H082	132MB	4	12833
131,7	640	1,2	11,01	H082	132MB	4	13392
108,8	775	2,9	13,32	H102	132MB ⁽¹⁾	4	20334
107,4	785	1,3	13,50	H082	132MB	4	13866
97,3	866	1,2	14,90	H082	132MB	4	14071
90,1	936	2,5	16,09	H102	132MB	4	21219
87,3	967	1,1	16,62	H082	132MB	4	14276
81,2	1038	2,2	17,85	H102	132MB	4	21694
78,3	1078	1,0	18,53	H082	132MB	4	14451
74,8	1128	1,0	19,38	H082	132MB	4	14515
73,1	1155	2,0	19,85	H102	132MB	4	22000
67,6	1247	1,9	21,44	H102	132MB	4	22000
64,4	1310	2,8	22,52	H122	132MB	4	30000
60,5	1394	1,7	23,97	H102	132MB	4	22000
59,3	1423	2,5	24,47	H122	132MB	4	30000
56,0	1506	1,6	25,89	H102	132MB	4	22000
52,7	1599	2,3	27,49	H122	132MB	4	30000
50,5	1671	1,4	28,73	H102	132MB	4	22000
48,6	1737	2,1	29,86	H122	132MB	4	30000
47,2	1787	1,5	30,72	H102	132MB	4	22000
43,9	1920	2,2	33,00	H122	132MB	4	30000
42,4	1989	1,4	34,20	H102	132MB	4	22000
40,1	2102	2,0	36,13	H122	132MB	4	30000
37,7	2237	1,1	38,45	H102	132MB	4	22000
35,1	2402	1,2	41,30	H102	132MB	4	22000
32,9	2565	1,7	44,10	H122	132MB	4	30000
31,7	2607	1,6	45,77	H123	132MB	4	30000
31,6	2665	1,1	45,82	H102	132MB	4	22000
27,1	3049	2,2	53,53	H143	132MB	4	55000
26,0	3182	1,3	55,87	H123	132MB	4	30000
24,5	3373	2,0	59,22	H143	132MB	4	55000
23,0	3588	1,9	62,99	H143	132MB	4	55000
21,5	3835	1,1	67,32	H123	132MB	4	30000
20,3	4064	1,7	71,35	H143	132MB	4	55000
19,7	4198	1,0	73,71	H123	132MB	4	30000

⁽¹⁾ Available only with brake motor (TBS)

9,20 kW

n2 [rpm]	M2 [Nm]	fs	i	Gear reducer	Motor Size	Pole	Fr2 [N]
18,3	4504	1,5	79,07	H143	132MB	4	55000
16,8	4923	1,4	86,43	H143	132MB	4	55000
15,1	5480	1,2	96,21	H143	132MB	4	55000
13,9	5953	1,1	104,51	H143	132MB	4	55000
12,5	6603	1,0	115,92	H143	132MB	4	55000

11,00 kW

n2 [rpm]	M2 [Nm]	fs	i	Gear reducer	Motor Size	Pole	Fr2 [N]
1008,0	101	1,2	1,43	HR081	132MC ⁽¹⁾	4	2786
750,4	137	1,8	1,29	HR101	160L	6	3916
745,7	137	1,4	1,93	HR081	132MC ⁽¹⁾	4	3024
708,6	144	2,7	2,03	HR101	132MC/160MA/160S	4	3985
687,8	150	2,2	1,41	HR101	160L	6	4019
580,3	176	2,7	2,48	HR101	132MC/160MA/160S	4	4226
566,6	180	1,3	2,54	HR081	132MC ⁽¹⁾	4	3247
487,4	209	3,3	2,95	HR121	132MC/160S	4	5720
485,0	212	2,7	2,00	HR121	160L	6	5727
477,3	216	1,8	2,03	HR101	160L	6	4469
458,2	222	3,1	3,14	HR121	132MC/160MA/160S	4	5829
443,1	230	1,1	3,25	HR081	132MC ⁽¹⁾	4	3448
440,0	232	2,2	3,27	HR101	132MC/160MA/160S	4	4576
402,4	253	2,9	3,58	HR121	132MC/160MA/160S	4	6000
391,1	263	2,6	2,48	HR121	160L	6	6000
390,9	263	1,8	2,48	HR101	160L	6	4727
389,2	262	1,9	3,70	HR101	132MC/160MA/160S	4	4737
386,9	263	1,0	3,72	HR081	132MC ⁽¹⁾	4	3558
349,7	291	2,5	4,12	HR121	132MC/160MA/160S	4	6000
341,1	299	1,7	4,22	HR101	132MC/160MA/160S	4	4912
328,3	313	2,2	2,95	HR121	160L	6	6000
308,6	333	2,1	3,14	HR121	160L	6	6000
300,0	340	2,2	4,80	HR121	132MC/160MA/160S	4	6000
296,4	347	1,5	3,27	HR101	160L	6	5000
295,4	345	1,5	4,88	HR101	132MC/160MA/160S	4	5000
276,2	369	2,0	5,21	HR121	132MC/160MA/160S	4	6000
273,4	373	1,4	5,27	HR101	132MC/160MA/160S	4	5000
271,0	380	1,9	3,58	HR121	160L	6	6000
267,2	377	1,3	5,39	H082	132MC/160MA/160S	4	11197
262,2	393	1,3	3,70	HR101	160L	6	5000
242,2	416	1,2	5,95	H082	132MC/160MA/160S	4	11445
235,6	437	1,7	4,12	HR121	160L	6	6000
231,1	441	1,2	6,23	HR101	132MC/160MA/160S	4	5000

⁽¹⁾ Available only with brake motor (TBS)

11,00 kW

n2 [rpm]	M2 [Nm]	fs	i	Gear reducer	Motor Size	Pole	Fr2 [N]
230,4	442	1,7	6,25	HR121	132MC/160MA/160S	4	6000
229,7	448	1,2	4,22	HR101	160L	6	5000
202,1	509	1,5	4,80	HR121	160L	6	6000
199,0	517	1,0	4,88	HR101	160L	6	5000
194,7	518	1,1	7,39	H082	132MC/160MA/160S	4	11977
190,8	534	1,0	7,55	HR101	132MC/160MA/160S	4	5000
187,0	545	1,6	7,70	HR121	132MC/160MA/160S	4	6000
186,0	553	1,4	5,21	HR121	160L	6	6000
184,3	553	2,4	5,26	H102	160L	6	17463
179,5	562	1,0	8,02	H082	132MC/160MA/160S	4	12167
162,7	620	1,0	8,85	H082	132MC/160MA/160S	4	12387
155,2	663	1,2	6,25	HR121	160L	6	6000
152,6	667	2,2	6,36	H102	160L	6	18285
137,6	740	2,2	7,05	H102	160L	6	18733
130,8	771	1,0	11,01	H082	132MC/160MA/160S	4	12832
129,9	776	2,5	11,09	H102	132MC/160MA/160S	4	19008
126,0	817	1,0	7,70	HR121	160L	6	6000
117,2	869	2,1	8,27	H102	160L	6	19414
108,1	933	2,4	13,32	H102	132MC/160MA/160S	4	19788
106,7	945	1,1	13,50	H082	132MC/160MA/160S	4	13174
97,1	1049	1,9	9,99	H102	160L	6	20189
96,7	1043	1,0	14,90	H082	132MC/160MA/160S	4	13304
93,8	1086	2,7	10,35	H122	160L	6	30000
89,5	1127	2,0	16,09	H102	132MC/160MA/160S	4	20552
87,5	1164	1,9	11,09	H102	160L	6	20596
80,7	1250	1,8	17,85	H102	132MC/160MA/160S	4	20950
76,6	1330	2,4	12,66	H122	160L	6	30000
74,5	1353	2,7	19,32	H122	132MC/160MA/160S	4	30000
72,8	1399	1,6	13,32	H102	160L	6	21270
72,6	1390	1,7	19,85	H102	132MC/160MA/160S	4	21334
70,0	1456	2,3	13,86	H122	160L	6	30000
70,0	1441	2,5	20,57	H122	132MC/160MA/160S	4	30000
67,2	1502	1,5	21,44	H102	132MC/160MA/160S	4	21598
63,9	1577	2,3	22,52	H122	132MC/160MA/160S	4	30000
60,3	1690	1,4	16,09	H102	160L	6	21876
60,1	1679	1,4	23,97	H102	132MC/160MA/160S	4	21949
58,9	1714	2,1	24,47	H122	132MC/160MA/160S	4	30000
57,3	1777	2,0	16,92	H122	160L	6	30000
55,6	1813	1,3	25,89	H102	132MC/160MA/160S	4	22000
54,3	1874	1,2	17,85	H102	160L	6	22000
52,4	1925	1,9	27,49	H122	132MC/160MA/160S	4	30000
50,2	2029	1,8	19,32	H122	160L	6	30000

11,00 kW

n2 [rpm]	M2 [Nm]	fs	i	Gear reducer	Motor Size	Pole	Fr2 [N]
50,1	2012	1,2	28,73	H102	132MC/160MA/160S	4	22000
48,9	2084	1,1	19,85	H102	160L	6	22000
48,4	2105	2,7	20,04	H142	160L	6	51787
48,2	2091	1,7	29,86	H122	132MC/160MA/160S	4	30000
47,2	2160	1,7	20,57	H122	160L	6	30000
46,9	2151	1,3	30,72	H102	132MC/160MA/160S	4	22000
45,2	2252	1,0	21,44	H102	160L	6	22000
44,7	2258	3,0	32,24	H142	160MA/160S	4	52888
43,6	2311	1,8	33,00	H122	132MC/160MA/160S	4	30000
43,1	2365	1,5	22,52	H122	160L	6	30000
42,1	2395	1,1	34,20	H102	132MC/160MA/160S	4	22000
40,2	2536	2,3	24,15	H142	160L	6	54182
39,9	2530	1,7	36,13	H122	132MC/160MA/160S	4	30000
39,6	2569	1,4	24,47	H122	160L	6	30000
37,1	2721	2,5	38,85	H142	160MA/160S	4	55000
36,2	2810	2,1	26,76	H142	160L	6	55000
35,3	2887	1,3	27,49	H122	160L	6	30000
33,4	3015	2,3	43,05	H142	160MA/160S	4	55000
32,7	3088	1,4	44,10	H122	132MC/160MA/160S	4	30000
32,5	3136	1,2	29,86	H122	160L	6	30000
31,5	3139	1,4	45,77	H123	132MC/160MA/160S	4	30000
30,1	3386	2,0	32,24	H142	160L	6	55000
29,8	3315	2,1	48,35	H143	160MA/160S	4	55000
29,4	3465	1,2	33,00	H122	160L	6	30000
26,9	3671	1,9	53,53	H143	132MC/160MA/160S	4	55000
26,8	3794	1,1	36,13	H122	160L	6	30000
25,8	3831	1,1	55,87	H123	132MC/160MA/160S	4	30000
25,0	4080	1,7	38,85	H142	160L	6	55000
24,3	4061	1,7	59,22	H143	132MC/160MA/160S	4	55000
22,9	4320	1,6	62,99	H143	132MC/160MA/160S	4	55000
22,5	4521	1,5	43,05	H142	160L	6	55000
20,2	4893	1,4	71,35	H143	132MC/160MA/160S	4	55000
20,1	4971	1,4	48,35	H143	160L	6	55000
18,2	5422	1,3	79,07	H143	132MC/160MA/160S	4	55000
18,1	5504	1,2	53,53	H143	160L	6	55000
16,7	5927	1,2	86,43	H143	132MC/160MA/160S	4	55000
16,4	6089	1,1	59,22	H143	160L	6	55000
15,4	6477	1,1	62,99	H143	160L	6	55000
15,0	6597	1,0	96,21	H143	132MC/160MA/160S	4	55000

15,00 kW

n2 [rpm]	M2 [Nm]	fs	i	Gear reducer	Size	Motor Pole	Fr2 [N]
1141,0	122	1,3	1,29	HR101	160LA	4	3407
1045,9	133	1,6	1,41	HR101	160LA	4	3496
758,1	185	1,3	1,29	HR101	180L ⁽²⁾	6	3836
725,8	191	2,0	2,03	HR101	160LA	4	3886
694,9	202	1,6	1,41	HR101	180L ⁽²⁾	6	3932
691,8	203	1,5	1,42	HR121	180L ⁽²⁾	6	5079
594,8	234	2,3	2,48	HR121	160LA	4	5318
594,4	234	2,0	2,48	HR101	160LA	4	4110
542,5	259	1,9	1,81	HR121	180L ⁽²⁾	6	5464
499,2	278	2,4	2,95	HR121	160LA	4	5604
490,0	286	2,0	2,00	HR121	180L ⁽²⁾	6	5632
482,2	291	1,3	2,03	HR101	180L ⁽²⁾	6	4348
469,3	296	2,4	3,14	HR121	160LA	4	5707
450,7	308	1,7	3,27	HR101	160LA	4	4431
412,1	337	2,2	3,58	HR121	160LA	4	5929
398,6	349	1,5	3,70	HR101	160LA	4	4576
395,2	355	1,9	2,48	HR121	180L ⁽²⁾	6	5998
394,9	355	1,3	2,48	HR101	180L ⁽²⁾	6	4582
358,2	388	1,9	4,12	HR121	160LA	4	6000
349,3	398	1,3	4,22	HR101	160LA	4	4733
331,7	423	1,6	2,95	HR121	180L ⁽²⁾	6	6000
311,8	450	1,6	3,14	HR121	180L ⁽²⁾	6	6000
307,3	452	1,6	4,80	HR121	160LA	4	6000
302,6	459	1,2	4,88	HR101	160LA	4	4904
299,4	469	1,1	3,27	HR101	180L ⁽²⁾	6	4910
282,9	491	1,5	5,21	HR121	160LA	4	6000
280,3	491	2,1	5,26	H102	160LA	4	15172
280,1	496	1,1	5,27	HR101	160LA	4	4996
273,8	513	1,4	3,58	HR121	180L ⁽²⁾	6	6000
273,7	502	1,0	5,39	H082	160LA	4	10523
238,0	590	1,2	4,12	HR121	180L ⁽²⁾	6	6000
236,0	589	1,3	6,25	HR121	160LA	4	6000
232,1	593	2,0	6,36	H102	160LA	4	15880
209,2	657	1,9	7,05	H102	160LA	4	16266
204,2	687	1,1	4,80	HR121	180L ⁽²⁾	6	6000
191,6	725	1,2	7,70	HR121	160LA	4	6000
187,9	747	1,0	5,21	HR121	180L ⁽²⁾	6	6000
186,2	746	1,7	5,26	H102	180L ⁽²⁾	6	16664
178,3	771	2,1	8,27	H102	160LA	4	16850
154,2	901	1,6	6,36	H102	180L ⁽²⁾	6	17329
147,6	932	1,9	9,99	H102	160LA	4	17513
139,0	999	1,7	7,05	H102	180L ⁽²⁾	6	17679

(2) With TBS brake motor, please contact our Technical Sales Support

15,00 kW

n2 [rpm]	M2 [Nm]	fs	i	Gear reducer	Size	Motor Pole	Fr2 [N]
139,0	999	2,4	7,05	H122	180L ⁽²⁾	6	27584
133,1	1034	1,8	11,09	H102	160LA	4	17860
126,6	1097	2,4	7,74	H122	180L ⁽²⁾	6	28236
118,4	1173	1,5	8,27	H102	180L ⁽²⁾	6	18185
116,5	1181	2,5	12,66	H122	160LA	4	28851
115,6	1201	2,3	8,48	H122	180L ⁽²⁾	6	28865
110,7	1242	1,8	13,32	H102	160LA	4	18432
106,4	1293	2,4	13,86	H122	160LA	4	29482
98,1	1416	1,4	9,99	H102	180L ⁽²⁾	6	18716
94,7	1466	2,0	10,35	H122	180L ⁽²⁾	6	30000
91,7	1500	1,5	16,09	H102	160LA	4	18941
88,4	1571	1,4	11,09	H102	180L ⁽²⁾	6	18968
87,2	1578	2,1	16,92	H122	160LA	4	30000
82,6	1664	1,4	17,85	H102	160LA	4	19177
77,4	1795	1,8	12,66	H122	180L ⁽²⁾	6	30000
76,3	1801	2,0	19,32	H122	160LA	4	30000
74,3	1851	1,2	19,85	H102	160LA	4	19379
73,5	1889	1,2	13,32	H102	180L ⁽²⁾	6	19325
71,7	1918	1,9	20,57	H122	160LA	4	30000
70,7	1965	1,7	13,86	H122	180L ⁽²⁾	6	30000
68,8	1999	1,2	21,44	H102	160LA	4	19497
65,5	2100	1,7	22,52	H122	160LA	4	30000
62,2	2232	2,5	15,75	H142	180L ⁽²⁾	6	46783
61,5	2235	1,1	23,97	H102	160LA	4	19617
61,1	2252	2,6	24,15	H142	160LA	4	47054
60,9	2281	1,0	16,09	H102	180L ⁽²⁾	6	19540
60,3	2281	1,6	24,47	H122	160LA	4	30000
57,9	2398	1,4	16,92	H122	180L ⁽²⁾	6	30000
56,1	2474	2,3	17,45	H142	180L ⁽²⁾	6	47904
55,1	2495	2,3	26,76	H142	160LA	4	48180
53,7	2563	1,4	27,49	H122	160LA	4	30000
50,7	2738	1,3	19,32	H122	180L ⁽²⁾	6	30000
49,4	2784	1,3	29,86	H122	160LA	4	30000
48,9	2841	2,0	20,04	H142	180L ⁽²⁾	6	49389
47,6	2916	1,2	20,57	H122	180L ⁽²⁾	6	30000
45,7	3006	2,2	32,24	H142	160LA	4	50180
44,7	3077	1,4	33,00	H122	160LA	4	30000
43,5	3192	1,1	22,52	H122	180L ⁽²⁾	6	30000
40,8	3369	1,3	36,13	H122	160LA	4	30000
40,6	3423	1,7	24,15	H142	180L ⁽²⁾	6	51320
40,1	3468	1,0	24,47	H122	180L ⁽²⁾	6	30000
38,0	3622	1,9	38,85	H142	160LA	4	52091

(2) With TBS brake motor, please contact our Technical Sales Support

15,00 kW

n2 [rpm]	M2 [Nm]	fs	i	Gear reducer	Size	Motor Pole	Fr2 [N]
36,6	3793	1,5	26,76	H142	180L ⁽²⁾	6	52335
34,3	4014	1,7	43,05	H142	160LA	4	53089
33,4	4112	1,0	44,10	H122	160LA	4	30000
32,2	4179	1,0	45,77	H123	160LA	4	30000
30,5	4414	1,5	48,35	H143	160LA	4	54432
30,4	4570	1,5	32,24	H142	180L ⁽²⁾	6	54049
27,6	4887	1,4	53,53	H143	160LA	4	55000
25,2	5506	1,2	38,85	H142	180L ⁽²⁾	6	55000
24,9	5406	1,3	59,22	H143	160LA	4	55000
23,4	5751	1,2	62,99	H143	160LA	4	55000
22,8	6102	1,1	43,05	H142	180L ⁽²⁾	6	55000
20,7	6514	1,0	71,35	H143	160LA	4	55000
20,3	6709	1,0	48,35	H143	180L ⁽²⁾	6	55000

18,50 kW

n2 [rpm]	M2 [Nm]	fs	i	Gear reducer	Size	Motor Pole	Fr2 [N]
1137,2	151	1,1	1,29	HR101	180M ⁽²⁾	4	3371
1042,4	164	1,3	1,41	HR101	180M ⁽²⁾	4	3456
813,8	211	1,5	1,81	HR121	180M ⁽²⁾	4	4796
796,3	217	1,0	1,23	HR121	200LA ⁽²⁾	6	4825
735,0	233	1,6	2,00	HR121	180M ⁽²⁾	4	4944
723,3	237	1,6	2,03	HR101	180M ⁽²⁾	4	3828
691,8	250	1,2	1,42	HR121	200LA ⁽²⁾	6	5031
592,7	289	1,8	2,48	HR121	180M ⁽²⁾	4	5269
592,4	289	1,6	2,48	HR101	180M ⁽²⁾	4	4038
542,5	319	1,5	1,81	HR121	200LA ⁽²⁾	6	5403
497,5	344	2,0	2,95	HR121	180M ⁽²⁾	4	5544
490,0	353	1,6	2,00	HR121	200LA ⁽²⁾	6	5565
467,7	366	1,9	3,14	HR121	180M ⁽²⁾	4	5643
449,2	382	1,3	3,27	HR101	180M ⁽²⁾	4	4335
410,7	417	1,7	3,58	HR121	180M ⁽²⁾	4	5855
397,3	431	1,2	3,70	HR101	180M ⁽²⁾	4	4467
395,2	438	1,6	2,48	HR121	200LA ⁽²⁾	6	5915
357,0	480	1,5	4,12	HR121	180M ⁽²⁾	4	6000
348,2	492	1,1	4,22	HR101	180M ⁽²⁾	4	4608
331,7	522	1,3	2,95	HR121	200LA ⁽²⁾	6	6000
311,8	555	1,3	3,14	HR121	200LA ⁽²⁾	6	6000
306,3	560	1,3	4,80	HR121	180M ⁽²⁾	4	6000
281,9	608	1,2	5,21	HR121	180M ⁽²⁾	4	6000
279,3	607	1,7	5,26	H102	180M ⁽²⁾	4	14749
273,8	632	1,1	3,58	HR121	200LA ⁽²⁾	6	6000

⁽²⁾ With TBS brake motor, please contact our Technical Sales Support

18,50 kW

n2 [rpm]	M2 [Nm]	fs	i	Gear reducer	Size	Motor Pole	Fr2 [N]
235,2	729	1,1	6,25	HR121	180M ⁽²⁾	4	6000
231,3	733	1,6	6,36	H102	180M ⁽²⁾	4	15366
208,5	814	1,5	7,05	H102	180M ⁽²⁾	4	15695
185,8	922	2,3	5,27	H122	200LA ⁽²⁾	6	25022
177,7	955	1,7	8,27	H102	180M ⁽²⁾	4	16178
173,4	978	2,1	8,48	H122	180M ⁽²⁾	4	25485
169,7	1009	2,2	5,78	H122	200LA ⁽²⁾	6	25590
147,1	1153	1,5	9,99	H102	180M ⁽²⁾	4	16698
142,1	1194	1,9	10,35	H122	180M ⁽²⁾	4	26737
139,0	1232	1,9	7,05	H122	200LA ⁽²⁾	6	26833
132,6	1279	1,5	11,09	H102	180M ⁽²⁾	4	16954
126,6	1353	2,0	7,74	H122	200LA ⁽²⁾	6	27411
116,1	1461	2,0	12,66	H122	180M ⁽²⁾	4	27985
115,6	1482	1,9	8,48	H122	200LA ⁽²⁾	6	27962
110,3	1537	1,5	13,32	H102	180M ⁽²⁾	4	17339
106,0	1600	1,9	13,86	H122	180M ⁽²⁾	4	28531
94,7	1808	1,6	10,35	H122	200LA ⁽²⁾	6	29135
91,4	1857	1,2	16,09	H102	180M ⁽²⁾	4	17617
86,9	1952	1,7	16,92	H122	180M ⁽²⁾	4	29684
84,2	2014	2,4	17,45	H142	180M ⁽²⁾	4	42354
82,3	2060	1,1	17,85	H102	180M ⁽²⁾	4	17707
77,4	2213	1,4	12,66	H122	200LA ⁽²⁾	6	30000
76,1	2229	1,6	19,32	H122	180M ⁽²⁾	4	30000
75,0	2285	2,3	13,07	H142	200LA ⁽²⁾	6	43436
74,1	2290	1,0	19,85	H102	180M ⁽²⁾	4	17742
73,3	2313	2,4	20,04	H142	180M ⁽²⁾	4	43719
71,5	2374	1,5	20,57	H122	180M ⁽²⁾	4	30000
70,7	2423	1,4	13,86	H122	200LA ⁽²⁾	6	30000
65,3	2599	1,4	22,52	H122	180M ⁽²⁾	4	30000
62,2	2753	2,0	15,75	H142	200LA ⁽²⁾	6	45225
60,9	2786	2,1	24,15	H142	180M ⁽²⁾	4	45514
60,1	2823	1,3	24,47	H122	180M ⁽²⁾	4	30000
57,9	2958	1,2	16,92	H122	200LA ⁽²⁾	6	30000
56,1	3051	1,9	17,45	H142	200LA ⁽²⁾	6	46178
54,9	3088	1,9	26,76	H142	180M ⁽²⁾	4	46470
53,5	3172	1,1	27,49	H122	180M ⁽²⁾	4	30000
50,7	3377	1,1	19,32	H122	200LA ⁽²⁾	6	30000
49,2	3446	1,0	29,86	H122	180M ⁽²⁾	4	30000
48,9	3503	1,6	20,04	H142	200LA ⁽²⁾	6	47406
47,6	3596	1,0	20,57	H122	200LA ⁽²⁾	6	30000
45,6	3720	1,8	32,24	H142	180M ⁽²⁾	4	48110
44,5	3808	1,1	33,00	H122	180M ⁽²⁾	4	30000

⁽²⁾ With TBS brake motor, please contact our Technical Sales Support

18,50 kW

n2 [rpm]	M2 [Nm]	fs	i	Gear reducer	Size	Motor Pole	Fr2 [N]
40,7	4169	1,0	36,13	H122	180M ⁽²⁾	4	30000
40,6	4221	1,4	24,15	H142	200LA ⁽²⁾	6	48931
37,8	4482	1,5	38,85	H142	180M ⁽²⁾	4	49588
36,6	4678	1,2	26,76	H142	200LA ⁽²⁾	6	49688
34,1	4968	1,4	43,05	H142	180M ⁽²⁾	4	50309
30,4	5636	1,2	32,24	H142	200LA ⁽²⁾	6	50859
30,4	5462	1,3	48,35	H143	180M ⁽²⁾	4	51372
27,5	6047	1,1	53,53	H143	180M ⁽²⁾	4	51934
25,2	6791	1,0	38,85	H142	200LA ⁽²⁾	6	51701
24,8	6690	1,0	59,22	H143	180M ⁽²⁾	4	52385

22,00 kW

n2 [rpm]	M2 [Nm]	fs	i	Gear reducer	Size	Motor Pole	Fr2 [N]
1042,4	196	1,1	1,41	HR101	180L ⁽²⁾	4	3413
813,8	250	1,3	1,81	HR121	180L ⁽²⁾	4	4756
735,0	277	1,4	2,00	HR121	180L ⁽²⁾	4	4900
723,3	282	1,4	2,03	HR101	180L ⁽²⁾	4	3766
592,7	344	1,6	2,48	HR121	180L ⁽²⁾	4	5214
592,4	344	1,4	2,48	HR101	180L ⁽²⁾	4	3962
542,5	379	1,3	1,81	HR121	200LB ⁽²⁾	6	5343
497,5	410	1,7	2,95	HR121	180L ⁽²⁾	4	5478
490,0	420	1,4	2,00	HR121	200LB ⁽²⁾	6	5497
467,7	436	1,6	3,14	HR121	180L ⁽²⁾	4	5573
449,2	454	1,1	3,27	HR101	180L ⁽²⁾	4	4235
410,7	496	1,5	3,58	HR121	180L ⁽²⁾	4	5776
395,2	521	1,3	2,48	HR121	200LB ⁽²⁾	6	5831
357,0	571	1,3	4,12	HR121	180L ⁽²⁾	4	5998
331,7	621	1,1	2,95	HR121	200LB ⁽²⁾	6	6000
311,8	660	1,1	3,14	HR121	200LB ⁽²⁾	6	6000
306,3	665	1,1	4,80	HR121	180L ⁽²⁾	4	6000
281,9	723	1,0	5,21	HR121	180L ⁽²⁾	4	6000
279,3	722	1,5	5,26	H102	180L ⁽²⁾	4	14314
231,3	872	1,3	6,36	H102	180L ⁽²⁾	4	14840
208,5	967	1,3	7,05	H102	180L ⁽²⁾	4	15111
208,5	967	1,6	7,05	H122	180L ⁽²⁾	4	23829
189,9	1062	1,9	7,74	H122	180L ⁽²⁾	4	24370
185,8	1096	1,9	5,27	H122	200LB ⁽²⁾	6	24460
177,7	1135	1,4	8,27	H102	180L ⁽²⁾	4	15493
173,4	1163	1,8	8,48	H122	180L ⁽²⁾	4	24889
169,7	1200	1,8	5,78	H122	200LB ⁽²⁾	6	24975
154,2	1321	2,4	6,36	H142	200LB ⁽²⁾	6	35673

⁽²⁾ With TBS brake motor, please contact our Technical Sales Support

22,00 kW

n2 [rpm]	M2 [Nm]	fs	i	Gear reducer	Size	Motor Pole	Fr2 [N]
147,1	1371	1,3	9,99	H102	180L ⁽²⁾	4	15871
142,1	1420	1,6	10,35	H122	180L ⁽²⁾	4	26010
139,1	1464	2,3	7,04	H142	200LB ⁽²⁾	6	36612
139,0	1465	1,6	7,05	H122	200LB ⁽²⁾	6	26082
132,6	1521	1,2	11,09	H102	180L ⁽²⁾	4	16037
126,6	1609	1,7	7,74	H122	200LB ⁽²⁾	6	26587
125,0	1630	2,3	7,84	H142	200LB ⁽²⁾	6	37596
116,1	1737	1,7	12,66	H122	180L ⁽²⁾	4	27094
115,6	1762	1,6	8,48	H122	200LB ⁽²⁾	6	27059
110,3	1828	1,2	13,32	H102	180L ⁽²⁾	4	16237
106,0	1902	1,6	13,86	H122	180L ⁽²⁾	4	27556
103,7	1964	2,4	9,45	H142	200LB ⁽²⁾	6	39291
94,7	2151	1,3	10,35	H122	200LB ⁽²⁾	6	28033
93,6	2177	2,3	10,47	H142	200LB ⁽²⁾	6	40213
93,3	2161	2,2	15,75	H142	180L ⁽²⁾	4	40301
91,4	2208	1,0	16,09	H102	180L ⁽²⁾	4	16286
86,9	2322	1,4	16,92	H122	180L ⁽²⁾	4	28494
84,2	2395	2,0	17,45	H142	180L ⁽²⁾	4	41214
77,4	2632	1,2	12,66	H122	200LB ⁽²⁾	6	28893
76,1	2651	1,4	19,32	H122	180L ⁽²⁾	4	29043
75,0	2717	1,9	13,07	H142	200LB ⁽²⁾	6	42143
73,3	2750	2,0	20,04	H142	180L ⁽²⁾	4	42410
71,5	2823	1,3	20,57	H122	180L ⁽²⁾	4	29276
70,7	2882	1,2	13,86	H122	200LB ⁽²⁾	6	29223
65,3	3090	1,2	22,52	H122	180L ⁽²⁾	4	29579
62,2	3274	1,7	15,75	H142	200LB ⁽²⁾	6	43667
60,9	3314	1,7	24,15	H142	180L ⁽²⁾	4	43937
60,1	3357	1,1	24,47	H122	180L ⁽²⁾	4	29815
56,1	3628	1,6	17,45	H142	200LB ⁽²⁾	6	44451
54,9	3672	1,6	26,76	H142	180L ⁽²⁾	4	44722
48,9	4166	1,4	20,04	H142	200LB ⁽²⁾	6	45423
45,6	4424	1,5	32,24	H142	180L ⁽²⁾	4	46004
40,6	5020	1,2	24,15	H142	200LB ⁽²⁾	6	46542
37,8	5331	1,3	38,85	H142	180L ⁽²⁾	4	47051
36,6	5563	1,0	26,76	H142	200LB ⁽²⁾	6	47040
34,1	5907	1,2	43,05	H142	180L ⁽²⁾	4	47498
30,4	6702	1,0	32,24	H142	200LB ⁽²⁾	6	47669
30,4	6495	1,1	48,35	H143	180L ⁽²⁾	4	48280

⁽²⁾ With TBS brake motor, please contact our Technical Sales Support

30,00 kW

n2 [rpm]	M2 [Nm]	fs	i	Gear reducer	Size	Motor Pole	Fr2 [N]
737,5	377	1,0	2,00	HR121	200L ⁽²⁾	4	4794
594,8	467	1,1	2,48	HR121	200L ⁽²⁾	4	5083
499,2	557	1,2	2,95	HR121	200L ⁽²⁾	4	5324
469,3	592	1,2	3,14	HR121	200L ⁽²⁾	4	5409
412,1	674	1,1	3,58	HR121	200L ⁽²⁾	4	5589
279,6	984	1,4	5,27	H122	200L ⁽²⁾	4	21290
255,4	1077	1,3	5,78	H122	200L ⁽²⁾	4	21732
209,4	1313	1,7	7,04	H142	200L ⁽²⁾	4	31889
209,3	1314	1,2	7,05	H122	200L ⁽²⁾	4	22681
190,5	1444	1,4	7,74	H122	200L ⁽²⁾	4	23110
188,1	1462	2,0	7,84	H142	200L ⁽²⁾	4	32737
174,0	1581	1,3	8,48	H122	200L ⁽²⁾	4	23512
156,1	1762	1,8	9,45	H142	200L ⁽²⁾	4	34195
142,6	1929	1,2	10,35	H122	200L ⁽²⁾	4	24334
140,8	1953	1,7	10,47	H142	200L ⁽²⁾	4	34986
116,5	2361	1,3	12,66	H122	200L ⁽²⁾	4	25049
112,8	2437	1,8	13,07	H142	200L ⁽²⁾	4	36635
106,4	2585	1,2	13,86	H122	200L ⁽²⁾	4	25319
93,7	2937	1,6	15,75	H142	200L ⁽²⁾	4	37927
87,2	3155	1,0	16,92	H122	200L ⁽²⁾	4	25769
84,5	3255	1,5	17,45	H142	200L ⁽²⁾	4	38588
76,3	3603	1,0	19,32	H122	200L ⁽²⁾	4	25936
73,6	3737	1,5	20,04	H142	200L ⁽²⁾	4	39400
61,1	4503	1,3	24,15	H142	200L ⁽²⁾	4	40318
55,1	4991	1,2	26,76	H142	200L ⁽²⁾	4	40715
45,7	6012	1,1	32,24	H142	200L ⁽²⁾	4	41186

37,00 kW

n2 [rpm]	M2 [Nm]	fs	i	Gear reducer	Size	Motor Pole	Fr2 [N]
281,5	1205	1,6	5,27	H142	225S ⁽²⁾	4	28881
233,7	1452	1,4	6,36	H142	225S ⁽²⁾	4	30204
210,8	1609	1,4	7,04	H142	225S ⁽²⁾	4	30925
189,3	1792	1,6	7,84	H142	225S ⁽²⁾	4	31670
157,1	2159	1,4	9,45	H142	225S ⁽²⁾	4	32921
141,8	2392	1,3	10,47	H142	225S ⁽²⁾	4	33580
113,6	2986	1,4	13,07	H142	225S ⁽²⁾	4	34896
94,3	3598	1,3	15,75	H142	225S ⁽²⁾	4	35846
85,1	3987	1,2	17,45	H142	225S ⁽²⁾	4	36289
74,1	4578	1,2	20,04	H142	225S ⁽²⁾	4	36771
61,5	5517	1,0	24,15	H142	225S ⁽²⁾	4	37167

⁽²⁾ With TBS brake motor, please contact our Technical Sales Support

45,00 kW

n2 [rpm]	M2 [Nm]	fs	i	Gear reducer	Size	Motor Pole	Fr2 [N]
281,5	1465	1,3	5,27	H142	225M ⁽²⁾	4	28102
233,7	1766	1,2	6,36	H142	225M ⁽²⁾	4	29265
210,8	1957	1,1	7,04	H142	225M ⁽²⁾	4	29884
189,3	2179	1,3	7,84	H142	225M ⁽²⁾	4	30511
157,1	2625	1,2	9,45	H142	225M ⁽²⁾	4	31525
141,8	2910	1,1	10,47	H142	225M ⁽²⁾	4	32033
113,6	3631	1,2	13,07	H142	225M ⁽²⁾	4	32964
94,3	4376	1,1	15,75	H142	225M ⁽²⁾	4	33519

⁽²⁾ With TBS brake motor, please contact our Technical Sales Support

IHA32

Mn ₂ [Nm]	i	Pn ₁ [kW]	n ₂ [rpm]	Fr1 [N]	Fr2 [N]
58	5,38	2,06	325,3	330	1018
58	6,52	1,70	268,5	409	1085
54	8,11	1,27	215,8	373	1167
65	10,94	1,13	160,0	441	1289
58	13,25	0,84	132,1	363	1374
58	16,49	0,67	106,1	398	1478
65	20,26	0,61	86,4	453	1583
61	24,55	0,47	71,3	386	1688
68	30,55	0,42	57,3	374	1816
77	35,44	0,41	49,4	480	1908
77	44,10	0,33	39,7	398	2000
68	48,75	0,27	35,9	398	2000
81	60,67	0,25	28,9	472	2000

IHA33

Mn ₂ [Nm]	i	Pn ₁ [kW]	n ₂ [rpm]	Fr1 [N]	Fr2 [N]
84	51,32	0,32	34,1	472	2000
85	59,65	0,28	29,3	472	2000
87	72,27	0,23	24,2	472	2000
84	89,94	0,18	19,5	472	2000
85	110,51	0,15	15,8	472	2000
88	133,88	0,13	13,1	472	2000
82	166,61	0,10	10,5	472	2000
85	193,30	0,09	9,1	472	2000
79	240,55	0,06	7,3	472	2000
92	279,07	0,06	6,3	472	2000
76	347,29	0,04	5,0	472	2000

IHA41

Mn ₂ [Nm]	i	Pn ₁ [kW]	n ₂ [rpm]	Fr1 [N]	Fr2 [N]
21	1,45	2,74	1208,3	330	475
21	2,94	1,35	594,3	330	602
26	4,75	1,03	368,4	330	706
26	5,45	0,90	320,8	330	739
21	7,88	0,50	222,2	330	835
17	10,83	0,30	161,5	330	929

IHA42

Mn_2 [Nm]	i	Pn_1 [kW]	n2 [rpm]	Fr1 [N]	Fr2 [N]
101	5,38	3,58	325,3	330	2143
101	6,52	2,96	268,5	409	2284
94	8,11	2,21	215,8	369	2457
108	10,94	1,88	160,0	424	2714
101	13,25	1,46	132,1	381	2894
101	16,49	1,17	106,1	398	3112
108	20,26	1,02	86,4	432	3334
112	24,55	0,87	71,3	422	3554
120	30,55	0,75	57,3	359	3823
128	35,44	0,69	49,4	457	4017
120	44,10	0,52	39,7	371	4300
111	48,75	0,43	35,9	416	4300
120	60,67	0,38	28,9	428	4300

IHA43

Mn_2 [Nm]	i	Pn_1 [kW]	n2 [rpm]	Fr1 [N]	Fr2 [N]
129	51,32	0,49	34,1	427	4300
127	59,65	0,42	29,3	426	4300
127	72,27	0,34	24,2	409	4300
128	89,94	0,28	19,5	398	4300
127	110,51	0,22	15,8	403	4300
125	133,88	0,18	13,1	409	4300
128	166,61	0,15	10,5	398	4300
127	193,30	0,13	9,1	427	4300
132	240,55	0,11	7,3	398	4300
122	279,07	0,09	6,3	427	4300
133	347,29	0,07	5,0	398	4300

IHA51

Mn_2 [Nm]	i	Pn_1 [kW]	n2 [rpm]	Fr1 [N]	Fr2 [N]
34	1,45	4,43	1208,3	330	1309
34	2,94	2,18	594,3	330	1658
43	4,75	1,71	368,4	330	1945
43	5,45	1,49	320,8	330	2036
34	7,88	0,82	222,2	330	2302
21	10,83	0,37	161,5	330	2560

IHA52

Mn ₂ [Nm]	i	Pn ₁ [kW]	n ₂ [rpm]	Fr1 [N]	Fr2 [N]
173	5,14	6,42	340,3	550	2638
173	6,22	5,31	281,2	682	2811
173	7,73	4,27	226,3	664	3023
216	9,64	4,28	181,5	827	3253
202	11,67	3,30	150,0	636	3467
202	14,50	2,66	120,7	664	3727
216	16,91	2,44	103,5	758	3924
208	20,46	1,94	85,5	659	4181
202	25,43	1,52	68,8	641	4495
216	29,89	1,38	58,5	752	4744
256	36,17	1,35	48,4	682	5055
238	44,95	1,01	38,9	620	5435
256	49,78	0,98	35,2	798	5623
246	61,87	0,76	28,3	642	6000

IHA53

Mn ₂ [Nm]	i	Pn ₁ [kW]	n ₂ [rpm]	Fr1 [N]	Fr2 [N]
256	49,80	1,00	35,1	330	5624
256	60,25	0,83	29,1	409	5992
254	74,88	0,66	23,4	398	6000
254	88,02	0,56	19,9	421	6000
256	111,61	0,45	15,7	390	6000
258	138,71	0,36	12,6	398	6000
258	163,05	0,31	10,7	421	6000
252	200,27	0,25	8,7	403	6000
256	235,41	0,21	7,4	421	6000
248	284,81	0,17	6,1	409	6000
252	353,98	0,14	4,9	398	6000

IHA61

Mn ₂ [Nm]	i	Pn ₁ [kW]	n ₂ [rpm]	Fr1 [N]	Fr2 [N]
77	1,33	10,91	1312,5	550	1906
77	2,50	5,82	700,0	550	2350
94	4,38	4,05	399,1	550	2834
77	7,75	1,88	225,8	550	3426
60	10,67	1,06	164,1	550	3811

IHA62

Mn ₂ [Nm]	i	Pn ₁ [kW]	n ₂ [rpm]	Fr1 [N]	Fr2 [N]
274	5,14	10,17	340,3	550	3894
274	6,22	8,41	281,2	682	4150
274	7,73	6,76	226,3	664	4462
332	9,64	6,57	181,5	801	4802
318	11,67	5,20	150,0	652	5117
302	14,50	3,98	120,7	634	5502
360	16,91	4,06	103,5	842	5791
332	20,46	3,10	85,5	627	6171
310	25,43	2,33	68,8	621	6635
324	29,89	2,07	58,5	734	7002
400	36,17	2,11	48,4	712	7461
376	44,95	1,60	38,9	621	8000
316	49,78	1,21	35,2	626	8000
376	61,87	1,16	28,3	789	8000

IHA63

Mn ₂ [Nm]	i	Pn ₁ [kW]	n ₂ [rpm]	Fr1 [N]	Fr2 [N]
408	49,80	1,60	35,1	330	8000
408	60,25	1,32	29,1	409	8000
410	74,88	1,07	23,4	398	8000
408	88,02	0,90	19,9	421	8000
408	111,61	0,71	15,7	390	8000
410	138,71	0,58	12,6	398	8000
410	163,05	0,49	10,7	421	8000
406	200,27	0,40	8,7	403	8000
412	235,41	0,34	7,4	421	8000
404	284,81	0,28	6,1	409	8000
406	353,98	0,22	4,9	398	8000

IH032

Mn ₂ [Nm]	i	Pn ₁ [kW]	n ₂ [rpm]	Fr1 [N]	Fr2 [N]
69	4,70	2,80	372,7	742	2769
76	6,23	2,33	280,9	852	3037
90	7,76	2,21	225,4	877	3151
94	8,87	2,02	197,4	924	3300
101	10,14	1,90	172,5	952	3412
105	11,76	1,70	148,8	1001	3605
123	13,72	1,71	127,5	999	3625
123	14,66	1,60	119,4	1024	3743

IH032

Mn_2 [Nm]	i	Pn_1 [kW]	n_2 [rpm]	Fr_1 [N]	Fr_2 [N]
137	16,77	1,56	104,4	1033	3795
145	18,20	1,52	96,2	1044	3854
145	19,90	1,39	88,0	1075	4029
145	22,68	1,22	77,2	1115	4296
145	23,83	1,16	73,4	1129	4400
145	26,39	1,05	66,3	1156	4620
146	29,70	0,94	58,9	1184	4884
171	32,89	0,99	53,2	1205	5120
171	37,92	0,86	46,1	1231	5464
171	41,40	0,79	42,3	1246	5500
171	47,25	0,69	37,0	1265	5500

IH033

Mn_2 [Nm]	i	Pn_1 [kW]	n_2 [rpm]	Fr_1 [N]	Fr_2 [N]
170	53,59	0,62	32,7	1282	5500
172	66,78	0,50	26,2	1306	5500
172	74,84	0,45	23,4	1316	5500
169	99,27	0,33	17,6	1338	5500
172	108,05	0,31	16,2	1343	5500
169	123,71	0,27	14,2	1351	5500
173	143,33	0,24	12,2	1358	5500
166	178,61	0,18	9,8	1367	5500
173	197,17	0,17	8,9	1371	5500
175	245,70	0,14	7,1	1377	5500

IH042

Mn_2 [Nm]	i	Pn_1 [kW]	n_2 [rpm]	Fr_1 [N]	Fr_2 [N]
116	5,46	4,05	320,4	494	3589
116	7,19	3,08	243,5	718	4052
152	8,91	3,26	196,3	676	4056
173	10,31	3,20	169,7	686	4106
181	11,80	2,93	148,3	752	4303
181	13,57	2,55	128,9	841	4601
181	15,96	2,16	109,7	929	4965
181	19,00	1,82	92,1	1009	5379
181	21,00	1,65	83,3	1049	5627
188	23,15	1,55	75,6	1070	5799
188	26,04	1,38	67,2	1110	6112
202	27,50	1,40	63,6	1104	6106

IH042

Mn ₂ [Nm]	i	Pn ₁ [kW]	n ₂ [rpm]	Fr1 [N]	Fr2 [N]
238	30,45	1,49	57,5	1135	6393
238	34,10	1,33	51,3	1166	6600
238	37,76	1,20	46,3	1192	6600
238	43,75	1,04	40,0	1224	6600
238	47,53	0,96	36,8	1240	6600
238	54,25	0,84	32,3	1264	6600

IH043

Mn ₂ [Nm]	i	Pn ₁ [kW]	n ₂ [rpm]	Fr1 [N]	Fr2 [N]
256	61,83	0,81	28,3	1274	6600
256	76,67	0,65	22,8	1304	6600
256	87,05	0,57	20,1	1319	6600
256	114,55	0,44	15,3	1345	6600
256	125,69	0,40	13,9	1352	6600
256	142,04	0,35	12,3	1361	6600
256	165,38	0,30	10,6	1371	6600
256	205,07	0,24	8,5	1382	6600
256	227,50	0,22	7,7	1386	6600
256	282,10	0,18	6,2	1395	6600

IH052

Mn ₂ [Nm]	i	Pn ₁ [kW]	n ₂ [rpm]	Fr1 [N]	Fr2 [N]
188	5,73	6,27	305,6	328	4443
208	6,89	5,76	253,8	406	4642
241	8,53	5,40	205,2	458	4802
266	9,56	5,31	183,0	486	4884
280	11,51	4,64	152,0	599	5218
310	14,24	4,16	122,9	686	5530
324	16,59	3,73	105,5	759	5835
332	18,00	3,52	97,2	796	6011
332	19,97	3,17	87,6	855	6325
338	21,67	2,98	80,8	887	6515
338	24,71	2,61	70,8	950	6939
354	26,18	2,58	66,8	957	7006
354	28,44	2,38	61,5	992	7288
418	31,52	2,53	55,5	1032	7649
418	33,00	2,42	53,0	1048	7815
418	38,98	2,05	44,9	1102	8000
418	45,36	1,76	38,6	1144	8000

IH052

Mn ₂ [Nm]	i	Pn ₁ [kW]	n ₂ [rpm]	Fr1 [N]	Fr2 [N]
418	49,13	1,62	35,6	1163	8000
418	56,11	1,42	31,2	1192	8000

IH053

Mn ₂ [Nm]	i	Pn ₁ [kW]	n ₂ [rpm]	Fr1 [N]	Fr2 [N]
428	58,81	1,42	29,8	1198	8000
426	72,75	1,14	24,1	1236	8000
426	90,51	0,92	19,3	1268	8000
428	108,95	0,77	16,1	1290	8000
428	134,76	0,62	13,0	1311	8000
430	157,29	0,53	11,1	1323	8000
426	194,56	0,43	9,0	1338	8000
426	216,38	0,38	8,1	1344	8000
424	267,65	0,31	6,5	1354	8000

IH062

Mn ₂ [Nm]	i	Pn ₁ [kW]	n ₂ [rpm]	Fr1 [N]	Fr2 [N]
324	5,38	11,50	325,6	972	7181
342	5,93	11,00	294,9	979	7240
364	7,39	9,40	236,8	1346	8018
432	8,50	9,70	205,9	1423	8270
434	9,39	8,83	186,5	1557	8658
470	11,69	7,68	149,7	1724	9291
505	12,67	7,61	138,2	1731	9366
505	14,75	6,54	118,6	1888	10053
575	16,29	6,74	107,5	1854	9972
600	17,67	6,48	99,1	1897	10202
610	20,28	5,74	86,3	1999	10787
610	23,27	5,00	75,2	2108	11512
610	25,70	4,53	68,1	2177	12000
576	29,33	3,75	59,7	2293	12000
725	32,00	4,32	54,7	2308	12000
680	36,99	3,51	47,3	2407	12000
725	40,33	3,43	43,4	2418	12000
725	46,06	3,00	38,0	2471	12000

IH063

Mn ₂ [Nm]	i	Pn ₁ [kW]	n ₂ [rpm]	Fr1 [N]	Fr2 [N]
725	49,45	2,86	35,4	2496	12000
725	54,61	2,59	32,0	2529	12000
725	68,00	2,08	25,7	2590	12000
720	85,82	1,64	20,4	2643	12000
725	94,76	1,49	18,5	2661	12000
720	118,00	1,19	14,8	2697	12000
725	135,40	1,04	12,9	2715	12000
725	149,51	0,95	11,7	2727	12000
725	170,67	0,83	10,2	2742	12000
720	186,18	0,75	9,4	2750	12000
730	215,21	0,66	8,1	2762	12000
720	234,67	0,60	7,5	2769	12000
715	268,00	0,52	6,5	2778	12000

IH082

Mn ₂ [Nm]	i	Pn ₁ [kW]	n ₂ [rpm]	Fr1 [N]	Fr2 [N]
491	5,39	17,40	324,8	947	9019
505	5,95	16,21	294,3	1140	9420
558	7,39	14,40	236,7	1292	9927
575	8,02	13,68	218,2	1426	10294
650	8,85	14,02	197,7	1395	10322
795	11,01	13,79	159,0	1423	10532
1010	13,50	14,28	129,6	1363	10317
1080	14,90	13,84	117,5	1410	10432
1080	16,62	12,41	105,3	1576	11058
1080	18,53	11,13	94,5	1723	11705
1155	19,38	11,37	90,3	1699	11551
1155	21,39	10,31	81,8	1821	12166
1155	22,80	9,67	76,8	1895	12576
1155	26,60	8,29	65,8	2054	13601
1155	27,88	7,91	62,8	2098	13925
1365	31,15	8,36	56,2	2193	14709
1365	34,38	7,58	50,9	2270	15429
1365	38,70	6,73	45,2	2352	16329
1365	42,75	6,09	40,9	2414	17111
1365	48,13	5,41	36,4	2481	18000

IH083

Mn ₂ [Nm]	i	Pn ₁ [kW]	n ₂ [rpm]	Fr1 [N]	Fr2 [N]
1365	56,53	4,71	31,0	2559	18000
1535	71,48	4,19	24,5	2609	18000
1535	78,87	3,79	22,2	2646	18000
1535	85,56	3,50	20,4	2674	18000
1535	98,09	3,05	17,8	2717	18000
1535	112,78	2,65	15,5	2755	18000
1540	124,44	2,41	14,1	2779	18000
1530	142,15	2,10	12,3	2807	18000
1530	154,76	1,93	11,3	2824	18000
1535	162,35	1,84	10,8	2832	18000
1540	179,13	1,68	9,8	2849	18000
1535	195,07	1,53	9,0	2862	18000
1535	222,78	1,34	7,9	2880	18000

IH102

Mn ₂ [Nm]	i	Pn ₁ [kW]	n ₂ [rpm]	Fr1 [N]	Fr2 [N]
885	5,26	32,10	332,5	1872	9555
976	6,36	29,30	275,3	2050	9878
1031	7,05	27,90	248,2	1975	9408
1370	8,27	31,60	211,5	2131	9660
1497	9,99	28,60	175,1	2273	9796
1568	11,09	27,00	157,9	2336	9779
1927	13,32	27,60	131,3	2582	10718
2116	16,09	25,10	108,8	2801	11774
2226	17,85	23,80	98,0	2928	12590
2310	19,85	22,22	88,2	3045	13453
2310	21,44	20,56	81,6	3123	14102
2385	23,97	18,99	73,0	3198	14710
2385	25,89	17,58	67,6	3265	15401
2385	28,73	15,85	60,9	3346	16357
2730	30,72	16,96	57,0	3416	17349
2730	34,20	15,24	51,2	3484	18396
2390	38,45	11,86	45,5	3619	21009
2820	41,30	13,03	42,4	3573	19974
2820	45,82	11,75	38,2	3624	21091
2820	51,52	10,45	34,0	3676	22000

IH103

Mn ₂ [Nm]	i	Pn ₁ [kW]	n ₂ [rpm]	Fr1 [N]	Fr2 [N]
2990	55,47	10,51	31,6	3682	22000
2985	69,69	8,35	25,1	3766	22000
2990	79,82	7,30	21,9	3807	22000
2990	84,16	6,93	20,8	3822	22000
2990	93,36	6,24	18,7	3848	22000
2985	100,07	5,82	17,5	3865	22000
2990	120,84	4,82	14,5	3904	22000
2985	134,06	4,34	13,1	3922	22000
2990	143,42	4,06	12,2	3933	22000
2985	160,82	3,62	10,9	3950	22000
2985	181,07	3,21	9,7	3966	22000
2990	194,21	3,00	9,0	3975	22000
2985	215,45	2,70	8,1	3986	22000
2610	242,59	2,10	7,2	3995	22000

IH122

Mn ₂ [Nm]	i	Pn ₁ [kW]	n ₂ [rpm]	Fr1 [N]	Fr2 [N]
1155	5,27	41,80	331,8	973	13873
1210	5,78	40,00	303,0	1052	13972
1318	7,05	35,70	248,3	1285	14386
1687	7,74	41,60	226,0	1461	14886
1759	8,48	39,60	206,4	1620	15384
1886	10,35	34,80	169,2	1952	16625
2488	12,66	37,50	138,2	2162	17416
2593	13,86	35,70	126,2	2246	17753
2775	16,92	31,30	103,4	2505	19324
3168	19,32	31,30	90,6	2639	20249
3276	20,57	30,40	85,1	2723	20996
3422	22,52	29,00	77,7	2836	22104
3589	24,47	28,00	71,5	2931	23147
3615	27,49	25,10	63,7	3052	24663
3610	29,86	23,07	58,6	3130	25777
3907	33,00	22,60	53,0	3215	27161
4202	36,13	22,20	48,4	3286	28459
4270	44,10	18,48	39,7	3420	30000

IH123

Mn ₂ [Nm]	i	Pn ₁ [kW]	n ₂ [rpm]	Fr1 [N]	Fr2 [N]
4270	45,77	18,19	38,2	3442	30000

IH123

Mn ₂ [Nm]	i	Pn ₁ [kW]	n ₂ [rpm]	Fr1 [N]	Fr2 [N]
4270	55,87	14,90	31,3	3548	30000
4270	67,32	12,36	26,0	3630	30000
4270	73,71	11,29	23,7	3665	30000
4270	83,34	9,99	21,0	3707	30000
4270	89,97	9,25	19,4	3731	30000
4275	100,29	8,31	17,4	3761	30000
4270	108,34	7,68	16,1	3781	30000
4270	118,62	7,02	14,8	3803	30000
4270	128,18	6,49	13,7	3820	30000
4275	144,79	5,76	12,1	3844	30000
4265	155,22	5,36	11,3	3856	30000
4270	172,80	4,82	10,1	3874	30000
4270	189,19	4,40	9,2	3887	30000
4270	207,43	4,01	8,4	3900	30000
4275	230,92	3,61	7,6	3913	30000

IH142

Mn ₂ [Nm]	i	Pn ₁ [kW]	n ₂ [rpm]	Fr1 [N]	Fr2 [N]
1630	5,27	59,00	331,8	5427	17544
1778	6,36	53,40	275,4	6017	18654
1849	7,04	50,10	248,5	6374	19503
2424	7,84	59,00	223,1	6573	19885
2644	9,45	53,40	185,2	6503	18741
2732	10,47	49,80	167,1	6505	18062
3623	13,07	52,90	133,9	7258	20719
3928	15,75	47,60	111,1	7628	21957
4060	17,45	44,40	100,3	7877	23205
4589	20,04	43,70	87,3	8189	25066
5061	24,15	40,00	72,5	8585	28116
5286	26,76	37,70	65,4	8774	29879
5506	32,24	32,60	54,3	9071	33234
6309	38,85	31,00	45,0	9317	36807
6743	43,05	29,90	40,6	9435	38874

IH143

Mn ₂ [Nm]	i	Pn ₁ [kW]	n ₂ [rpm]	Fr1 [N]	Fr2 [N]
6835	48,35	27,56	36,2	9553	41292
6835	53,53	24,89	32,7	9647	43493
6835	59,22	22,50	29,6	9731	45753

IH143

Mn_2 [Nm]	i	Pn_1 [kW]	n_2 [rpm]	Fr_1 [N]	Fr_2 [N]
6835	62,99	21,15	27,8	9778	47174
6835	71,35	18,67	24,5	9865	50129
6835	79,07	16,85	22,1	9929	52660
6830	86,43	15,40	20,2	9979	54922
6835	96,21	13,85	18,2	10034	55000
6835	104,51	12,75	16,7	10073	55000
6830	115,92	11,49	15,1	10117	55000
6835	128,47	10,37	13,6	10156	55000
6835	139,55	9,55	12,5	10185	55000
6830	154,33	8,63	11,3	10217	55000
6835	185,96	7,17	9,4	10269	55000
6830	206,08	6,46	8,5	10293	55000

IHR041

Mn_2 [Nm]	i	Pn_1 [kW]	n_2 [rpm]	Fr_1 [N]	Fr_2 [N]
21	1,44	2,76	1217,4	976	578
21	2,00	1,98	875,0	1087	659
26	2,55	1,93	687,5	1100	698
26	2,71	1,81	644,7	1117	716
34	3,11	2,07	563,6	1083	712
38	3,59	2,00	487,7	1116	753
38	4,20	1,71	416,7	1153	804
38	5,00	1,44	350,0	1188	864
43	5,50	1,48	318,2	1186	876
43	6,09	1,33	287,3	1204	914
43	7,67	1,06	228,3	1238	1000
47	8,75	1,01	200,0	1243	1000

IHR051

Mn_2 [Nm]	i	Pn_1 [kW]	n_2 [rpm]	Fr_1 [N]	Fr_2 [N]
34	1,27	5,05	1375,0	793	1455
51	1,42	6,79	1233,0	616	1405
51	2,13	4,53	823,5	874	1660
60	2,57	4,41	680,6	898	1736
68	3,17	4,06	552,6	937	1835
77	3,69	3,94	474,6	979	1927
77	4,00	3,64	437,5	1011	1994
81	4,77	3,21	366,9	1055	2117
85	5,25	3,06	333,3	1070	2175

IHR051

Mn_2 [Nm]	i	Pn_1 [kW]	n2 [rpm]	Fr1 [N]	Fr2 [N]
85	5,82	2,76	300,8	1101	2271
85	7,33	2,19	238,6	1162	2498
86	8,38	1,94	209,0	1191	2500

IHR061

Mn_2 [Nm]	i	Pn_1 [kW]	n2 [rpm]	Fr1 [N]	Fr2 [N]
53	1,34	7,40	1302,3	1940	2110
103	2,13	9,16	823,5	2124	2407
102	2,57	7,49	680,6	2218	2560
111	3,17	6,62	552,6	2360	2781
128	3,69	6,56	474,6	2410	2916
128	4,00	6,05	437,5	2454	3012
137	4,77	5,43	366,9	2509	3190
145	5,25	5,22	333,3	2525	3276
145	5,82	4,71	300,8	2569	3412
145	7,33	3,74	238,6	2653	3700
145	8,38	3,27	209,0	2693	3700

IHR081

Mn_2 [Nm]	i	Pn_1 [kW]	n2 [rpm]	Fr1 [N]	Fr2 [N]
73	1,30	10,60	1349,0	851	2272
98	1,43	12,90	1225,0	871	2321
166	1,93	16,20	906,2	1368	2597
238	2,54	17,69	688,5	1541	2804
264	3,25	15,35	538,5	1788	3054
264	3,72	13,40	470,1	1930	3214
272	4,00	12,85	437,5	2007	3308
272	4,67	11,01	375,0	2154	3516
282	5,54	9,62	316,0	2270	3740
290	6,08	9,01	287,7	2318	3860
298	7,50	7,51	233,3	2437	4000
298	8,44	6,67	207,2	2504	4000

IHR101

Mn_2 [Nm]	i	Pn_1 [kW]	n2 [rpm]	Fr1 [N]	Fr2 [N]
135	1,29	19,80	1353,8	1743	2787
182	1,41	24,40	1240,9	1743	2834

IHR101

Mn_2 [Nm]	i	Pn_1 [kW]	n2 [rpm]	Fr1 [N]	Fr2 [N]
337	2,03	31,30	861,1	2423	3282
439	2,48	33,40	705,2	2452	3427
510	3,27	29,44	534,7	2748	3785
510	3,70	26,04	473,0	2888	3976
520	4,22	23,27	414,5	3021	4191
530	4,88	20,54	359,0	3134	4423
530	5,27	19,01	332,3	3196	4559
545	6,23	16,52	280,9	3294	4843
555	7,55	13,90	231,9	3402	5000
555	8,40	12,48	208,3	3459	5000

IHR121

Mn_2 [Nm]	i	Pn_1 [kW]	n2 [rpm]	Fr1 [N]	Fr2 [N]
122	1,23	18,70	1421,9	920	3501
164	1,42	21,90	1235,3	1084	3643
266	1,81	27,80	968,8	1699	4010
320	2,00	30,20	875,0	1806	4134
449	2,48	34,20	705,6	2129	4459
571	2,95	36,50	592,3	2419	4773
611	3,14	36,70	556,8	2475	4870
688	3,58	36,30	489,0	2637	5111
725	4,12	33,26	425,0	2807	5394
740	4,80	29,12	364,6	2944	5700
750	5,21	27,17	335,6	3012	5873
765	6,25	23,13	280,0	3147	6000
836	7,70	20,50	227,3	3224	6000

IHA32

Mn ₂ [Nm]	i	Pn ₁ [kW]	n ₂ [rpm]	Fr1 [N]	Fr2 [N]
58	5,38	1,65	260,3	330	1096
58	6,52	1,36	214,8	409	1169
54	8,11	1,02	172,6	373	1257
65	10,94	0,91	128,0	441	1389
58	13,25	0,67	105,7	363	1481
58	16,49	0,54	84,9	398	1593
65	20,26	0,49	69,1	453	1706
61	24,55	0,38	57,0	386	1818
68	30,55	0,34	45,8	374	1956
77	35,44	0,33	39,5	480	2000
77	44,10	0,27	31,8	398	2000
68	48,75	0,21	28,7	398	2000
81	60,67	0,20	23,1	472	2000

IHA33

Mn ₂ [Nm]	i	Pn ₁ [kW]	n ₂ [rpm]	Fr1 [N]	Fr2 [N]
84	51,32	0,26	27,3	472	2000
85	59,65	0,22	23,5	472	2000
87	72,27	0,19	19,4	472	2000
84	89,94	0,15	15,6	472	2000
85	110,51	0,12	12,7	472	2000
88	133,88	0,10	10,5	472	2000
82	166,61	0,08	8,4	472	2000
85	193,30	0,07	7,2	472	2000
79	240,55	0,05	5,8	472	2000
92	279,07	0,05	5,0	472	2000
76	347,29	0,03	4,0	472	2000

IHA41

Mn ₂ [Nm]	i	Pn ₁ [kW]	n ₂ [rpm]	Fr1 [N]	Fr2 [N]
21	1,45	2,19	966,7	330	512
21	2,94	1,08	475,5	330	648
26	4,75	0,83	294,7	330	760
26	5,45	0,72	256,7	330	796
21	7,88	0,40	177,8	330	900
17	10,83	0,24	129,2	330	1001

IHA42

Mn_2 [Nm]	i	Pn_1 [kW]	n2 [rpm]	Fr1 [N]	Fr2 [N]
101	5,38	2,87	260,3	330	2308
101	6,52	2,37	214,8	409	2461
94	8,11	1,77	172,6	369	2647
108	10,94	1,51	128,0	424	2924
101	13,25	1,16	105,7	381	3117
101	16,49	0,94	84,9	398	3353
108	20,26	0,81	69,1	432	3591
112	24,55	0,70	57,0	422	3828
120	30,55	0,60	45,8	359	4118
128	35,44	0,55	39,5	457	4300
120	44,10	0,42	31,8	371	4300
111	48,75	0,35	28,7	416	4300
120	60,67	0,30	23,1	428	4300

IHA43

Mn_2 [Nm]	i	Pn_1 [kW]	n2 [rpm]	Fr1 [N]	Fr2 [N]
129	51,32	0,39	27,3	427	4300
127	59,65	0,33	23,5	426	4300
127	72,27	0,27	19,4	409	4300
128	89,94	0,22	15,6	398	4300
127	110,51	0,18	12,7	403	4300
125	133,88	0,15	10,5	409	4300
128	166,61	0,12	8,4	398	4300
127	193,30	0,10	7,2	427	4300
132	240,55	0,09	5,8	398	4300
122	279,07	0,07	5,0	427	4300
133	347,29	0,06	4,0	398	4300

IHA51

Mn_2 [Nm]	i	Pn_1 [kW]	n2 [rpm]	Fr1 [N]	Fr2 [N]
34	1,45	3,55	966,7	330	1410
34	2,94	1,75	475,5	330	1786
43	4,75	1,37	294,7	330	2095
43	5,45	1,19	256,7	330	2194
34	7,88	0,65	177,8	330	2479
21	10,83	0,29	129,2	330	2757

IHA52

Mn ₂ [Nm]	i	Pn ₁ [kW]	n ₂ [rpm]	Fr1 [N]	Fr2 [N]
173	5,14	5,14	272,2	550	2842
173	6,22	4,25	225,0	682	3029
173	7,73	3,42	181,0	664	3256
216	9,64	3,42	145,2	827	3505
202	11,67	2,64	120,0	636	3735
202	14,50	2,13	96,5	664	4015
216	16,91	1,95	82,8	758	4227
208	20,46	1,55	68,4	659	4504
202	25,43	1,21	55,0	641	4842
216	29,89	1,10	46,8	752	5110
256	36,17	1,08	38,7	682	5445
238	44,95	0,81	31,1	620	5855
256	49,78	0,79	28,1	798	6000
246	61,87	0,61	22,6	642	6000

IHA53

Mn ₂ [Nm]	i	Pn ₁ [kW]	n ₂ [rpm]	Fr1 [N]	Fr2 [N]
256	49,80	0,80	28,1	330	6000
256	60,25	0,66	23,2	409	6000
254	74,88	0,53	18,7	398	6000
254	88,02	0,45	15,9	421	6000
256	111,61	0,36	12,5	390	6000
258	138,71	0,29	10,1	398	6000
258	163,05	0,25	8,6	421	6000
252	200,27	0,20	7,0	403	6000
256	235,41	0,17	6,0	421	6000
248	284,81	0,14	4,9	409	6000
252	353,98	0,11	4,0	398	6000

IHA61

Mn ₂ [Nm]	i	Pn ₁ [kW]	n ₂ [rpm]	Fr1 [N]	Fr2 [N]
77	1,33	8,73	1050,0	550	2053
77	2,50	4,65	560,0	550	2531
94	4,38	3,24	319,3	550	3053
77	7,75	1,50	180,7	550	3691
60	10,67	0,85	131,2	550	4106

IHA62

Mn ₂ [Nm]	i	Pn ₁ [kW]	n ₂ [rpm]	Fr1 [N]	Fr2 [N]
274	5,14	8,14	272,2	550	4195
274	6,22	6,72	225,0	682	4470
274	7,73	5,41	181,0	664	4806
332	9,64	5,26	145,2	801	5173
318	11,67	4,16	120,0	652	5512
302	14,50	3,18	96,5	634	5926
360	16,91	3,25	82,8	842	6238
332	20,46	2,48	68,4	627	6647
310	25,43	1,86	55,0	621	7147
324	29,89	1,66	46,8	734	7543
400	36,17	1,69	38,7	712	8000
376	44,95	1,28	31,1	621	8000
316	49,78	0,97	28,1	626	8000
376	61,87	0,93	22,6	789	8000

IHA63

Mn ₂ [Nm]	i	Pn ₁ [kW]	n ₂ [rpm]	Fr1 [N]	Fr2 [N]
408	49,80	1,28	28,1	330	8000
408	60,25	1,06	23,2	409	8000
410	74,88	0,85	18,7	398	8000
408	88,02	0,72	15,9	421	8000
408	111,61	0,57	12,5	390	8000
410	138,71	0,46	10,1	398	8000
410	163,05	0,39	8,6	421	8000
406	200,27	0,32	7,0	403	8000
412	235,41	0,27	6,0	421	8000
404	284,81	0,22	4,9	409	8000
406	353,98	0,18	4,0	398	8000

IH032

Mn ₂ [Nm]	i	Pn ₁ [kW]	n ₂ [rpm]	Fr1 [N]	Fr2 [N]
69	4,70	2,24	298,1	700	2996
76	6,23	1,86	224,8	817	3285
90	7,76	1,77	180,3	843	3410
94	8,87	1,62	157,9	894	3572
101	10,14	1,52	138,0	924	3694
105	11,76	1,36	119,0	975	3902
123	13,72	1,37	102,0	973	3927
123	14,66	1,28	95,5	1000	4054

IH032

Mn ₂ [Nm]	i	Pn ₁ [kW]	n ₂ [rpm]	Fr1 [N]	Fr2 [N]
137	16,77	1,25	83,5	1010	4113
145	18,20	1,22	76,9	1021	4178
145	19,90	1,11	70,4	1054	4366
145	22,68	0,98	61,7	1097	4654
145	23,83	0,93	58,7	1112	4766
145	26,39	0,84	53,0	1140	5003
146	29,70	0,75	47,1	1169	5287
171	32,89	0,79	42,6	1192	5500
171	37,92	0,69	36,9	1220	5500
171	41,40	0,63	33,8	1236	5500
171	47,25	0,55	29,6	1257	5500

IH033

Mn ₂ [Nm]	i	Pn ₁ [kW]	n ₂ [rpm]	Fr1 [N]	Fr2 [N]
170	53,59	0,49	26,1	1274	5500
172	66,78	0,40	21,0	1300	5500
172	74,84	0,36	18,7	1311	5500
169	99,27	0,27	14,1	1334	5500
172	108,05	0,25	13,0	1339	5500
169	123,71	0,21	11,3	1348	5500
173	143,33	0,19	9,8	1355	5500
166	178,61	0,14	7,8	1365	5500
173	197,17	0,14	7,1	1369	5500
175	245,70	0,11	5,7	1375	5500

IH042

Mn ₂ [Nm]	i	Pn ₁ [kW]	n ₂ [rpm]	Fr1 [N]	Fr2 [N]
116	5,46	3,24	256,3	434	3883
116	7,19	2,46	194,8	673	4382
152	8,91	2,60	157,1	628	4391
173	10,31	2,56	135,7	638	4449
181	11,80	2,34	118,6	709	4661
181	13,57	2,04	103,2	803	4983
181	15,96	1,73	87,7	897	5374
181	19,00	1,45	73,7	982	5820
181	21,00	1,32	66,7	1024	6088
188	23,15	1,24	60,5	1047	6274
188	26,04	1,10	53,8	1089	6600
202	27,50	1,12	50,9	1083	6600

IH042

Mn ₂ [Nm]	i	Pn ₁ [kW]	n ₂ [rpm]	Fr1 [N]	Fr2 [N]
238	30,45	1,19	46,0	1116	6600
238	34,10	1,07	41,1	1150	6600
238	37,76	0,96	37,1	1177	6600
238	43,75	0,83	32,0	1211	6600
238	47,53	0,76	29,4	1228	6600
238	54,25	0,67	25,8	1253	6600

IH043

Mn ₂ [Nm]	i	Pn ₁ [kW]	n ₂ [rpm]	Fr1 [N]	Fr2 [N]
256	61,83	0,65	22,6	1264	6600
256	76,67	0,52	18,3	1296	6600
256	87,05	0,46	16,1	1311	6600
256	114,55	0,35	12,2	1340	6600
256	125,69	0,32	11,1	1347	6600
256	142,04	0,28	9,9	1357	6600
256	165,38	0,24	8,5	1367	6600
256	205,07	0,19	6,8	1379	6600
256	227,50	0,18	6,2	1384	6600
256	282,10	0,14	5,0	1392	6600

IH052

Mn ₂ [Nm]	i	Pn ₁ [kW]	n ₂ [rpm]	Fr1 [N]	Fr2 [N]
188	5,73	5,01	244,4	259	4808
208	6,89	4,61	203,1	343	5024
244	8,53	4,37	164,2	398	5202
266	9,56	4,25	146,4	428	5292
280	11,51	3,71	121,6	548	5654
310	14,24	3,32	98,3	641	5993
324	16,59	2,98	84,4	718	6324
332	18,00	2,82	77,8	757	6513
332	19,97	2,54	70,1	821	6852
338	21,67	2,38	64,6	854	7058
338	24,71	2,09	56,7	921	7514
354	26,18	2,06	53,5	929	7588
354	28,44	1,90	49,2	966	7892
418	31,52	2,03	44,4	1008	8000
418	33,00	1,93	42,4	1026	8000
418	38,98	1,64	35,9	1083	8000
418	45,36	1,41	30,9	1127	8000

IH052

Mn_2 [Nm]	i	Pn_1 [kW]	n2 [rpm]	Fr1 [N]	Fr2 [N]
418	49,13	1,30	28,5	1148	8000
418	56,11	1,14	24,9	1179	8000

IH053

Mn_2 [Nm]	i	Pn_1 [kW]	n2 [rpm]	Fr1 [N]	Fr2 [N]
428	58,81	1,13	23,8	1185	8000
426	72,75	0,91	19,2	1226	8000
426	90,51	0,73	15,5	1260	8000
428	108,95	0,61	12,8	1283	8000
428	134,76	0,50	10,4	1305	8000
430	157,29	0,43	8,9	1319	8000
426	194,56	0,34	7,2	1334	8000
426	216,38	0,31	6,5	1340	8000
424	267,65	0,25	5,2	1352	8000

IH062

Mn_2 [Nm]	i	Pn_1 [kW]	n2 [rpm]	Fr1 [N]	Fr2 [N]
360	5,38	10,23	260,5	853	7772
396	5,93	10,19	235,9	860	7839
396	7,39	8,18	189,4	1250	8677
432	8,50	7,76	164,7	1332	8953
434	9,39	7,06	149,2	1475	9371
470	11,69	6,14	119,8	1652	10056
505	12,67	6,09	110,5	1660	10141
505	14,75	5,23	94,9	1827	10881
575	16,29	5,39	86,0	1791	10801
600	17,67	5,19	79,2	1837	11051
610	20,28	4,59	69,0	1946	11682
610	23,27	4,00	60,2	2061	12000
610	25,70	3,62	54,5	2134	12000
576	29,33	3,00	47,7	2259	12000
725	32,00	3,46	43,8	2274	12000
680	36,99	2,81	37,9	2379	12000
725	40,33	2,74	34,7	2391	12000
725	46,06	2,40	30,4	2447	12000

IH063

Mn ₂ [Nm]	i	Pn ₁ [kW]	n ₂ [rpm]	Fr1 [N]	Fr2 [N]
725	49,45	2,29	28,3	2474	12000
725	54,61	2,07	25,6	2509	12000
725	68,00	1,66	20,6	2574	12000
720	85,82	1,31	16,3	2630	12000
725	94,76	1,19	14,8	2650	12000
720	118,00	0,95	11,9	2688	12000
725	135,40	0,84	10,3	2707	12000
725	149,51	0,76	9,4	2720	12000
725	170,67	0,66	8,2	2735	12000
720	186,18	0,60	7,5	2744	12000
730	215,21	0,53	6,5	2757	12000
720	234,67	0,48	6,0	2764	12000
715	268,00	0,42	5,2	2774	12000

IH082

Mn ₂ [Nm]	i	Pn ₁ [kW]	n ₂ [rpm]	Fr1 [N]	Fr2 [N]
505	5,39	14,31	259,8	816	9756
505	5,95	12,97	235,4	1021	10188
575	7,39	11,87	189,3	1182	10739
575	8,02	10,95	174,5	1325	11135
650	8,85	11,21	158,2	1292	11171
795	11,01	11,03	127,2	1321	11409
1010	13,50	11,42	103,7	1258	11195
1080	14,90	11,07	94,0	1308	11324
1080	16,62	9,93	84,3	1484	11998
1080	18,53	8,90	75,6	1641	12695
1155	19,38	9,10	72,2	1615	12535
1155	21,39	8,25	65,5	1745	13197
1155	22,80	7,74	61,4	1824	13639
1155	26,60	6,63	52,6	1993	14744
1155	27,88	6,33	50,2	2040	15093
1365	31,15	6,69	44,9	2141	15937
1365	34,38	6,06	40,7	2222	16712
1365	38,70	5,39	36,2	2310	17681
1365	42,75	4,88	32,8	2376	18000
1365	48,13	4,33	29,1	2447	18000

IH083

Mn_2 [Nm]	i	Pn_1 [kW]	n_2 [rpm]	Fr_1 [N]	Fr_2 [N]
1365	56,53	3,77	24,8	2530	18000
1535	71,48	3,35	19,6	2583	18000
1535	78,87	3,04	17,8	2623	18000
1535	85,56	2,80	16,4	2653	18000
1535	98,09	2,44	14,3	2698	18000
1535	112,78	2,12	12,4	2739	18000
1540	124,44	1,93	11,2	2764	18000
1530	142,15	1,68	9,8	2794	18000
1530	154,76	1,54	9,1	2812	18000
1535	162,35	1,47	8,6	2821	18000
1540	179,13	1,34	7,8	2838	18000
1535	195,07	1,23	7,2	2852	18000
1535	222,78	1,07	6,3	2872	18000

IH102

Mn_2 [Nm]	i	Pn_1 [kW]	n_2 [rpm]	Fr_1 [N]	Fr_2 [N]
1106	5,26	32,10	266,0	1731	10378
1219	6,36	29,30	220,3	1919	10737
1288	7,05	27,90	198,6	1840	10244
1712	8,27	31,60	169,2	2006	10525
1871	9,99	28,60	140,1	2157	10686
1960	11,09	27,00	126,3	2223	10677
2240	13,32	25,67	105,1	2486	11693
2310	16,09	21,92	87,0	2719	12836
2310	17,85	19,76	78,4	2854	13715
2310	19,85	17,77	70,5	2979	14645
2310	21,44	16,45	65,3	3061	15343
2385	23,97	15,19	58,4	3141	16003
2385	25,89	14,06	54,1	3212	16747
2385	28,73	12,68	48,7	3299	17778
2730	30,72	13,57	45,6	3372	18842
2730	34,20	12,19	40,9	3446	19969
2390	38,45	9,49	36,4	3589	22000
2820	41,30	10,43	33,9	3540	21674
2820	45,82	9,40	30,6	3594	22000
2820	51,52	8,36	27,2	3649	22000

IH103

Mn ₂ [Nm]	i	Pn ₁ [kW]	n ₂ [rpm]	Fr1 [N]	Fr2 [N]
2990	55,47	8,41	25,2	3656	22000
2985	69,69	6,68	20,1	3745	22000
2990	79,82	5,84	17,5	3789	22000
2990	84,16	5,54	16,6	3804	22000
2990	93,36	4,99	15,0	3833	22000
2985	100,07	4,65	14,0	3850	22000
2990	120,84	3,86	11,6	3892	22000
2985	134,06	3,47	10,4	3911	22000
2990	143,42	3,25	9,8	3923	22000
2985	160,82	2,89	8,7	3941	22000
2985	181,07	2,57	7,7	3958	22000
2990	194,21	2,40	7,2	3967	22000
2985	215,45	2,16	6,5	3979	22000
2610	242,59	1,68	5,8	3989	22000

IH122

Mn ₂ [Nm]	i	Pn ₁ [kW]	n ₂ [rpm]	Fr1 [N]	Fr2 [N]
1444	5,27	41,80	265,4	778	15066
1513	5,78	40,00	242,4	862	15180
1648	7,05	35,70	198,6	1110	15643
2109	7,74	41,60	180,8	1297	16186
2198	8,48	39,60	165,2	1467	16726
2358	10,35	34,80	135,3	1819	18071
3110	12,66	37,50	110,6	2043	18939
3241	13,86	35,70	101,0	2132	19311
3468	16,92	31,30	82,7	2408	21011
3615	19,32	28,57	72,5	2550	22015
3615	20,57	26,83	68,1	2640	22820
3610	22,52	24,48	62,2	2760	24014
3615	24,47	22,56	57,2	2861	25137
3615	27,49	20,08	50,9	2989	26770
3610	29,86	18,46	46,9	3072	27970
4270	33,00	19,76	42,4	3163	29461
4270	36,13	18,05	38,8	3238	30000
4270	44,10	14,79	31,8	3381	30000

IH123

Mn ₂ [Nm]	i	Pn ₁ [kW]	n ₂ [rpm]	Fr1 [N]	Fr2 [N]
4270	45,77	14,55	30,6	3405	30000

IH123

Mn ₂ [Nm]	i	Pn ₁ [kW]	n ₂ [rpm]	Fr1 [N]	Fr2 [N]
4270	55,87	11,92	25,1	3518	30000
4270	67,32	9,89	20,8	3605	30000
4270	73,71	9,03	19,0	3641	30000
4270	83,34	7,99	16,8	3686	30000
4270	89,97	7,40	15,6	3711	30000
4275	100,29	6,65	14,0	3744	30000
4270	108,34	6,15	12,9	3765	30000
4270	118,62	5,61	11,8	3788	30000
4270	128,18	5,20	10,9	3806	30000
4275	144,79	4,60	9,7	3832	30000
4265	155,22	4,29	9,0	3845	30000
4270	172,80	3,85	8,1	3864	30000
4270	189,19	3,52	7,4	3878	30000
4270	207,43	3,21	6,8	3891	30000
4275	230,92	2,89	6,1	3905	30000

IH142

Mn ₂ [Nm]	i	Pn ₁ [kW]	n ₂ [rpm]	Fr1 [N]	Fr2 [N]
2038	5,27	59,00	265,4	5102	19072
2222	6,36	53,40	220,3	5730	20279
2311	7,04	50,10	198,8	6109	21198
3030	7,84	59,00	178,5	6321	21620
3305	9,45	53,40	148,2	6247	20432
3415	10,47	49,80	133,7	6249	19728
4528	13,07	52,90	107,1	7050	22593
4909	15,75	47,60	88,9	7443	23946
5075	17,45	44,40	80,2	7708	25294
5736	20,04	43,70	69,8	8040	27303
5780	24,15	36,55	58,0	8462	30588
5780	26,76	32,98	52,3	8663	32488
6835	32,24	32,37	43,4	8978	36102
6835	38,85	26,87	36,0	9240	39950
6835	43,05	24,24	32,5	9365	42176

IH143

Mn ₂ [Nm]	i	Pn ₁ [kW]	n ₂ [rpm]	Fr1 [N]	Fr2 [N]
6835	48,35	22,05	29,0	9492	44781
6835	53,53	19,91	26,1	9591	47153
6835	59,22	18,00	23,6	9680	49587

IH143

Mn ₂ [Nm]	i	Pn ₁ [kW]	n ₂ [rpm]	Fr1 [N]	Fr2 [N]
6835	62,99	16,92	22,2	9731	51117
6835	71,35	14,94	19,6	9823	54301
6835	79,07	13,48	17,7	9891	55000
6830	86,43	12,32	16,2	9945	55000
6835	96,21	11,08	14,6	10003	55000
6835	104,51	10,20	13,4	10044	55000
6830	115,92	9,19	12,1	10091	55000
6835	128,47	8,30	10,9	10133	55000
6835	139,55	7,64	10,0	10164	55000
6830	154,33	6,90	9,1	10198	55000
6835	185,96	5,73	7,5	10252	55000
6830	206,08	5,17	6,8	10279	55000

IHR041

Mn ₂ [Nm]	i	Pn ₁ [kW]	n ₂ [rpm]	Fr1 [N]	Fr2 [N]
21	1,44	2,21	973,9	951	624
21	2,00	1,59	700,0	1069	711
26	2,55	1,54	550,0	1082	754
26	2,71	1,45	515,8	1100	774
34	3,11	1,65	450,9	1065	770
38	3,59	1,60	390,2	1100	813
38	4,20	1,37	333,3	1139	869
38	5,00	1,15	280,0	1176	933
43	5,50	1,18	254,6	1174	947
43	6,09	1,07	229,8	1193	988
43	7,67	0,85	182,6	1230	1000
47	8,75	0,81	160,0	1235	1000

IHR051

Mn ₂ [Nm]	i	Pn ₁ [kW]	n ₂ [rpm]	Fr1 [N]	Fr2 [N]
34	1,27	4,04	1100,0	754	1570
51	1,42	5,43	986,4	566	1518
51	2,13	3,63	658,8	841	1793
60	2,57	3,53	544,4	866	1876
68	3,17	3,25	442,1	908	1983
77	3,69	3,16	379,7	952	2083
77	4,00	2,91	350,0	987	2155
81	4,77	2,57	293,6	1033	2288
85	5,25	2,45	266,7	1049	2351

IHR051

Mn_2 [Nm]	i	Pn_1 [kW]	n2 [rpm]	Fr1 [N]	Fr2 [N]
85	5,82	2,21	240,6	1083	2454
85	7,33	1,75	190,9	1147	2500
86	8,38	1,55	167,2	1178	2500

IHR061

Mn_2 [Nm]	i	Pn_1 [kW]	n2 [rpm]	Fr1 [N]	Fr2 [N]
66	1,34	7,40	1041,9	1874	2277
103	2,13	7,33	658,8	2070	2600
102	2,57	5,99	544,4	2170	2764
111	3,17	5,30	442,1	2321	3003
128	3,69	5,25	379,7	2374	3149
128	4,00	4,84	350,0	2421	3252
137	4,77	4,34	293,6	2479	3444
145	5,25	4,17	266,7	2496	3537
145	5,82	3,77	240,6	2543	3684
145	7,33	2,99	190,9	2632	3700
145	8,38	2,62	167,2	2675	3700

IHR081

Mn_2 [Nm]	i	Pn_1 [kW]	n2 [rpm]	Fr1 [N]	Fr2 [N]
91	1,30	10,60	1079,2	711	2454
122	1,43	12,90	980,0	733	2507
196	1,93	15,34	725,0	1262	2804
238	2,54	14,15	550,8	1446	3029
264	3,25	12,28	430,8	1708	3298
264	3,72	10,72	376,1	1859	3471
272	4,00	10,28	350,0	1941	3572
272	4,67	8,81	300,0	2098	3796
282	5,54	7,70	252,8	2221	4000
290	6,08	7,20	230,1	2272	4000
298	7,50	6,00	186,7	2398	4000
298	8,44	5,33	165,8	2470	4000

IHR101

Mn_2 [Nm]	i	Pn_1 [kW]	n2 [rpm]	Fr1 [N]	Fr2 [N]
169	1,29	19,80	1083,0	1601	3010
228	1,41	24,40	992,7	1601	3061

6.3 IH/IHA GEAR REDUCER - 1400 rpm

IHR101

Mn_2 [Nm]	i	Pn_1 [kW]	n2 [rpm]	Fr1 [N]	Fr2 [N]
384	2,03	28,56	688,9	2324	3544
468	2,48	28,50	564,2	2356	3702
510	3,27	23,55	427,8	2670	4088
510	3,70	20,83	378,4	2820	4294
520	4,22	18,61	331,6	2961	4525
530	4,88	16,43	287,2	3081	4775
530	5,27	15,21	265,8	3147	4922
545	6,23	13,22	224,7	3251	5000
555	7,55	11,12	185,5	3366	5000
555	8,40	9,99	166,7	3427	5000

IHR121

Mn_2 [Nm]	i	Pn_1 [kW]	n2 [rpm]	Fr1 [N]	Fr2 [N]
152	1,23	18,70	1137,5	727	3780
205	1,42	21,90	988,2	902	3934
332	1,81	27,80	775,0	1556	4329
400	2,00	30,20	700,0	1670	4463
561	2,48	34,20	564,5	2014	4813
680	2,95	34,78	473,9	2322	5152
700	3,14	33,66	445,4	2382	5257
725	3,58	30,62	391,2	2555	5517
725	4,12	26,61	340,0	2735	5821
740	4,80	23,30	291,7	2881	6000
750	5,21	21,74	268,5	2953	6000
765	6,25	18,50	224,0	3097	6000
850	7,70	16,68	181,8	3179	6000

IHA32

Mn ₂ [Nm]	i	Pn ₁ [kW]	n ₂ [rpm]	Fr1 [N]	Fr2 [N]
58	5,38	1,33	211,9	330	1174
58	6,52	1,10	174,9	409	1252
54	8,11	0,82	140,6	373	1346
65	10,94	0,73	104,2	441	1487
58	13,25	0,54	86,0	363	1586
58	16,49	0,43	69,1	398	1705
65	20,26	0,39	56,3	453	1827
61	24,55	0,31	46,4	386	1947
68	30,55	0,27	37,3	374	2000
77	35,44	0,27	32,2	480	2000
77	44,10	0,21	25,9	398	2000
68	48,75	0,17	23,4	398	2000
81	60,67	0,16	18,8	472	2000

IHA33

Mn ₂ [Nm]	i	Pn ₁ [kW]	n ₂ [rpm]	Fr1 [N]	Fr2 [N]
84	51,32	0,21	22,2	472	2000
85	59,65	0,18	19,1	472	2000
87	72,27	0,15	15,8	472	2000
84	89,94	0,12	12,7	472	2000
85	110,51	0,10	10,3	472	2000
88	133,88	0,08	8,5	472	2000
82	166,61	0,06	6,8	472	2000
85	193,30	0,06	5,9	472	2000
79	240,55	0,04	4,7	472	2000
92	279,07	0,04	4,1	472	2000
76	347,29	0,03	3,3	472	2000

IHA41

Mn ₂ [Nm]	i	Pn ₁ [kW]	n ₂ [rpm]	Fr1 [N]	Fr2 [N]
21	1,45	1,77	787,1	330	548
21	2,94	0,87	387,2	330	694
26	4,75	0,67	240,0	330	814
26	5,45	0,58	209,0	330	852
21	7,88	0,32	144,8	330	963
17	10,83	0,19	105,2	330	1072

IHA42

Mn_2 [Nm]	i	Pn_1 [kW]	n2 [rpm]	Fr1 [N]	Fr2 [N]
101	5,38	2,31	211,9	330	2472
101	6,52	1,91	174,9	409	2635
94	8,11	1,43	140,6	369	2834
108	10,94	1,22	104,2	424	3131
101	13,25	0,94	86,0	381	3338
101	16,49	0,75	69,1	398	3590
108	20,26	0,66	56,3	432	3846
112	24,55	0,56	46,4	422	4100
120	30,55	0,48	37,3	359	4300
128	35,44	0,44	32,2	457	4300
120	44,10	0,34	25,9	371	4300
111	48,75	0,28	23,4	416	4300
120	60,67	0,24	18,8	428	4300

IHA43

Mn_2 [Nm]	i	Pn_1 [kW]	n2 [rpm]	Fr1 [N]	Fr2 [N]
129	51,32	0,32	22,2	427	4300
127	59,65	0,27	19,1	426	4300
127	72,27	0,22	15,8	409	4300
128	89,94	0,18	12,7	398	4300
127	110,51	0,14	10,3	403	4300
125	133,88	0,12	8,5	409	4300
128	166,61	0,10	6,8	398	4300
127	193,30	0,08	5,9	427	4300
132	240,55	0,07	4,7	398	4300
122	279,07	0,05	4,1	427	4300
133	347,29	0,05	3,3	398	4300

IHA51

Mn_2 [Nm]	i	Pn_1 [kW]	n2 [rpm]	Fr1 [N]	Fr2 [N]
34	1,45	2,86	787,1	330	1510
34	2,94	1,41	387,2	330	1913
43	4,75	1,10	240,0	330	2243
43	5,45	0,96	209,0	330	2349
34	7,88	0,53	144,8	330	2655
21	10,83	0,24	105,2	330	2953

IHA52

Mn ₂ [Nm]	i	Pn ₁ [kW]	n ₂ [rpm]	Fr1 [N]	Fr2 [N]
173	5,14	4,14	221,7	550	3044
173	6,22	3,42	183,2	682	3243
173	7,73	2,75	147,4	664	3487
216	9,64	2,76	118,2	827	3753
202	11,67	2,13	97,7	636	3999
202	14,50	1,72	78,6	664	4300
216	16,91	1,57	67,4	758	4526
208	20,46	1,25	55,7	659	4823
202	25,43	0,98	44,8	641	5185
216	29,89	0,89	38,1	752	5472
256	36,17	0,87	31,5	682	5831
238	44,95	0,65	25,4	620	6000
256	49,78	0,63	22,9	798	6000
246	61,87	0,49	18,4	642	6000

IHA53

Mn ₂ [Nm]	i	Pn ₁ [kW]	n ₂ [rpm]	Fr1 [N]	Fr2 [N]
256	49,80	0,65	22,9	330	6000
256	60,25	0,53	18,9	409	6000
254	74,88	0,43	15,2	398	6000
254	88,02	0,36	12,9	421	6000
256	111,61	0,29	10,2	390	6000
258	138,71	0,23	8,2	398	6000
258	163,05	0,20	7,0	421	6000
252	200,27	0,16	5,7	403	6000
256	235,41	0,14	4,8	421	6000
248	284,81	0,11	4,0	409	6000
252	353,98	0,09	3,2	398	6000

IHA61

Mn ₂ [Nm]	i	Pn ₁ [kW]	n ₂ [rpm]	Fr1 [N]	Fr2 [N]
77	1,33	7,04	855,0	550	2198
77	2,50	3,75	456,0	550	2711
94	4,38	2,61	260,0	550	3269
77	7,75	1,21	147,1	550	3953
60	10,67	0,69	106,9	550	4397

IHA62

Mn ₂ [Nm]	i	Pn ₁ [kW]	n ₂ [rpm]	Fr1 [N]	Fr2 [N]
274	5,14	6,56	221,7	550	4492
274	6,22	5,42	183,2	682	4787
274	7,73	4,36	147,4	664	5147
332	9,64	4,24	118,2	801	5540
318	11,67	3,36	97,7	652	5903
302	14,50	2,56	78,6	634	6346
360	16,91	2,62	67,4	842	6681
332	20,46	2,00	55,7	627	7119
310	25,43	1,50	44,8	621	7654
324	29,89	1,33	38,1	734	8000
400	36,17	1,36	31,5	712	8000
376	44,95	1,03	25,4	621	8000
316	49,78	0,78	22,9	626	8000
376	61,87	0,75	18,4	789	8000

IHA63

Mn ₂ [Nm]	i	Pn ₁ [kW]	n ₂ [rpm]	Fr1 [N]	Fr2 [N]
408	49,80	1,03	22,9	330	8000
408	60,25	0,85	18,9	409	8000
410	74,88	0,69	15,2	398	8000
408	88,02	0,58	12,9	421	8000
408	111,61	0,46	10,2	390	8000
410	138,71	0,37	8,2	398	8000
410	163,05	0,32	7,0	421	8000
406	200,27	0,25	5,7	403	8000
412	235,41	0,22	4,8	421	8000
404	284,81	0,18	4,0	409	8000
406	353,98	0,14	3,2	398	8000

IH032

Mn ₂ [Nm]	i	Pn ₁ [kW]	n ₂ [rpm]	Fr1 [N]	Fr2 [N]
69	4,70	1,81	242,8	682	3253
76	6,23	1,50	183,0	803	3568
90	7,76	1,43	146,9	829	3712
94	8,87	1,31	128,6	881	3887
101	10,14	1,23	112,4	912	4022
105	11,76	1,10	96,9	964	4248
123	13,72	1,10	83,1	962	4287
123	14,66	1,03	77,8	990	4422

IH032

Mn_2 [Nm]	i	Pn_1 [kW]	n_2 [rpm]	Fr_1 [N]	Fr_2 [N]
137	16,77	1,01	68,0	1000	4495
145	18,20	0,98	62,6	1012	4569
145	19,90	0,90	57,3	1045	4771
145	22,68	0,79	50,3	1089	5079
145	23,83	0,75	47,8	1105	5199
145	26,39	0,68	43,2	1134	5453
146	29,70	0,61	38,4	1164	5500
171	32,89	0,64	34,7	1187	5500
171	37,92	0,56	30,1	1216	5500
171	41,40	0,51	27,5	1232	5500
171	47,25	0,45	24,1	1253	5500

IH033

Mn_2 [Nm]	i	Pn_1 [kW]	n_2 [rpm]	Fr_1 [N]	Fr_2 [N]
170	53,59	0,40	21,3	1271	5500
172	66,78	0,32	17,1	1297	5500
172	74,84	0,29	15,2	1308	5500
169	99,27	0,21	11,5	1332	5500
172	108,05	0,20	10,6	1338	5500
169	123,71	0,17	9,2	1346	5500
173	143,33	0,15	8,0	1354	5500
166	178,61	0,12	6,4	1364	5500
173	197,17	0,11	5,8	1368	5500
175	245,70	0,09	4,6	1375	5500

IH042

Mn_2 [Nm]	i	Pn_1 [kW]	n_2 [rpm]	Fr_1 [N]	Fr_2 [N]
116	5,46	2,61	208,7	409	4219
116	7,19	1,99	158,6	654	4753
152	8,91	2,10	127,9	608	4783
173	10,31	2,06	110,5	619	4855
181	11,80	1,89	96,6	691	5087
181	13,57	1,64	84,0	787	5431
181	15,96	1,40	71,4	883	5850
181	19,00	1,17	60,0	971	6328
181	21,00	1,06	54,3	1014	6600
188	23,15	1,00	49,2	1038	6600
188	26,04	0,89	43,8	1081	6600
202	27,50	0,90	41,5	1074	6600

IH042

Mn ₂ [Nm]	i	Pn ₁ [kW]	n ₂ [rpm]	Fr1 [N]	Fr2 [N]
238	30,45	0,96	37,4	1109	6600
238	34,10	0,86	33,4	1143	6600
238	37,76	0,78	30,2	1170	6600
238	43,75	0,67	26,1	1206	6600
238	47,53	0,62	24,0	1223	6600
238	54,25	0,54	21,0	1249	6600

IH043

Mn ₂ [Nm]	i	Pn ₁ [kW]	n ₂ [rpm]	Fr1 [N]	Fr2 [N]
256	61,83	0,52	18,4	1260	6600
256	76,67	0,42	14,9	1292	6600
256	87,05	0,37	13,1	1309	6600
256	114,55	0,28	9,9	1337	6600
256	125,69	0,26	9,1	1345	6600
256	142,04	0,23	8,0	1355	6600
256	165,38	0,19	6,9	1365	6600
256	205,07	0,16	5,6	1378	6600
256	227,50	0,14	5,0	1383	6600
256	282,10	0,11	4,0	1391	6600

IH052

Mn ₂ [Nm]	i	Pn ₁ [kW]	n ₂ [rpm]	Fr1 [N]	Fr2 [N]
188	5,73	4,04	199,1	231	5228
208	6,89	3,71	165,4	317	5469
244	8,53	3,52	133,7	373	5675
266	9,56	3,42	119,2	403	5781
280	11,51	2,99	99,0	527	6174
310	14,24	2,68	80,1	622	6550
324	16,59	2,40	68,7	701	6910
332	18,00	2,27	63,3	741	7116
332	19,97	2,05	57,1	806	7478
338	21,67	1,92	52,6	841	7702
338	24,71	1,68	46,1	909	8000
354	26,18	1,66	43,5	917	8000
354	28,44	1,53	40,1	955	8000
418	31,52	1,63	36,2	999	8000
418	33,00	1,56	34,5	1017	8000
418	38,98	1,32	29,2	1075	8000
418	45,36	1,13	25,1	1121	8000

IH052

Mn ₂ [Nm]	i	Pn ₁ [kW]	n ₂ [rpm]	Fr1 [N]	Fr2 [N]
418	49,13	1,05	23,2	1142	8000
418	56,11	0,92	20,3	1174	8000

IH053

Mn ₂ [Nm]	i	Pn ₁ [kW]	n ₂ [rpm]	Fr1 [N]	Fr2 [N]
428	58,81	0,92	19,4	1180	8000
426	72,75	0,74	15,7	1222	8000
426	90,51	0,59	12,6	1256	8000
428	108,95	0,49	10,5	1280	8000
428	134,76	0,40	8,5	1303	8000
430	157,29	0,34	7,2	1317	8000
426	194,56	0,28	5,9	1332	8000
426	216,38	0,25	5,3	1339	8000
424	267,65	0,20	4,3	1350	8000

IH062

Mn ₂ [Nm]	i	Pn ₁ [kW]	n ₂ [rpm]	Fr1 [N]	Fr2 [N]
360	5,38	8,25	212,1	803	8456
396	5,93	8,21	192,1	811	8542
396	7,39	6,60	154,2	1211	9439
432	8,50	6,26	134,1	1295	9748
434	9,39	5,69	121,5	1441	10196
470	11,69	4,95	97,5	1623	10942
505	12,67	4,91	90,0	1630	11047
505	14,75	4,22	77,3	1802	11839
575	16,29	4,35	70,0	1765	11780
600	17,67	4,18	64,5	1812	12000
610	20,28	3,70	56,2	1923	12000
610	23,27	3,23	49,0	2041	12000
610	25,70	2,92	44,4	2117	12000
576	29,33	2,42	38,9	2244	12000
725	32,00	2,79	35,6	2259	12000
680	36,99	2,26	30,8	2368	12000
725	40,33	2,21	28,3	2380	12000
725	46,06	1,94	24,8	2437	12000

IH063

Mn ₂ [Nm]	i	Pn ₁ [kW]	n ₂ [rpm]	Fr1 [N]	Fr2 [N]
725	49,45	1,84	23,1	2465	12000
725	54,61	1,67	20,9	2500	12000
725	68,00	1,34	16,8	2568	12000
720	85,82	1,05	13,3	2625	12000
725	94,76	0,96	12,0	2645	12000
720	118,00	0,77	9,7	2684	12000
725	135,40	0,67	8,4	2704	12000
725	149,51	0,61	7,6	2717	12000
725	170,67	0,53	6,7	2732	12000
720	186,18	0,49	6,1	2742	12000
730	215,21	0,43	5,3	2755	12000
720	234,67	0,39	4,9	2762	12000
715	268,00	0,34	4,2	2772	12000

IH082

Mn ₂ [Nm]	i	Pn ₁ [kW]	n ₂ [rpm]	Fr1 [N]	Fr2 [N]
505	5,39	11,54	211,6	761	10594
505	5,95	10,46	191,7	971	11056
575	7,39	9,57	154,2	1136	11669
575	8,02	8,83	142,1	1283	12092
650	8,85	9,04	128,8	1249	12152
795	11,01	8,89	103,6	1279	12448
1010	13,50	9,21	84,4	1214	12282
1080	14,90	8,93	76,5	1266	12441
1080	16,62	8,00	68,6	1446	13164
1080	18,53	7,18	61,5	1607	13909
1155	19,38	7,34	58,8	1580	13760
1155	21,39	6,65	53,3	1714	14468
1155	22,80	6,24	50,0	1794	14941
1155	26,60	5,35	42,9	1967	16125
1155	27,88	5,10	40,9	2015	16498
1365	31,15	5,39	36,6	2120	17402
1365	34,38	4,89	33,2	2203	18000
1365	38,70	4,34	29,4	2293	18000
1365	42,75	3,93	26,7	2361	18000
1365	48,13	3,49	23,7	2433	18000

IH083

Mn ₂ [Nm]	i	Pn ₁ [kW]	n ₂ [rpm]	Fr1 [N]	Fr2 [N]
1365	56,53	3,04	20,2	2518	18000
1535	71,48	2,70	15,9	2572	18000
1535	78,87	2,45	14,4	2613	18000
1535	85,56	2,26	13,3	2644	18000
1535	98,09	1,97	11,6	2691	18000
1535	112,78	1,71	10,1	2732	18000
1540	124,44	1,56	9,2	2758	18000
1530	142,15	1,35	8,0	2789	18000
1530	154,76	1,24	7,4	2807	18000
1535	162,35	1,19	7,0	2816	18000
1540	179,13	1,08	6,4	2834	18000
1535	195,07	0,99	5,8	2848	18000
1535	222,78	0,87	5,1	2868	18000

IH102

Mn ₂ [Nm]	i	Pn ₁ [kW]	n ₂ [rpm]	Fr1 [N]	Fr2 [N]
1300	5,26	30,41	216,6	1672	11427
1445	6,36	27,99	179,4	1865	11846
1598	7,05	27,90	161,7	1784	11371
1805	8,27	26,86	137,8	1954	11706
2020	9,99	24,89	114,1	2109	11930
2170	11,09	24,10	102,8	2177	11956
2240	13,32	20,70	85,6	2445	13061
2310	16,09	17,67	70,8	2684	14302
2310	17,85	15,93	63,9	2823	15244
2310	19,85	14,33	57,4	2951	16239
2310	21,44	13,26	53,2	3036	16988
2385	23,97	12,25	47,6	3117	17712
2385	25,89	11,34	44,0	3190	18508
2385	28,73	10,22	39,7	3279	19612
2730	30,72	10,94	37,1	3354	20734
2730	34,20	9,83	33,3	3429	21942
2390	38,45	7,65	29,6	3576	22000
2820	41,30	8,41	27,6	3526	22000
2820	45,82	7,58	24,9	3582	22000
2820	51,52	6,74	22,1	3638	22000

IH103

Mn ₂ [Nm]	i	Pn ₁ [kW]	n ₂ [rpm]	Fr1 [N]	Fr2 [N]
2990	55,47	6,78	20,6	3645	22000
2985	69,69	5,39	16,4	3736	22000
2990	79,82	4,71	14,3	3781	22000
2990	84,16	4,47	13,6	3797	22000
2990	93,36	4,03	12,2	3826	22000
2985	100,07	3,75	11,4	3844	22000
2990	120,84	3,11	9,4	3887	22000
2985	134,06	2,80	8,5	3907	22000
2990	143,42	2,62	8,0	3919	22000
2985	160,82	2,33	7,1	3937	22000
2985	181,07	2,07	6,3	3955	22000
2990	194,21	1,94	5,9	3964	22000
2985	215,45	1,74	5,3	3977	22000
2610	242,59	1,35	4,7	3986	22000

IH122

Mn ₂ [Nm]	i	Pn ₁ [kW]	n ₂ [rpm]	Fr1 [N]	Fr2 [N]
1791	5,27	41,80	216,1	697	16577
1876	5,78	40,00	197,4	783	16729
2044	7,05	35,70	161,7	1037	17284
2616	7,74	41,60	147,2	1229	17880
2726	8,48	39,60	134,5	1402	18473
2890	10,35	34,39	110,2	1764	19943
3180	12,66	30,92	90,0	1993	20932
3325	13,86	29,53	82,2	2085	21359
3470	16,92	25,25	67,4	2367	23209
3615	19,32	23,03	59,0	2513	24314
3615	20,57	21,63	55,4	2605	25176
3610	22,52	19,73	50,6	2728	26455
3615	24,47	18,19	46,6	2832	27657
3615	27,49	16,19	41,5	2964	29406
3610	29,86	14,88	38,2	3048	30000
4270	33,00	15,93	34,5	3141	30000
4270	36,13	14,55	31,6	3218	30000
4270	44,10	11,92	25,9	3365	30000

IH123

Mn ₂ [Nm]	i	Pn ₁ [kW]	n ₂ [rpm]	Fr1 [N]	Fr2 [N]
4270	45,77	11,73	24,9	3389	30000

IH123

Mn ₂ [Nm]	i	Pn ₁ [kW]	n ₂ [rpm]	Fr1 [N]	Fr2 [N]
4270	55,87	9,61	20,4	3505	30000
4270	67,32	7,97	16,9	3594	30000
4270	73,71	7,28	15,5	3632	30000
4270	83,34	6,44	13,7	3678	30000
4270	89,97	5,97	12,7	3704	30000
4275	100,29	5,36	11,4	3737	30000
4270	108,34	4,96	10,5	3759	30000
4270	118,62	4,53	9,6	3782	30000
4270	128,18	4,19	8,9	3801	30000
4275	144,79	3,71	7,9	3827	30000
4265	155,22	3,45	7,3	3840	30000
4270	172,80	3,11	6,6	3860	30000
4270	189,19	2,84	6,0	3874	30000
4270	207,43	2,59	5,5	3888	30000
4275	230,92	2,33	4,9	3902	30000

IH142

Mn ₂ [Nm]	i	Pn ₁ [kW]	n ₂ [rpm]	Fr1 [N]	Fr2 [N]
2528	5,27	59,00	216,1	4966	21055
2757	6,36	53,40	179,4	5610	22389
2866	7,04	50,10	161,9	5999	23386
3758	7,84	59,00	145,4	6216	23880
4099	9,45	53,40	120,6	6140	22773
4236	10,47	49,80	108,8	6142	22114
5275	13,07	49,68	87,2	6963	25197
5640	15,75	44,09	72,4	7366	26714
5710	17,45	40,28	65,3	7638	28172
5780	20,04	35,50	56,9	7978	30336
5780	24,15	29,47	47,2	8410	33854
5780	26,76	26,59	42,6	8616	35889
6835	32,24	26,10	35,4	8940	39759
6835	38,85	21,66	29,3	9208	43880
6835	43,05	19,54	26,5	9337	46264

IH143

Mn ₂ [Nm]	i	Pn ₁ [kW]	n ₂ [rpm]	Fr1 [N]	Fr2 [N]
6835	48,35	17,78	23,6	9466	49054
6835	53,53	16,06	21,3	9568	51593
6835	59,22	14,51	19,2	9659	54200

IH143

Mn_2 [Nm]	i	Pn_1 [kW]	n2 [rpm]	Fr1 [N]	Fr2 [N]
6835	62,99	13,64	18,1	9711	55000
6835	71,35	12,04	16,0	9806	55000
6835	79,07	10,87	14,4	9876	55000
6830	86,43	9,94	13,2	9930	55000
6835	96,21	8,93	11,8	9990	55000
6835	104,51	8,22	10,9	10032	55000
6830	115,92	7,41	9,8	10080	55000
6835	128,47	6,69	8,9	10123	55000
6835	139,55	6,16	8,2	10155	55000
6830	154,33	5,56	7,4	10190	55000
6835	185,96	4,62	6,1	10246	55000
6830	206,08	4,17	5,5	10273	55000

IHR041

Mn_2 [Nm]	i	Pn_1 [kW]	n2 [rpm]	Fr1 [N]	Fr2 [N]
21	1,44	1,78	793,0	940	674
21	2,00	1,28	570,0	1061	768
26	2,55	1,24	447,9	1075	815
26	2,71	1,17	420,0	1094	836
34	3,11	1,33	367,1	1057	834
38	3,59	1,29	317,7	1093	881
38	4,20	1,10	271,4	1134	940
38	5,00	0,93	228,0	1171	1000
43	5,50	0,95	207,3	1169	1000
43	6,09	0,86	187,2	1189	1000
43	7,67	0,68	148,7	1226	1000
47	8,75	0,65	130,3	1231	1000

IHR051

Mn_2 [Nm]	i	Pn_1 [kW]	n2 [rpm]	Fr1 [N]	Fr2 [N]
34	1,27	3,26	895,7	739	1694
51	1,42	4,38	803,2	545	1644
51	2,13	2,92	536,5	827	1938
60	2,57	2,84	443,3	853	2030
68	3,17	2,62	360,0	896	2147
77	3,69	2,54	309,1	941	2255
77	4,00	2,35	285,0	977	2333
81	4,77	2,07	239,0	1024	2476
85	5,25	1,97	217,1	1041	2500

IHR051

Mn_2 [Nm]	i	Pn_1 [kW]	n_2 [rpm]	Fr_1 [N]	Fr_2 [N]
85	5,82	1,78	195,9	1075	2500
85	7,33	1,41	155,4	1141	2500
86	8,38	1,25	136,1	1172	2500

IHR061

Mn_2 [Nm]	i	Pn_1 [kW]	n_2 [rpm]	Fr_1 [N]	Fr_2 [N]
68	1,34	6,17	848,4	1847	2457
103	2,13	5,91	536,5	2047	2808
102	2,57	4,83	443,3	2150	2986
111	3,17	4,27	360,0	2305	3242
128	3,69	4,23	309,1	2358	3399
128	4,00	3,90	285,0	2407	3510
137	4,77	3,50	239,0	2467	3700
145	5,25	3,37	217,1	2484	3700
145	5,82	3,04	195,9	2532	3700
145	7,33	2,41	155,4	2624	3700
145	8,38	2,11	136,1	2668	3700

IHR081

Mn_2 [Nm]	i	Pn_1 [kW]	n_2 [rpm]	Fr_1 [N]	Fr_2 [N]
113	1,30	10,60	878,8	653	2649
151	1,43	12,90	798,0	675	2708
196	1,93	12,37	590,4	1217	3027
238	2,54	11,41	448,5	1406	3272
264	3,25	9,90	350,8	1675	3563
264	3,72	8,64	306,3	1829	3748
272	4,00	8,29	285,0	1913	3856
272	4,67	7,10	244,3	2074	4000
282	5,54	6,20	205,8	2201	4000
290	6,08	5,81	187,4	2253	4000
298	7,50	4,84	152,0	2382	4000
298	8,44	4,30	135,0	2456	4000

IHR101

Mn_2 [Nm]	i	Pn_1 [kW]	n_2 [rpm]	Fr_1 [N]	Fr_2 [N]
210	1,29	19,80	881,9	1542	3251
282	1,41	24,40	808,4	1542	3309

IHR101

Mn_2 [Nm]	i	Pn_1 [kW]	n2 [rpm]	Fr1 [N]	Fr2 [N]
384	2,03	23,02	561,0	2283	3825
468	2,48	22,98	459,4	2315	4001
510	3,27	18,99	348,3	2638	4417
510	3,70	16,79	308,1	2791	4637
520	4,22	15,01	270,0	2936	4885
530	4,88	13,25	233,8	3059	5000
530	5,27	12,26	216,5	3126	5000
545	6,23	10,66	183,0	3233	5000
555	7,55	8,96	151,1	3351	5000
555	8,40	8,05	135,7	3414	5000

IHR121

Mn_2 [Nm]	i	Pn_1 [kW]	n2 [rpm]	Fr1 [N]	Fr2 [N]
189	1,23	18,70	926,2	647	4079
255	1,42	21,90	804,7	826	4247
412	1,81	27,80	631,1	1497	4670
496	2,00	30,20	570,0	1613	4816
680	2,48	33,41	459,7	1966	5192
680	2,95	28,04	385,9	2282	5555
700	3,14	27,14	362,7	2343	5668
725	3,58	24,68	318,5	2520	5947
725	4,12	21,45	276,9	2705	6000
740	4,80	18,78	237,5	2855	6000
750	5,21	17,53	218,6	2929	6000
765	6,25	14,92	182,4	3076	6000
850	7,70	13,45	148,1	3160	6000

IHA32

Mn ₂ [Nm]	i	Pn ₁ [kW]	n ₂ [rpm]	Fr1 [N]	Fr2 [N]
58	5,38	1,05	167,3	330	1270
58	6,52	0,86	138,1	409	1354
54	8,11	0,65	111,0	373	1457
65	10,94	0,58	82,3	441	1609
58	13,25	0,43	67,9	363	1716
58	16,49	0,34	54,6	398	1845
65	20,26	0,31	44,4	453	1976
61	24,55	0,24	36,7	386	2000
68	30,55	0,22	29,5	374	2000
77	35,44	0,21	25,4	480	2000
77	44,10	0,17	20,4	398	2000
68	48,75	0,14	18,5	398	2000
81	60,67	0,13	14,8	472	2000

IHA33

Mn ₂ [Nm]	i	Pn ₁ [kW]	n ₂ [rpm]	Fr1 [N]	Fr2 [N]
84	51,32	0,16	17,5	472	2000
85	59,65	0,14	15,1	472	2000
87	72,27	0,12	12,4	472	2000
84	89,94	0,09	10,0	472	2000
85	110,51	0,08	8,1	472	2000
88	133,88	0,07	6,7	472	2000
82	166,61	0,05	5,4	472	2000
85	193,30	0,04	4,7	472	2000
79	240,55	0,03	3,7	472	2000
92	279,07	0,03	3,2	472	2000
76	347,29	0,02	2,6	472	2000

IHA41

Mn ₂ [Nm]	i	Pn ₁ [kW]	n ₂ [rpm]	Fr1 [N]	Fr2 [N]
21	1,45	1,39	621,4	330	593
21	2,94	0,69	305,7	330	751
26	4,75	0,53	189,5	330	881
26	5,45	0,46	165,0	330	922
21	7,88	0,26	114,3	330	1042
17	10,83	0,15	83,1	330	1100

IHA42

Mn_2 [Nm]	i	Pn_1 [kW]	n2 [rpm]	Fr1 [N]	Fr2 [N]
101	5,38	1,82	167,3	330	2674
101	6,52	1,51	138,1	409	2851
94	8,11	1,13	111,0	369	3067
108	10,94	0,96	82,3	424	3388
101	13,25	0,74	67,9	381	3612
101	16,49	0,60	54,6	398	3885
108	20,26	0,52	44,4	432	4161
112	24,55	0,44	36,7	422	4300
120	30,55	0,38	29,5	359	4300
128	35,44	0,35	25,4	457	4300
120	44,10	0,26	20,4	371	4300
111	48,75	0,22	18,5	416	4300
120	60,67	0,19	14,8	428	4300

IHA43

Mn_2 [Nm]	i	Pn_1 [kW]	n2 [rpm]	Fr1 [N]	Fr2 [N]
129	51,32	0,25	17,5	427	4300
127	59,65	0,21	15,1	426	4300
127	72,27	0,17	12,4	409	4300
128	89,94	0,14	10,0	398	4300
127	110,51	0,11	8,1	403	4300
125	133,88	0,09	6,7	409	4300
128	166,61	0,08	5,4	398	4300
127	193,30	0,07	4,7	427	4300
132	240,55	0,05	3,7	398	4300
122	279,07	0,04	3,2	427	4300
133	347,29	0,04	2,6	398	4300

IHA51

Mn_2 [Nm]	i	Pn_1 [kW]	n2 [rpm]	Fr1 [N]	Fr2 [N]
34	1,45	2,26	621,4	330	1634
34	2,94	1,11	305,7	330	2069
43	4,75	0,87	189,5	330	2427
43	5,45	0,76	165,0	330	2542
34	7,88	0,42	114,3	330	2873
21	10,83	0,19	83,1	330	3000

IHA52

Mn ₂ [Nm]	i	Pn ₁ [kW]	n ₂ [rpm]	Fr1 [N]	Fr2 [N]
173	5,14	3,27	175,0	550	3293
173	6,22	2,70	144,6	682	3509
173	7,73	2,17	116,4	664	3773
216	9,64	2,18	93,3	827	4061
202	11,67	1,68	77,1	636	4327
202	14,50	1,35	62,1	664	4652
216	16,91	1,24	53,2	758	4897
208	20,46	0,99	44,0	659	5218
202	25,43	0,77	35,4	641	5610
216	29,89	0,70	30,1	752	5921
256	36,17	0,69	24,9	682	6000
238	44,95	0,51	20,0	620	6000
256	49,78	0,50	18,1	798	6000
246	61,87	0,39	14,6	642	6000

IHA53

Mn ₂ [Nm]	i	Pn ₁ [kW]	n ₂ [rpm]	Fr1 [N]	Fr2 [N]
256	49,80	0,51	18,1	330	6000
256	60,25	0,42	14,9	409	6000
254	74,88	0,34	12,0	398	6000
254	88,02	0,29	10,2	421	6000
256	111,61	0,23	8,1	390	6000
258	138,71	0,18	6,5	398	6000
258	163,05	0,16	5,5	421	6000
252	200,27	0,12	4,5	403	6000
256	235,41	0,11	3,8	421	6000
248	284,81	0,09	3,2	409	6000
252	353,98	0,07	2,5	398	6000

IHA61

Mn ₂ [Nm]	i	Pn ₁ [kW]	n ₂ [rpm]	Fr1 [N]	Fr2 [N]
77	1,33	5,56	675,0	550	2379
77	2,50	2,96	360,0	550	2933
94	4,38	2,06	205,3	550	3537
77	7,75	0,96	116,1	550	4277
60	10,67	0,54	84,4	550	4500

IHA62

Mn ₂ [Nm]	i	Pn ₁ [kW]	n ₂ [rpm]	Fr1 [N]	Fr2 [N]
274	5,14	5,18	175,0	550	4861
274	6,22	4,28	144,6	682	5179
274	7,73	3,44	116,4	664	5569
332	9,64	3,35	93,3	801	5994
318	11,67	2,65	77,1	652	6387
302	14,50	2,02	62,1	634	6867
360	16,91	2,07	53,2	842	7228
332	20,46	1,58	44,0	627	7702
310	25,43	1,18	35,4	621	8000
324	29,89	1,05	30,1	734	8000
400	36,17	1,07	24,9	712	8000
376	44,95	0,81	20,0	621	8000
316	49,78	0,62	18,1	626	8000
376	61,87	0,59	14,6	789	8000

IHA63

Mn ₂ [Nm]	i	Pn ₁ [kW]	n ₂ [rpm]	Fr1 [N]	Fr2 [N]
408	49,80	0,81	18,1	330	8000
408	60,25	0,67	14,9	409	8000
410	74,88	0,54	12,0	398	8000
408	88,02	0,46	10,2	421	8000
408	111,61	0,36	8,1	390	8000
410	138,71	0,29	6,5	398	8000
410	163,05	0,25	5,5	421	8000
406	200,27	0,20	4,5	403	8000
412	235,41	0,17	3,8	421	8000
404	284,81	0,14	3,2	409	8000
406	353,98	0,11	2,5	398	8000

IH032

Mn ₂ [Nm]	i	Pn ₁ [kW]	n ₂ [rpm]	Fr1 [N]	Fr2 [N]
69	4,70	1,43	191,7	665	3578
76	6,23	1,19	144,5	788	3925
90	7,76	1,13	115,9	815	4093
94	8,87	1,03	101,5	868	4285
101	10,14	0,97	88,7	900	4438
105	11,76	0,87	76,5	953	4685
123	13,72	0,87	65,6	951	4742
123	14,66	0,82	61,4	980	4889

IH032

Mn_2 [Nm]	i	Pn_1 [kW]	n_2 [rpm]	Fr1 [N]	Fr2 [N]
137	16,77	0,79	53,7	990	4980
145	18,20	0,77	49,5	1002	5066
145	19,90	0,71	45,2	1037	5285
145	22,68	0,62	39,7	1082	5500
145	23,83	0,59	37,8	1097	5500
145	26,39	0,53	34,1	1127	5500
146	29,70	0,48	30,3	1158	5500
171	32,89	0,51	27,4	1182	5500
171	37,92	0,44	23,7	1211	5500
171	41,40	0,40	21,7	1227	5500
171	47,25	0,35	19,1	1249	5500

IH033

Mn_2 [Nm]	i	Pn_1 [kW]	n_2 [rpm]	Fr1 [N]	Fr2 [N]
170	53,59	0,31	16,8	1267	5500
172	66,78	0,26	13,5	1294	5500
172	74,84	0,23	12,0	1306	5500
169	99,27	0,17	9,1	1330	5500
172	108,05	0,16	8,3	1336	5500
169	123,71	0,14	7,3	1345	5500
173	143,33	0,12	6,3	1353	5500
166	178,61	0,09	5,0	1363	5500
173	197,17	0,09	4,6	1367	5500
175	245,70	0,07	3,7	1374	5500

IH042

Mn_2 [Nm]	i	Pn_1 [kW]	n_2 [rpm]	Fr1 [N]	Fr2 [N]
116	5,46	2,06	164,8	384	4643
116	7,19	1,57	125,2	635	5221
152	8,91	1,66	101,0	588	5278
173	10,31	1,63	87,3	599	5371
181	11,80	1,49	76,3	673	5626
181	13,57	1,30	66,3	772	5998
181	15,96	1,10	56,4	870	6452
181	19,00	0,93	47,4	959	6600
181	21,00	0,84	42,9	1004	6600
188	23,15	0,79	38,9	1028	6600
188	26,04	0,70	34,6	1073	6600
202	27,50	0,71	32,7	1065	6600

IH042

Mn_2 [Nm]	i	Pn_1 [kW]	n_2 [rpm]	Fr_1 [N]	Fr_2 [N]
238	30,45	0,76	29,6	1101	6600
238	34,10	0,68	26,4	1136	6600
238	37,76	0,61	23,8	1164	6600
238	43,75	0,53	20,6	1200	6600
238	47,53	0,49	18,9	1218	6600
238	54,25	0,43	16,6	1244	6600

IH043

Mn_2 [Nm]	i	Pn_1 [kW]	n_2 [rpm]	Fr_1 [N]	Fr_2 [N]
256	61,83	0,41	14,6	1256	6600
256	76,67	0,33	11,7	1289	6600
256	87,05	0,29	10,3	1306	6600
256	114,55	0,22	7,9	1335	6600
256	125,69	0,20	7,2	1343	6600
256	142,04	0,18	6,3	1353	6600
256	165,38	0,15	5,4	1364	6600
256	205,07	0,12	4,4	1376	6600
256	227,50	0,11	4,0	1381	6600
256	282,10	0,09	3,2	1391	6600

IH052

Mn_2 [Nm]	i	Pn_1 [kW]	n_2 [rpm]	Fr_1 [N]	Fr_2 [N]
188	5,73	3,19	157,1	202	5759
208	6,89	2,93	130,6	290	6032
244	8,53	2,78	105,5	348	6274
266	9,56	2,70	94,1	379	6401
280	11,51	2,36	78,2	506	6834
310	14,24	2,12	63,2	603	7256
324	16,59	1,90	54,2	684	7654
332	18,00	1,79	50,0	725	7881
332	19,97	1,62	45,1	792	8000
338	21,67	1,52	41,5	827	8000
338	24,71	1,33	36,4	897	8000
354	26,18	1,31	34,4	905	8000
354	28,44	1,21	31,6	945	8000
418	31,52	1,29	28,6	989	8000
418	33,00	1,23	27,3	1007	8000
418	38,98	1,04	23,1	1067	8000
418	45,36	0,90	19,8	1114	8000

IH052

Mn_2 [Nm]	i	Pn_1 [kW]	n_2 [rpm]	Fr_1 [N]	Fr_2 [N]
418	49,13	0,83	18,3	1136	8000
418	56,11	0,72	16,0	1168	8000

IH053

Mn_2 [Nm]	i	Pn_1 [kW]	n_2 [rpm]	Fr_1 [N]	Fr_2 [N]
428	58,81	0,72	15,3	1174	8000
426	72,75	0,58	12,4	1217	8000
426	90,51	0,47	9,9	1253	8000
428	108,95	0,39	8,3	1278	8000
428	134,76	0,32	6,7	1301	8000
430	157,29	0,27	5,7	1315	8000
426	194,56	0,22	4,6	1331	8000
426	216,38	0,20	4,2	1338	8000
424	267,65	0,16	3,4	1349	8000

IH062

Mn_2 [Nm]	i	Pn_1 [kW]	n_2 [rpm]	Fr_1 [N]	Fr_2 [N]
360	5,38	6,51	167,4	753	9322
396	5,93	6,49	151,7	761	9432
396	7,39	5,21	121,8	1171	10402
432	8,50	4,94	105,9	1257	10753
434	9,39	4,49	95,9	1406	11238
470	11,69	3,91	77,0	1593	12000
505	12,67	3,88	71,0	1601	12000
505	14,75	3,33	61,0	1776	12000
575	16,29	3,43	55,3	1739	12000
600	17,67	3,30	50,9	1787	12000
610	20,28	2,92	44,4	1901	12000
610	23,27	2,55	38,7	2022	12000
610	25,70	2,31	35,0	2099	12000
576	29,33	1,91	30,7	2229	12000
725	32,00	2,20	28,1	2245	12000
680	36,99	1,79	24,3	2356	12000
725	40,33	1,75	22,3	2369	12000
725	46,06	1,53	19,5	2427	12000

IH063

Mn ₂ [Nm]	i	Pn ₁ [kW]	n ₂ [rpm]	Fr1 [N]	Fr2 [N]
725	49,45	1,46	18,2	2456	12000
725	54,61	1,32	16,5	2492	12000
725	68,00	1,06	13,2	2561	12000
720	85,82	0,83	10,5	2619	12000
725	94,76	0,76	9,5	2640	12000
720	118,00	0,61	7,6	2680	12000
725	135,40	0,53	6,7	2701	12000
725	149,51	0,48	6,0	2714	12000
725	170,67	0,42	5,3	2730	12000
720	186,18	0,38	4,8	2739	12000
730	215,21	0,34	4,2	2753	12000
720	234,67	0,30	3,8	2760	12000
715	268,00	0,26	3,4	2770	12000

IH082

Mn ₂ [Nm]	i	Pn ₁ [kW]	n ₂ [rpm]	Fr1 [N]	Fr2 [N]
505	5,39	9,11	167,0	706	11651
505	5,95	8,25	151,4	922	12152
575	7,39	7,56	121,7	1091	12841
575	8,02	6,97	112,2	1241	13300
650	8,85	7,14	101,7	1206	13391
795	11,01	7,02	81,8	1237	13766
1010	13,50	7,27	66,7	1170	13667
1080	14,90	7,05	60,4	1223	13866
1080	16,62	6,32	54,2	1408	14648
1080	18,53	5,67	48,6	1573	15455
1155	19,38	5,79	46,4	1545	15320
1155	21,39	5,25	42,1	1682	16087
1155	22,80	4,92	39,5	1764	16598
1155	26,60	4,22	33,8	1942	17879
1155	27,88	4,03	32,3	1991	18000
1365	31,15	4,26	28,9	2098	18000
1365	34,38	3,86	26,2	2183	18000
1365	38,70	3,43	23,2	2275	18000
1365	42,75	3,10	21,1	2345	18000
1365	48,13	2,76	18,7	2419	18000

IH083

Mn ₂ [Nm]	i	Pn ₁ [kW]	n ₂ [rpm]	Fr1 [N]	Fr2 [N]
1365	56,53	2,40	15,9	2506	18000
1535	71,48	2,13	12,6	2562	18000
1535	78,87	1,93	11,4	2604	18000
1535	85,56	1,78	10,5	2635	18000
1535	98,09	1,55	9,2	2683	18000
1535	112,78	1,35	8,0	2725	18000
1540	124,44	1,23	7,2	2752	18000
1530	142,15	1,07	6,3	2784	18000
1530	154,76	0,98	5,8	2802	18000
1535	162,35	0,94	5,5	2812	18000
1540	179,13	0,85	5,0	2830	18000
1535	195,07	0,78	4,6	2845	18000
1535	222,78	0,68	4,0	2865	18000

IH102

Mn ₂ [Nm]	i	Pn ₁ [kW]	n ₂ [rpm]	Fr1 [N]	Fr2 [N]
1300	5,26	24,01	171,0	1613	12767
1445	6,36	22,10	141,6	1811	13264
1660	7,05	22,88	127,6	1727	12817
1805	8,27	21,20	108,8	1902	13225
2020	9,99	19,65	90,1	2061	13535
2170	11,09	19,03	81,2	2130	13608
2240	13,32	16,34	67,5	2405	14826
2310	16,09	13,95	55,9	2650	16191
2310	17,85	12,58	50,4	2792	17209
2310	19,85	11,31	45,3	2923	18287
2310	21,44	10,47	42,0	3010	19096
2385	23,97	9,67	37,5	3094	19902
2385	25,89	8,95	34,8	3168	20764
2385	28,73	8,07	31,3	3259	21958
2730	30,72	8,64	29,3	3337	22000
2730	34,20	7,76	26,3	3413	22000
2390	38,45	6,04	23,4	3564	22000
2820	41,30	6,64	21,8	3512	22000
2820	45,82	5,98	19,6	3569	22000
2820	51,52	5,32	17,5	3627	22000

IH103

Mn ₂ [Nm]	i	Pn ₁ [kW]	n ₂ [rpm]	Fr1 [N]	Fr2 [N]
2990	55,47	5,35	16,2	3634	22000
2985	69,69	4,25	12,9	3727	22000
2990	79,82	3,72	11,3	3774	22000
2990	84,16	3,53	10,7	3790	22000
2990	93,36	3,18	9,6	3820	22000
2985	100,07	2,96	9,0	3838	22000
2990	120,84	2,46	7,5	3882	22000
2985	134,06	2,21	6,7	3902	22000
2990	143,42	2,07	6,3	3915	22000
2985	160,82	1,84	5,6	3934	22000
2985	181,07	1,64	5,0	3951	22000
2990	194,21	1,53	4,6	3961	22000
2985	215,45	1,38	4,2	3974	22000
2610	242,59	1,07	3,7	3984	22000

IH122

Mn ₂ [Nm]	i	Pn ₁ [kW]	n ₂ [rpm]	Fr1 [N]	Fr2 [N]
2165	5,27	39,89	170,6	616	18507
2315	5,78	38,96	155,8	703	18709
2589	7,05	35,70	127,7	964	19385
2670	7,74	33,52	116,2	1161	20049
2745	8,48	31,48	106,2	1338	20710
2890	10,35	27,15	87,0	1709	22339
3180	12,66	24,41	71,1	1944	23484
3325	13,86	23,31	64,9	2038	23985
3470	16,92	19,93	53,2	2327	26025
3615	19,32	18,19	46,6	2476	27258
3615	20,57	17,08	43,8	2570	28191
3610	22,52	15,58	40,0	2697	29575
3615	24,47	14,36	36,8	2803	30000
3615	27,49	12,78	32,7	2938	30000
3610	29,86	11,75	30,1	3024	30000
4270	33,00	12,58	27,3	3120	30000
4270	36,13	11,49	24,9	3199	30000
4270	44,10	9,41	20,4	3349	30000

IH123

Mn ₂ [Nm]	i	Pn ₁ [kW]	n ₂ [rpm]	Fr1 [N]	Fr2 [N]
4270	45,77	9,26	19,7	3374	30000

IH123

Mn ₂ [Nm]	i	Pn ₁ [kW]	n ₂ [rpm]	Fr1 [N]	Fr2 [N]
4270	55,87	7,59	16,1	3492	30000
4270	67,32	6,30	13,4	3583	30000
4270	73,71	5,75	12,2	3622	30000
4270	83,34	5,09	10,8	3669	30000
4270	89,97	4,71	10,0	3696	30000
4275	100,29	4,23	9,0	3730	30000
4270	108,34	3,91	8,3	3752	30000
4270	118,62	3,57	7,6	3776	30000
4270	128,18	3,31	7,0	3795	30000
4275	144,79	2,93	6,2	3822	30000
4265	155,22	2,73	5,8	3836	30000
4270	172,80	2,45	5,2	3855	30000
4270	189,19	2,24	4,8	3871	30000
4270	207,43	2,04	4,3	3884	30000
4275	230,92	1,84	3,9	3899	30000

IH142

Mn ₂ [Nm]	i	Pn ₁ [kW]	n ₂ [rpm]	Fr1 [N]	Fr2 [N]
3202	5,27	59,00	170,6	4831	23594
3492	6,36	53,40	141,6	5490	25090
3610	7,04	49,82	127,8	5889	26187
3830	7,84	47,46	114,8	6111	26774
4700	9,45	48,34	95,2	6033	25788
5200	10,47	48,26	85,9	6035	25199
5275	13,07	39,22	68,8	6877	28552
5640	15,75	34,81	57,1	7289	30282
5710	17,45	31,80	51,6	7567	31876
5780	20,04	28,03	44,9	7916	34236
5780	24,15	23,26	37,3	8359	38042
5780	26,76	20,99	33,6	8570	40244
6835	32,24	20,60	27,9	8901	44431
6835	38,85	17,10	23,2	9176	48891
6835	43,05	15,43	20,9	9308	51470

IH143

Mn ₂ [Nm]	i	Pn ₁ [kW]	n ₂ [rpm]	Fr1 [N]	Fr2 [N]
6835	48,35	14,03	18,6	9440	54488
6835	53,53	12,68	16,8	9545	55000
6835	59,22	11,46	15,2	9638	55000

IH143

Mn ₂ [Nm]	i	Pn ₁ [kW]	n ₂ [rpm]	Fr1 [N]	Fr2 [N]
6835	62,99	10,77	14,3	9691	55000
6835	71,35	9,51	12,6	9788	55000
6835	79,07	8,58	11,4	9860	55000
6830	86,43	7,84	10,4	9916	55000
6835	96,21	7,05	9,3	9977	55000
6835	104,51	6,49	8,6	10020	55000
6830	115,92	5,85	7,8	10070	55000
6835	128,47	5,28	7,0	10114	55000
6835	139,55	4,86	6,5	10146	55000
6830	154,33	4,39	5,8	10182	55000
6835	185,96	3,65	4,8	10239	55000
6830	206,08	3,29	4,4	10267	55000

IHR041

Mn ₂ [Nm]	i	Pn ₁ [kW]	n ₂ [rpm]	Fr1 [N]	Fr2 [N]
21	1,44	1,41	626,1	930	737
21	2,00	1,01	450,0	1054	838
26	2,55	0,98	353,6	1068	891
26	2,71	0,92	331,6	1087	914
34	3,11	1,05	289,8	1050	914
38	3,59	1,02	250,8	1087	965
38	4,20	0,87	214,3	1128	1000
38	5,00	0,73	180,0	1167	1000
43	5,50	0,75	163,6	1164	1000
43	6,09	0,68	147,8	1184	1000
43	7,67	0,54	117,4	1223	1000
47	8,75	0,52	102,9	1228	1000

IHR051

Mn ₂ [Nm]	i	Pn ₁ [kW]	n ₂ [rpm]	Fr1 [N]	Fr2 [N]
34	1,27	2,57	707,1	723	1849
51	1,42	3,46	634,1	525	1801
51	2,13	2,31	423,5	813	2120
60	2,57	2,24	350,0	840	2223
68	3,17	2,07	284,2	884	2353
77	3,69	2,01	244,1	930	2472
77	4,00	1,85	225,0	966	2500
81	4,77	1,63	188,7	1015	2500
85	5,25	1,56	171,4	1032	2500

IHR051

Mn_2 [Nm]	i	Pn_1 [kW]	n2 [rpm]	Fr1 [N]	Fr2 [N]
85	5,82	1,41	154,7	1067	2500
85	7,33	1,11	122,7	1135	2500
86	8,38	0,99	107,5	1167	2500

IHR061

Mn_2 [Nm]	i	Pn_1 [kW]	n2 [rpm]	Fr1 [N]	Fr2 [N]
68	1,34	4,87	669,8	1819	2682
103	2,13	4,66	423,5	2025	3068
102	2,57	3,82	350,0	2129	3264
111	3,17	3,37	284,2	2289	3540
128	3,69	3,34	244,1	2343	3700
128	4,00	3,08	225,0	2393	3700
137	4,77	2,76	188,7	2454	3700
145	5,25	2,66	171,4	2472	3700
145	5,82	2,40	154,7	2522	3700
145	7,33	1,90	122,7	2615	3700
145	8,38	1,67	107,5	2660	3700

IHR081

Mn_2 [Nm]	i	Pn_1 [kW]	n2 [rpm]	Fr1 [N]	Fr2 [N]
143	1,30	10,60	693,8	594	2894
188	1,43	12,66	630,0	617	2960
196	1,93	9,76	466,1	1173	3306
238	2,54	9,01	354,1	1366	3577
264	3,25	7,81	276,9	1642	3894
264	3,72	6,82	241,8	1800	4000
272	4,00	6,54	225,0	1886	4000
272	4,67	5,61	192,9	2051	4000
282	5,54	4,90	162,5	2180	4000
290	6,08	4,59	147,9	2233	4000
298	7,50	3,82	120,0	2366	4000
298	8,44	3,39	106,6	2442	4000

IHR101

Mn_2 [Nm]	i	Pn_1 [kW]	n2 [rpm]	Fr1 [N]	Fr2 [N]
266	1,29	19,80	696,2	1483	3554
358	1,41	24,40	638,2	1483	3619

IHR101

Mn_2 [Nm]	i	Pn_1 [kW]	n_2 [rpm]	Fr_1 [N]	Fr_2 [N]
384	2,03	18,18	442,9	2242	4178
468	2,48	18,14	362,7	2275	4376
510	3,27	14,99	275,0	2606	4829
510	3,70	13,26	243,2	2762	5000
520	4,22	11,85	213,2	2911	5000
530	4,88	10,46	184,6	3037	5000
530	5,27	9,68	170,9	3106	5000
545	6,23	8,41	144,4	3215	5000
555	7,55	7,08	119,3	3336	5000
555	8,40	6,36	107,1	3400	5000

IHR121

Mn_2 [Nm]	i	Pn_1 [kW]	n_2 [rpm]	Fr_1 [N]	Fr_2 [N]
239	1,23	18,70	731,2	567	4454
323	1,42	21,90	635,3	751	4639
522	1,81	27,80	498,2	1437	5096
628	2,00	30,20	450,0	1557	5257
680	2,48	26,38	362,9	1918	5667
680	2,95	22,14	304,6	2242	6000
700	3,14	21,42	286,4	2304	6000
725	3,58	19,49	251,5	2486	6000
725	4,12	16,94	218,6	2675	6000
740	4,80	14,83	187,5	2828	6000
750	5,21	13,84	172,6	2905	6000
765	6,25	11,78	144,0	3055	6000
850	7,70	10,62	116,9	3141	6000

IHA32

Mn ₂ [Nm]	i	Pn ₁ [kW]	n ₂ [rpm]	Fr1 [N]	Fr2 [N]
58	5,38	0,81	130,1	330	1381
58	6,52	0,67	107,4	409	1473
54	8,11	0,50	86,3	373	1584
65	10,94	0,45	64,0	441	1750
58	13,25	0,33	52,8	363	1865
58	16,49	0,26	42,5	398	2000
65	20,26	0,24	34,5	453	2000
61	24,55	0,19	28,5	386	2000
68	30,55	0,17	22,9	374	2000
77	35,44	0,16	19,8	480	2000
77	44,10	0,13	15,9	398	2000
68	48,75	0,10	14,4	398	2000
81	60,67	0,10	11,5	472	2000

IHA33

Mn ₂ [Nm]	i	Pn ₁ [kW]	n ₂ [rpm]	Fr1 [N]	Fr2 [N]
84	51,32	0,13	13,6	472	2000
85	59,65	0,11	11,7	472	2000
87	72,27	0,09	9,7	472	2000
84	89,94	0,07	7,8	472	2000
85	110,51	0,06	6,3	472	2000
88	133,88	0,05	5,2	472	2000
82	166,61	0,04	4,2	472	2000
85	193,30	0,03	3,6	472	2000
79	240,55	0,03	2,9	472	2000
92	279,07	0,03	2,5	472	2000
76	347,29	0,02	2,0	472	2000

IHA41

Mn ₂ [Nm]	i	Pn ₁ [kW]	n ₂ [rpm]	Fr1 [N]	Fr2 [N]
21	1,45	1,08	483,3	330	645
21	2,94	0,53	237,7	330	817
26	4,75	0,41	147,4	330	958
26	5,45	0,35	128,3	330	1003
21	7,88	0,20	88,9	330	1100
17	10,83	0,12	64,6	330	1100

IHA42

Mn_2 [Nm]	i	Pn_1 [kW]	n2 [rpm]	Fr1 [N]	Fr2 [N]
101	5,38	1,41	130,1	330	2908
101	6,52	1,17	107,4	409	3100
94	8,11	0,87	86,3	369	3334
108	10,94	0,74	64,0	424	3684
101	13,25	0,57	52,8	381	3927
101	16,49	0,46	42,5	398	4224
108	20,26	0,40	34,5	432	4300
112	24,55	0,34	28,5	422	4300
120	30,55	0,30	22,9	359	4300
128	35,44	0,27	19,8	457	4300
120	44,10	0,20	15,9	371	4300
111	48,75	0,17	14,4	416	4300
120	60,67	0,15	11,5	428	4300

IHA43

Mn_2 [Nm]	i	Pn_1 [kW]	n2 [rpm]	Fr1 [N]	Fr2 [N]
129	51,32	0,19	13,6	427	4300
127	59,65	0,16	11,7	426	4300
127	72,27	0,13	9,7	409	4300
128	89,94	0,11	7,8	398	4300
127	110,51	0,09	6,3	403	4300
125	133,88	0,07	5,2	409	4300
128	166,61	0,06	4,2	398	4300
127	193,30	0,05	3,6	427	4300
132	240,55	0,04	2,9	398	4300
122	279,07	0,03	2,5	427	4300
133	347,29	0,03	2,0	398	4300

IHA51

Mn_2 [Nm]	i	Pn_1 [kW]	n2 [rpm]	Fr1 [N]	Fr2 [N]
34	1,45	1,75	483,3	330	1776
34	2,94	0,86	237,7	330	2250
43	4,75	0,67	147,4	330	2639
43	5,45	0,59	128,3	330	2764
34	7,88	0,32	88,9	330	3000
21	10,83	0,14	64,6	330	3000

IHA52

Mn ₂ [Nm]	i	Pn ₁ [kW]	n ₂ [rpm]	Fr1 [N]	Fr2 [N]
173	5,14	2,53	136,1	550	3581
173	6,22	2,09	112,5	682	3816
173	7,73	1,68	90,5	664	4103
216	9,64	1,69	72,6	827	4416
202	11,67	1,30	60,0	636	4705
202	14,50	1,05	48,3	664	5059
216	16,91	0,96	41,4	758	5325
208	20,46	0,76	34,2	659	5674
202	25,43	0,60	27,5	641	6000
216	29,89	0,54	23,4	752	6000
256	36,17	0,53	19,4	682	6000
238	44,95	0,40	15,6	620	6000
256	49,78	0,39	14,1	798	6000
246	61,87	0,30	11,3	642	6000

IHA53

Mn ₂ [Nm]	i	Pn ₁ [kW]	n ₂ [rpm]	Fr1 [N]	Fr2 [N]
256	49,80	0,39	14,1	330	6000
256	60,25	0,33	11,6	409	6000
254	74,88	0,26	9,3	398	6000
254	88,02	0,22	8,0	421	6000
256	111,61	0,18	6,3	390	6000
258	138,71	0,14	5,0	398	6000
258	163,05	0,12	4,3	421	6000
252	200,27	0,10	3,5	403	6000
256	235,41	0,08	3,0	421	6000
248	284,81	0,07	2,5	409	6000
252	353,98	0,05	2,0	398	6000

IHA61

Mn ₂ [Nm]	i	Pn ₁ [kW]	n ₂ [rpm]	Fr1 [N]	Fr2 [N]
77	1,33	4,30	525,0	550	2586
77	2,50	2,29	280,0	550	3189
94	4,38	1,60	159,7	550	3846
77	7,75	0,74	90,3	550	4500
60	10,67	0,42	65,6	550	4500

IHA62

Mn ₂ [Nm]	i	Pn ₁ [kW]	n ₂ [rpm]	Fr1 [N]	Fr2 [N]
274	5,14	4,01	136,1	550	5285
274	6,22	3,31	112,5	682	5632
274	7,73	2,67	90,5	664	6055
332	9,64	2,59	72,6	801	6518
318	11,67	2,05	60,0	652	6945
302	14,50	1,57	48,3	634	7467
360	16,91	1,60	41,4	842	7860
332	20,46	1,22	34,2	627	8000
310	25,43	0,92	27,5	621	8000
324	29,89	0,82	23,4	734	8000
400	36,17	0,83	19,4	712	8000
376	44,95	0,63	15,6	621	8000
316	49,78	0,48	14,1	626	8000
376	61,87	0,46	11,3	789	8000

IHA63

Mn ₂ [Nm]	i	Pn ₁ [kW]	n ₂ [rpm]	Fr1 [N]	Fr2 [N]
408	49,80	0,63	14,1	330	8000
408	60,25	0,52	11,6	409	8000
410	74,88	0,42	9,3	398	8000
408	88,02	0,36	8,0	421	8000
408	111,61	0,28	6,3	390	8000
410	138,71	0,23	5,0	398	8000
410	163,05	0,19	4,3	421	8000
406	200,27	0,16	3,5	403	8000
412	235,41	0,13	3,0	421	8000
404	284,81	0,11	2,5	409	8000
406	353,98	0,09	2,0	398	8000

IH032

Mn ₂ [Nm]	i	Pn ₁ [kW]	n ₂ [rpm]	Fr1 [N]	Fr2 [N]
69	4,70	1,11	149,1	656	3969
76	6,23	0,92	112,4	781	4355
90	7,76	0,87	90,2	808	4553
94	8,87	0,80	79,0	862	4767
101	10,14	0,75	69,0	894	4941
105	11,76	0,67	59,5	948	5214
123	13,72	0,67	51,0	946	5297
123	14,66	0,63	47,8	975	5457

IH032

Mn ₂ [Nm]	i	Pn ₁ [kW]	n ₂ [rpm]	Fr1 [N]	Fr2 [N]
137	16,77	0,61	41,8	985	5500
145	18,20	0,60	38,5	998	5500
145	19,90	0,55	35,2	1032	5500
145	22,68	0,48	30,9	1078	5500
145	23,83	0,46	29,4	1094	5500
145	26,39	0,41	26,5	1124	5500
146	29,70	0,37	23,6	1155	5500
171	32,89	0,39	21,3	1179	5500
171	37,92	0,34	18,5	1209	5500
171	41,40	0,31	16,9	1225	5500
171	47,25	0,27	14,8	1247	5500

IH033

Mn ₂ [Nm]	i	Pn ₁ [kW]	n ₂ [rpm]	Fr1 [N]	Fr2 [N]
170	53,59	0,24	13,1	1266	5500
172	66,78	0,20	10,5	1293	5500
172	74,84	0,18	9,3	1305	5500
169	99,27	0,13	7,0	1329	5500
172	108,05	0,12	6,5	1335	5500
169	123,71	0,10	5,7	1344	5500
173	143,33	0,09	4,9	1352	5500
166	178,61	0,07	3,9	1362	5500
173	197,17	0,07	3,5	1366	5500
175	245,70	0,05	2,9	1374	5500

IH042

Mn ₂ [Nm]	i	Pn ₁ [kW]	n ₂ [rpm]	Fr1 [N]	Fr2 [N]
116	5,46	1,60	128,2	372	5154
116	7,19	1,21	97,4	625	5783
152	8,91	1,28	78,5	578	5877
173	10,31	1,26	67,9	589	5998
181	11,80	1,15	59,3	664	6282
181	13,57	1,00	51,6	764	6600
181	15,96	0,85	43,9	863	6600
181	19,00	0,72	36,8	954	6600
181	21,00	0,65	33,3	999	6600
188	23,15	0,61	30,2	1023	6600
188	26,04	0,54	26,9	1068	6600
202	27,50	0,55	25,4	1061	6600

IH042

Mn ₂ [Nm]	i	Pn ₁ [kW]	n ₂ [rpm]	Fr1 [N]	Fr2 [N]
238	30,45	0,59	23,0	1097	6600
238	34,10	0,53	20,5	1132	6600
238	37,76	0,47	18,5	1161	6600
238	43,75	0,41	16,0	1198	6600
238	47,53	0,38	14,7	1216	6600
238	54,25	0,33	12,9	1242	6600

IH043

Mn ₂ [Nm]	i	Pn ₁ [kW]	n ₂ [rpm]	Fr1 [N]	Fr2 [N]
256	61,83	0,32	11,3	1253	6600
256	76,67	0,26	9,1	1287	6600
256	87,05	0,23	8,0	1304	6600
256	114,55	0,17	6,1	1334	6600
256	125,69	0,16	5,6	1342	6600
256	142,04	0,14	4,9	1352	6600
256	165,38	0,12	4,2	1363	6600
256	205,07	0,10	3,4	1376	6600
256	227,50	0,09	3,1	1381	6600
256	282,10	0,07	2,5	1390	6600

IH052

Mn ₂ [Nm]	i	Pn ₁ [kW]	n ₂ [rpm]	Fr1 [N]	Fr2 [N]
188	5,73	2,47	122,2	188	6400
208	6,89	2,27	101,5	277	6713
244	8,53	2,15	82,1	336	7002
266	9,56	2,09	73,2	367	7156
280	11,51	1,83	60,8	495	7637
310	14,24	1,64	49,2	593	8000
324	16,59	1,47	42,2	675	8000
332	18,00	1,39	38,9	717	8000
332	19,97	1,25	35,0	784	8000
338	21,67	1,17	32,3	820	8000
338	24,71	1,03	28,3	891	8000
354	26,18	1,02	26,7	900	8000
354	28,44	0,94	24,6	939	8000
418	31,52	1,00	22,2	984	8000
418	33,00	0,95	21,2	1003	8000
418	38,98	0,81	18,0	1063	8000
418	45,36	0,69	15,4	1111	8000

IH052

Mn_2 [Nm]	i	Pn_1 [kW]	n_2 [rpm]	Fr_1 [N]	Fr_2 [N]
418	49,13	0,64	14,2	1133	8000
418	56,11	0,56	12,5	1166	8000

IH053

Mn_2 [Nm]	i	Pn_1 [kW]	n_2 [rpm]	Fr_1 [N]	Fr_2 [N]
428	58,81	0,56	11,9	1172	8000
426	72,75	0,45	9,6	1215	8000
426	90,51	0,36	7,7	1251	8000
428	108,95	0,30	6,4	1276	8000
428	134,76	0,24	5,2	1300	8000
430	157,29	0,21	4,5	1314	8000
426	194,56	0,17	3,6	1330	8000
426	216,38	0,15	3,2	1337	8000
424	267,65	0,12	2,6	1349	8000

IH062

Mn_2 [Nm]	i	Pn_1 [kW]	n_2 [rpm]	Fr_1 [N]	Fr_2 [N]
360	5,38	5,04	130,2	728	10367
396	5,93	5,02	118,0	736	10510
396	7,39	4,03	94,7	1151	11565
432	8,50	3,82	82,3	1238	11970
434	9,39	3,48	74,6	1389	12000
470	11,69	3,03	59,9	1578	12000
505	12,67	3,00	55,3	1586	12000
505	14,75	2,58	47,5	1763	12000
575	16,29	2,66	43,0	1726	12000
600	17,67	2,55	39,6	1774	12000
610	20,28	2,26	34,5	1890	12000
610	23,27	1,97	30,1	2012	12000
610	25,70	1,79	27,2	2090	12000
576	29,33	1,48	23,9	2222	12000
725	32,00	1,70	21,9	2238	12000
680	36,99	1,38	18,9	2350	12000
725	40,33	1,35	17,4	2363	12000
725	46,06	1,18	15,2	2422	12000

IH063

Mn ₂ [Nm]	i	Pn ₁ [kW]	n ₂ [rpm]	Fr1 [N]	Fr2 [N]
725	49,45	1,13	14,2	2451	12000
725	54,61	1,02	12,8	2488	12000
725	68,00	0,82	10,3	2558	12000
720	85,82	0,64	8,2	2617	12000
725	94,76	0,59	7,4	2638	12000
720	118,00	0,47	5,9	2678	12000
725	135,40	0,41	5,2	2699	12000
725	149,51	0,37	4,7	2712	12000
725	170,67	0,33	4,1	2728	12000
720	186,18	0,30	3,8	2738	12000
730	215,21	0,26	3,2	2752	12000
720	234,67	0,24	3,0	2759	12000
715	268,00	0,20	2,6	2770	12000

IH082

Mn ₂ [Nm]	i	Pn ₁ [kW]	n ₂ [rpm]	Fr1 [N]	Fr2 [N]
505	5,39	7,05	129,9	679	12923
505	5,95	6,39	117,7	897	13467
575	7,39	5,85	94,7	1068	14253
575	8,02	5,39	87,3	1219	14752
650	8,85	5,52	79,1	1184	14887
795	11,01	5,43	63,6	1216	15367
1010	13,50	5,63	51,9	1148	15368
1080	14,90	5,45	47,0	1202	15622
1080	16,62	4,89	42,1	1389	16471
1080	18,53	4,39	37,8	1556	17349
1155	19,38	4,48	36,1	1528	17238
1155	21,39	4,06	32,7	1667	18000
1155	22,80	3,81	30,7	1750	18000
1155	26,60	3,27	26,3	1929	18000
1155	27,88	3,12	25,1	1979	18000
1365	31,15	3,30	22,5	2087	18000
1365	34,38	2,99	20,4	2173	18000
1365	38,70	2,65	18,1	2267	18000
1365	42,75	2,40	16,4	2337	18000
1365	48,13	2,13	14,5	2412	18000

IH083

Mn ₂ [Nm]	i	Pn ₁ [kW]	n ₂ [rpm]	Fr1 [N]	Fr2 [N]
1365	56,53	1,86	12,4	2500	18000
1535	71,48	1,65	9,8	2556	18000
1535	78,87	1,50	8,9	2599	18000
1535	85,56	1,38	8,2	2631	18000
1535	98,09	1,20	7,1	2679	18000
1535	112,78	1,05	6,2	2722	18000
1540	124,44	0,95	5,6	2749	18000
1530	142,15	0,83	4,9	2781	18000
1530	154,76	0,76	4,5	2799	18000
1535	162,35	0,73	4,3	2809	18000
1540	179,13	0,66	3,9	2828	18000
1535	195,07	0,60	3,6	2843	18000
1535	222,78	0,53	3,1	2863	18000

IH102

Mn ₂ [Nm]	i	Pn ₁ [kW]	n ₂ [rpm]	Fr1 [N]	Fr2 [N]
1300	5,26	18,58	133,0	1583	14423
1445	6,36	17,10	110,1	1784	15024
1660	7,05	17,71	99,3	1699	14628
1805	8,27	16,41	84,6	1876	15132
2020	9,99	15,21	70,1	2036	15559
2170	11,09	14,73	63,1	2107	15698
2240	13,32	12,65	52,5	2385	17053
2310	16,09	10,80	43,5	2633	18567
2310	17,85	9,73	39,2	2777	19675
2310	19,85	8,75	35,3	2909	20846
2310	21,44	8,10	32,6	2997	21727
2385	23,97	7,49	29,2	3082	22000
2385	25,89	6,93	27,0	3157	22000
2385	28,73	6,25	24,4	3249	22000
2730	30,72	6,68	22,8	3328	22000
2730	34,20	6,00	20,5	3405	22000
2390	38,45	4,68	18,2	3557	22000
2820	41,30	5,14	16,9	3505	22000
2820	45,82	4,63	15,3	3563	22000
2820	51,52	4,12	13,6	3622	22000

IH103

Mn ₂ [Nm]	i	Pn ₁ [kW]	n ₂ [rpm]	Fr1 [N]	Fr2 [N]
2990	55,47	4,14	12,6	3629	22000
2985	69,69	3,29	10,0	3723	22000
2990	79,82	2,88	8,8	3770	22000
2990	84,16	2,73	8,3	3786	22000
2990	93,36	2,46	7,5	3817	22000
2985	100,07	2,29	7,0	3835	22000
2990	120,84	1,90	5,8	3879	22000
2985	134,06	1,71	5,2	3900	22000
2990	143,42	1,60	4,9	3912	22000
2985	160,82	1,43	4,3	3932	22000
2985	181,07	1,27	3,9	3950	22000
2990	194,21	1,18	3,6	3959	22000
2985	215,45	1,06	3,2	3972	22000
2610	242,59	0,83	2,9	3983	22000

IH122

Mn ₂ [Nm]	i	Pn ₁ [kW]	n ₂ [rpm]	Fr1 [N]	Fr2 [N]
2165	5,27	30,88	132,7	575	20890
2315	5,78	30,15	121,2	664	21161
2600	7,05	27,75	99,3	927	21998
2670	7,74	25,94	90,4	1127	22745
2745	8,48	24,36	82,6	1306	23489
2890	10,35	21,01	67,7	1681	25312
3180	12,66	18,89	55,3	1919	26660
3325	13,86	18,04	50,5	2014	27255
3470	16,92	15,43	41,4	2306	29524
3615	19,32	14,07	36,2	2457	30000
3615	20,57	13,22	34,0	2553	30000
3610	22,52	12,06	31,1	2681	30000
3615	24,47	11,11	28,6	2788	30000
3615	27,49	9,89	25,5	2925	30000
3610	29,86	9,09	23,4	3012	30000
4270	33,00	9,73	21,2	3109	30000
4270	36,13	8,89	19,4	3189	30000
4270	44,10	7,28	15,9	3341	30000

IH123

Mn ₂ [Nm]	i	Pn ₁ [kW]	n ₂ [rpm]	Fr1 [N]	Fr2 [N]
4270	45,77	7,17	15,3	3366	30000

IH123

Mn ₂ [Nm]	i	Pn ₁ [kW]	n ₂ [rpm]	Fr1 [N]	Fr2 [N]
4270	55,87	5,87	12,5	3486	30000
4270	67,32	4,87	10,4	3578	30000
4270	73,71	4,45	9,5	3617	30000
4270	83,34	3,94	8,4	3665	30000
4270	89,97	3,65	7,8	3692	30000
4275	100,29	3,27	7,0	3726	30000
4270	108,34	3,03	6,5	3749	30000
4270	118,62	2,77	5,9	3773	30000
4270	128,18	2,56	5,5	3792	30000
4275	144,79	2,27	4,8	3819	30000
4265	155,22	2,11	4,5	3834	30000
4270	172,80	1,90	4,0	3853	30000
4270	189,19	1,73	3,7	3869	30000
4270	207,43	1,58	3,4	3883	30000
4275	230,92	1,42	3,0	3898	30000

IH142

Mn ₂ [Nm]	i	Pn ₁ [kW]	n ₂ [rpm]	Fr1 [N]	Fr2 [N]
3320	5,27	47,35	132,7	4763	26746
3545	6,36	41,96	110,1	5430	28444
3610	7,04	38,56	99,4	5834	29660
3830	7,84	36,74	89,2	6059	30370
4700	9,45	37,41	74,1	5979	29582
5200	10,47	37,35	66,8	5982	29108
5275	13,07	30,36	53,5	6833	32777
5640	15,75	26,94	44,4	7251	34777
5710	17,45	24,61	40,1	7532	36535
5780	20,04	21,69	34,9	7885	39125
5780	24,15	18,00	29,0	8333	43263
5780	26,76	16,25	26,1	8547	45657
6835	32,24	15,95	21,7	8882	50210
6835	38,85	13,23	18,0	9160	55000
6835	43,05	11,94	16,3	9293	55000

IH143

Mn ₂ [Nm]	i	Pn ₁ [kW]	n ₂ [rpm]	Fr1 [N]	Fr2 [N]
6835	48,35	10,86	14,5	9428	55000
6835	53,53	9,81	13,1	9533	55000
6835	59,22	8,87	11,8	9628	55000

IH143

Mn ₂ [Nm]	i	Pn ₁ [kW]	n ₂ [rpm]	Fr1 [N]	Fr2 [N]
6835	62,99	8,34	11,1	9681	55000
6835	71,35	7,36	9,8	9780	55000
6835	79,07	6,64	8,8	9852	55000
6830	86,43	6,07	8,1	9909	55000
6835	96,21	5,46	7,3	9971	55000
6835	104,51	5,02	6,7	10014	55000
6830	115,92	4,53	6,0	10064	55000
6835	128,47	4,09	5,5	10109	55000
6835	139,55	3,76	5,0	10141	55000
6830	154,33	3,40	4,5	10178	55000
6835	185,96	2,82	3,8	10236	55000
6830	206,08	2,55	3,4	10264	55000

IHR041

Mn ₂ [Nm]	i	Pn ₁ [kW]	n ₂ [rpm]	Fr1 [N]	Fr2 [N]
21	1,44	1,09	487,0	925	812
21	2,00	0,78	350,0	1050	922
26	2,55	0,76	275,0	1064	981
26	2,71	0,71	257,9	1083	1000
34	3,11	0,82	225,4	1046	1000
38	3,59	0,79	195,1	1083	1000
38	4,20	0,67	166,7	1125	1000
38	5,00	0,57	140,0	1164	1000
43	5,50	0,58	127,3	1162	1000
43	6,09	0,53	114,9	1182	1000
43	7,67	0,42	91,3	1221	1000
47	8,75	0,40	80,0	1226	1000

IHR051

Mn ₂ [Nm]	i	Pn ₁ [kW]	n ₂ [rpm]	Fr1 [N]	Fr2 [N]
34	1,27	1,99	550,0	715	2032
51	1,42	2,68	493,2	514	1990
51	2,13	1,79	329,4	806	2336
60	2,57	1,74	272,2	833	2453
68	3,17	1,60	221,1	878	2500
77	3,69	1,55	189,8	925	2500
77	4,00	1,43	175,0	961	2500
81	4,77	1,26	146,8	1011	2500
85	5,25	1,21	133,3	1028	2500

IHR051

Mn_2 [Nm]	i	Pn_1 [kW]	n2 [rpm]	Fr1 [N]	Fr2 [N]
85	5,82	1,09	120,3	1063	2500
85	7,33	0,86	95,5	1132	2500
86	8,38	0,76	83,6	1164	2500

IHR061

Mn_2 [Nm]	i	Pn_1 [kW]	n2 [rpm]	Fr1 [N]	Fr2 [N]
68	1,34	3,77	520,9	1805	2948
103	2,13	3,61	329,4	2013	3378
102	2,57	2,95	272,2	2119	3593
111	3,17	2,61	221,1	2280	3700
128	3,69	2,58	189,8	2336	3700
128	4,00	2,38	175,0	2386	3700
137	4,77	2,14	146,8	2448	3700
145	5,25	2,06	133,3	2466	3700
145	5,82	1,86	120,3	2516	3700
145	7,33	1,47	95,5	2611	3700
145	8,38	1,29	83,6	2656	3700

IHR081

Mn_2 [Nm]	i	Pn_1 [kW]	n2 [rpm]	Fr1 [N]	Fr2 [N]
171	1,30	9,81	539,6	565	3183
188	1,43	9,80	490,0	588	3258
196	1,93	7,56	362,5	1151	3637
238	2,54	6,97	275,4	1346	3939
264	3,25	6,05	215,4	1625	4000
264	3,72	5,28	188,1	1785	4000
272	4,00	5,06	175,0	1872	4000
272	4,67	4,34	150,0	2039	4000
282	5,54	3,79	126,4	2170	4000
290	6,08	3,55	115,1	2224	4000
298	7,50	2,96	93,3	2358	4000
298	8,44	2,63	82,9	2435	4000

IHR101

Mn_2 [Nm]	i	Pn_1 [kW]	n2 [rpm]	Fr1 [N]	Fr2 [N]
340	1,29	19,58	541,5	1453	3913
384	1,41	20,27	496,4	1454	3988

IHR101

Mn_2 [Nm]	i	Pn_1 [kW]	n2 [rpm]	Fr1 [N]	Fr2 [N]
384	2,03	14,07	344,4	2222	4596
468	2,48	14,04	282,1	2255	4821
510	3,27	11,60	213,9	2589	5000
510	3,70	10,26	189,2	2748	5000
520	4,22	9,17	165,8	2899	5000
530	4,88	8,09	143,6	3026	5000
530	5,27	7,49	132,9	3096	5000
545	6,23	6,51	112,3	3207	5000
555	7,55	5,48	92,8	3329	5000
555	8,40	4,92	83,3	3393	5000

IHR121

Mn_2 [Nm]	i	Pn_1 [kW]	n2 [rpm]	Fr1 [N]	Fr2 [N]
309	1,23	18,70	568,8	527	4897
417	1,42	21,90	494,1	713	5103
595	1,81	24,52	387,5	1408	5601
640	2,00	23,82	350,0	1529	5779
680	2,48	20,41	282,3	1894	6000
680	2,95	17,13	236,9	2222	6000
700	3,14	16,58	222,7	2285	6000
725	3,58	15,08	195,6	2469	6000
725	4,12	13,11	170,0	2660	6000
740	4,80	11,48	145,8	2815	6000
750	5,21	10,71	134,2	2892	6000
765	6,25	9,11	112,0	3045	6000
850	7,70	8,22	90,9	3132	6000

IHA32

Mn ₂ [Nm]	i	Pn ₁ [kW]	n ₂ [rpm]	Fr1 [N]	Fr2 [N]
58	5,38	0,58	93,0	330	1545
58	6,52	0,48	76,7	409	1647
54	8,11	0,36	61,6	373	1772
65	10,94	0,32	45,7	441	1958
58	13,25	0,23	37,7	363	2000
58	16,49	0,19	30,3	398	2000
65	20,26	0,17	24,7	453	2000
61	24,55	0,13	20,4	386	2000
68	30,55	0,12	16,4	374	2000
77	35,44	0,12	14,1	480	2000
77	44,10	0,09	11,3	398	2000
68	48,75	0,07	10,3	398	2000
81	60,67	0,07	8,2	472	2000

IHA33

Mn ₂ [Nm]	i	Pn ₁ [kW]	n ₂ [rpm]	Fr1 [N]	Fr2 [N]
84	51,32	0,09	9,7	472	2000
85	59,65	0,08	8,4	472	2000
87	72,27	0,07	6,9	472	2000
84	89,94	0,05	5,6	472	2000
85	110,51	0,04	4,5	472	2000
88	133,88	0,04	3,7	472	2000
82	166,61	0,03	3,0	472	2000
85	193,30	0,02	2,6	472	2000
79	240,55	0,02	2,1	472	2000
92	279,07	0,02	1,8	472	2000
76	347,29	0,01	1,4	472	2000

IHA41

Mn ₂ [Nm]	i	Pn ₁ [kW]	n ₂ [rpm]	Fr1 [N]	Fr2 [N]
21	1,45	0,77	345,2	330	721
21	2,94	0,38	169,8	330	914
26	4,75	0,29	105,3	330	1071
26	5,45	0,25	91,7	330	1100
21	7,88	0,14	63,5	330	1100
17	10,83	0,08	46,1	330	1100

IHA42

Mn_2 [Nm]	i	Pn_1 [kW]	n2 [rpm]	Fr1 [N]	Fr2 [N]
101	5,38	1,00	93,0	330	3253
101	6,52	0,83	76,7	409	3468
94	8,11	0,62	61,6	369	3730
108	10,94	0,53	45,7	424	4121
101	13,25	0,41	37,7	381	4300
101	16,49	0,33	30,3	398	4300
108	20,26	0,29	24,7	432	4300
112	24,55	0,24	20,4	422	4300
120	30,55	0,21	16,4	359	4300
128	35,44	0,19	14,1	457	4300
120	44,10	0,15	11,3	371	4300
111	48,75	0,12	10,3	416	4300
120	60,67	0,11	8,2	428	4300

IHA43

Mn_2 [Nm]	i	Pn_1 [kW]	n2 [rpm]	Fr1 [N]	Fr2 [N]
129	51,32	0,14	9,7	427	4300
127	59,65	0,12	8,4	426	4300
127	72,27	0,10	6,9	409	4300
128	89,94	0,08	5,6	398	4300
127	110,51	0,06	4,5	403	4300
125	133,88	0,05	3,7	409	4300
128	166,61	0,04	3,0	398	4300
127	193,30	0,04	2,6	427	4300
132	240,55	0,03	2,1	398	4300
122	279,07	0,02	1,8	427	4300
133	347,29	0,02	1,4	398	4300

IHA51

Mn_2 [Nm]	i	Pn_1 [kW]	n2 [rpm]	Fr1 [N]	Fr2 [N]
34	1,45	1,24	345,2	330	1987
34	2,94	0,61	169,8	330	2517
43	4,75	0,48	105,3	330	2952
43	5,45	0,42	91,7	330	3000
34	7,88	0,23	63,5	330	3000
21	10,83	0,10	46,1	330	3000

IHA52

Mn ₂ [Nm]	i	Pn ₁ [kW]	n ₂ [rpm]	Fr1 [N]	Fr2 [N]
173	5,14	1,80	97,2	550	4006
173	6,22	1,49	80,4	682	4269
173	7,73	1,20	64,7	664	4589
216	9,64	1,20	51,9	827	4940
202	11,67	0,93	42,9	636	5264
202	14,50	0,74	34,5	664	5659
216	16,91	0,68	29,6	758	5957
208	20,46	0,54	24,4	659	6000
202	25,43	0,42	19,7	641	6000
216	29,89	0,39	16,7	752	6000
256	36,17	0,38	13,8	682	6000
238	44,95	0,28	11,1	620	6000
256	49,78	0,27	10,0	798	6000
246	61,87	0,21	8,1	642	6000

IHA53

Mn ₂ [Nm]	i	Pn ₁ [kW]	n ₂ [rpm]	Fr1 [N]	Fr2 [N]
256	49,80	0,28	10,0	330	6000
256	60,25	0,23	8,3	409	6000
254	74,88	0,19	6,7	398	6000
254	88,02	0,16	5,7	421	6000
256	111,61	0,13	4,5	390	6000
258	138,71	0,10	3,6	398	6000
258	163,05	0,09	3,1	421	6000
252	200,27	0,07	2,5	403	6000
256	235,41	0,06	2,1	421	6000
248	284,81	0,05	1,8	409	6000
252	353,98	0,04	1,4	398	6000

IHA61

Mn ₂ [Nm]	i	Pn ₁ [kW]	n ₂ [rpm]	Fr1 [N]	Fr2 [N]
77	1,33	3,06	375,0	550	2893
77	2,50	1,63	200,0	550	3568
94	4,38	1,13	114,0	550	4303
77	7,75	0,53	64,5	550	4500
60	10,67	0,30	46,9	550	4500

IHA62

Mn ₂ [Nm]	i	Pn ₁ [kW]	n ₂ [rpm]	Fr1 [N]	Fr2 [N]
274	5,14	2,85	97,2	550	5913
274	6,22	2,35	80,4	682	6300
274	7,73	1,89	64,7	664	6774
332	9,64	1,84	51,9	801	7291
318	11,67	1,46	42,9	652	7769
302	14,50	1,11	34,5	634	8000
360	16,91	1,14	29,6	842	8000
332	20,46	0,87	24,4	627	8000
310	25,43	0,65	19,7	621	8000
324	29,89	0,58	16,7	734	8000
400	36,17	0,59	13,8	712	8000
376	44,95	0,45	11,1	621	8000
316	49,78	0,34	10,0	626	8000
376	61,87	0,32	8,1	789	8000

IHA63

Mn ₂ [Nm]	i	Pn ₁ [kW]	n ₂ [rpm]	Fr1 [N]	Fr2 [N]
408	49,80	0,45	10,0	330	8000
408	60,25	0,37	8,3	409	8000
410	74,88	0,30	6,7	398	8000
408	88,02	0,25	5,7	421	8000
408	111,61	0,20	4,5	390	8000
410	138,71	0,16	3,6	398	8000
410	163,05	0,14	3,1	421	8000
406	200,27	0,11	2,5	403	8000
412	235,41	0,10	2,1	421	8000
404	284,81	0,08	1,8	409	8000
406	353,98	0,06	1,4	398	8000

IH032

Mn ₂ [Nm]	i	Pn ₁ [kW]	n ₂ [rpm]	Fr1 [N]	Fr2 [N]
69	4,70	0,79	106,5	647	4553
76	6,23	0,65	80,3	773	4995
90	7,76	0,62	64,4	801	5241
94	8,87	0,57	56,4	855	5486
101	10,14	0,53	49,3	888	5500
105	11,76	0,48	42,5	943	5500
123	13,72	0,48	36,4	940	5500
123	14,66	0,45	34,1	970	5500

IH032

Mn ₂ [Nm]	i	Pn ₁ [kW]	n ₂ [rpm]	Fr1 [N]	Fr2 [N]
137	16,77	0,44	29,8	980	5500
145	18,20	0,43	27,5	993	5500
145	19,90	0,39	25,1	1028	5500
145	22,68	0,34	22,1	1074	5500
145	23,83	0,33	21,0	1090	5500
145	26,39	0,29	18,9	1120	5500
146	29,70	0,26	16,8	1152	5500
171	32,89	0,28	15,2	1176	5500
171	37,92	0,24	13,2	1207	5500
171	41,40	0,22	12,1	1223	5500
171	47,25	0,19	10,6	1245	5500

IH033

Mn ₂ [Nm]	i	Pn ₁ [kW]	n ₂ [rpm]	Fr1 [N]	Fr2 [N]
170	53,59	0,17	9,3	1264	5500
172	66,78	0,14	7,5	1292	5500
172	74,84	0,13	6,7	1304	5500
169	99,27	0,09	5,0	1328	5500
172	108,05	0,09	4,6	1335	5500
169	123,71	0,07	4,0	1343	5500
173	143,33	0,07	3,5	1352	5500
166	178,61	0,05	2,8	1362	5500
173	197,17	0,05	2,5	1366	5500
175	245,70	0,04	2,0	1373	5500

IH042

Mn ₂ [Nm]	i	Pn ₁ [kW]	n ₂ [rpm]	Fr1 [N]	Fr2 [N]
116	5,46	1,14	91,5	359	5916
116	7,19	0,86	69,6	616	6600
152	8,91	0,91	56,1	568	6600
173	10,31	0,90	48,5	579	6600
181	11,80	0,82	42,4	655	6600
181	13,57	0,71	36,8	756	6600
181	15,96	0,61	31,3	857	6600
181	19,00	0,51	26,3	948	6600
181	21,00	0,46	23,8	994	6600
188	23,15	0,43	21,6	1018	6600
188	26,04	0,39	19,2	1064	6600
202	27,50	0,39	18,2	1057	6600

IH042

Mn_2 [Nm]	i	Pn_1 [kW]	n_2 [rpm]	Fr_1 [N]	Fr_2 [N]
238	30,45	0,42	16,4	1093	6600
238	34,10	0,37	14,7	1129	6600
238	37,76	0,34	13,2	1158	6600
238	43,75	0,29	11,4	1195	6600
238	47,53	0,27	10,5	1213	6600
238	54,25	0,23	9,2	1240	6600

IH043

Mn_2 [Nm]	i	Pn_1 [kW]	n_2 [rpm]	Fr_1 [N]	Fr_2 [N]
256	61,83	0,23	8,1	1251	6600
256	76,67	0,18	6,5	1286	6600
256	87,05	0,16	5,7	1303	6600
256	114,55	0,12	4,4	1333	6600
256	125,69	0,11	4,0	1341	6600
256	142,04	0,10	3,5	1351	6600
256	165,38	0,08	3,0	1362	6600
256	205,07	0,07	2,4	1375	6600
256	227,50	0,06	2,2	1380	6600
256	282,10	0,05	1,8	1390	6600

IH052

Mn_2 [Nm]	i	Pn_1 [kW]	n_2 [rpm]	Fr_1 [N]	Fr_2 [N]
188	5,73	1,76	87,3	174	7357
208	6,89	1,61	72,5	264	7730
244	8,53	1,53	58,6	323	8000
266	9,56	1,49	52,3	355	8000
280	11,51	1,30	43,4	485	8000
310	14,24	1,16	35,1	584	8000
324	16,59	1,04	30,1	667	8000
332	18,00	0,99	27,8	709	8000
332	19,97	0,89	25,0	777	8000
338	21,67	0,83	23,1	813	8000
338	24,71	0,73	20,2	885	8000
354	26,18	0,72	19,1	894	8000
354	28,44	0,67	17,6	934	8000
418	31,52	0,71	15,9	979	8000
418	33,00	0,68	15,2	998	8000
418	38,98	0,57	12,8	1059	8000
418	45,36	0,49	11,0	1107	8000

IH052

Mn_2 [Nm]	i	Pn_1 [kW]	n_2 [rpm]	Fr_1 [N]	Fr_2 [N]
418	49,13	0,45	10,2	1129	8000
418	56,11	0,40	8,9	1163	8000

IH053

Mn_2 [Nm]	i	Pn_1 [kW]	n_2 [rpm]	Fr_1 [N]	Fr_2 [N]
428	58,81	0,40	8,5	1169	8000
426	72,75	0,32	6,9	1213	8000
426	90,51	0,26	5,5	1249	8000
428	108,95	0,21	4,6	1275	8000
428	134,76	0,17	3,7	1298	8000
430	157,29	0,15	3,2	1313	8000
426	194,56	0,12	2,6	1329	8000
426	216,38	0,11	2,3	1336	8000
424	267,65	0,09	1,9	1348	8000

IH062

Mn_2 [Nm]	i	Pn_1 [kW]	n_2 [rpm]	Fr_1 [N]	Fr_2 [N]
360	5,38	3,58	93,0	703	11929
396	5,93	3,57	84,2	712	12000
396	7,39	2,86	67,7	1131	12000
432	8,50	2,72	58,8	1219	12000
434	9,39	2,47	53,3	1372	12000
470	11,69	2,15	42,8	1563	12000
505	12,67	2,13	39,5	1571	12000
505	14,75	1,83	33,9	1751	12000
575	16,29	1,89	30,7	1713	12000
600	17,67	1,82	28,3	1762	12000
610	20,28	1,61	24,6	1878	12000
610	23,27	1,40	21,5	2002	12000
610	25,70	1,27	19,5	2081	12000
576	29,33	1,05	17,1	2215	12000
725	32,00	1,21	15,6	2231	12000
680	36,99	0,98	13,5	2345	12000
725	40,33	0,96	12,4	2357	12000
725	46,06	0,84	10,8	2417	12000

IH063

Mn ₂ [Nm]	i	Pn ₁ [kW]	n ₂ [rpm]	Fr1 [N]	Fr2 [N]
725	49,45	0,80	10,1	2447	12000
725	54,61	0,72	9,2	2484	12000
725	68,00	0,58	7,3	2554	12000
720	85,82	0,46	5,8	2614	12000
725	94,76	0,42	5,3	2635	12000
720	118,00	0,33	4,2	2676	12000
725	135,40	0,29	3,7	2697	12000
725	149,51	0,26	3,3	2711	12000
725	170,67	0,23	2,9	2727	12000
720	186,18	0,21	2,7	2737	12000
730	215,21	0,19	2,3	2751	12000
720	234,67	0,17	2,1	2758	12000
715	268,00	0,15	1,9	2769	12000

IH082

Mn ₂ [Nm]	i	Pn ₁ [kW]	n ₂ [rpm]	Fr1 [N]	Fr2 [N]
505	5,39	5,01	92,8	651	14821
505	5,95	4,54	84,1	872	15430
575	7,39	4,16	67,6	1045	16361
575	8,02	3,83	62,3	1198	16918
650	8,85	3,93	56,5	1163	17122
795	11,01	3,86	45,4	1195	17763
1010	13,50	4,00	37,0	1126	17920
1080	14,90	3,88	33,6	1181	18000
1080	16,62	3,48	30,1	1370	18000
1080	18,53	3,12	27,0	1539	18000
1155	19,38	3,19	25,8	1510	18000
1155	21,39	2,89	23,4	1651	18000
1155	22,80	2,71	21,9	1735	18000
1155	26,60	2,32	18,8	1917	18000
1155	27,88	2,21	17,9	1967	18000
1365	31,15	2,34	16,1	2076	18000
1365	34,38	2,12	14,6	2164	18000
1365	38,70	1,89	12,9	2258	18000
1365	42,75	1,71	11,7	2329	18000
1365	48,13	1,52	10,4	2405	18000

IH083

Mn ₂ [Nm]	i	Pn ₁ [kW]	n ₂ [rpm]	Fr1 [N]	Fr2 [N]
1365	56,53	1,32	8,8	2494	18000
1535	71,48	1,17	7,0	2551	18000
1535	78,87	1,06	6,3	2594	18000
1535	85,56	0,98	5,8	2626	18000
1535	98,09	0,85	5,1	2675	18000
1535	112,78	0,74	4,4	2718	18000
1540	124,44	0,68	4,0	2746	18000
1530	142,15	0,59	3,5	2778	18000
1530	154,76	0,54	3,2	2797	18000
1535	162,35	0,52	3,1	2807	18000
1540	179,13	0,47	2,8	2826	18000
1535	195,07	0,43	2,6	2841	18000
1535	222,78	0,38	2,2	2861	18000

IH102

Mn ₂ [Nm]	i	Pn ₁ [kW]	n ₂ [rpm]	Fr1 [N]	Fr2 [N]
1300	5,26	13,21	95,0	1554	16910
1445	6,36	12,16	78,7	1757	17669
1660	7,05	12,59	70,9	1671	17355
1805	8,27	11,66	60,4	1850	18004
2020	9,99	10,81	50,0	2012	18611
2170	11,09	10,47	45,1	2083	18853
2240	13,32	8,99	37,5	2365	20412
2310	16,09	7,68	31,1	2616	22000
2310	17,85	6,92	28,0	2761	22000
2310	19,85	6,22	25,2	2895	22000
2310	21,44	5,76	23,3	2984	22000
2385	23,97	5,32	20,9	3070	22000
2385	25,89	4,92	19,3	3146	22000
2385	28,73	4,44	17,4	3239	22000
2730	30,72	4,75	16,3	3319	22000
2730	34,20	4,27	14,6	3397	22000
2390	38,45	3,32	13,0	3551	22000
2820	41,30	3,65	12,1	3499	22000
2820	45,82	3,29	10,9	3557	22000
2820	51,52	2,93	9,7	3616	22000

IH103

Mn ₂ [Nm]	i	Pn ₁ [kW]	n ₂ [rpm]	Fr1 [N]	Fr2 [N]
2990	55,47	2,94	9,0	3623	22000
2985	69,69	2,34	7,2	3719	22000
2990	79,82	2,05	6,3	3766	22000
2990	84,16	1,94	5,9	3783	22000
2990	93,36	1,75	5,4	3813	22000
2985	100,07	1,63	5,0	3832	22000
2990	120,84	1,35	4,1	3877	22000
2985	134,06	1,22	3,7	3898	22000
2990	143,42	1,14	3,5	3910	22000
2985	160,82	1,01	3,1	3930	22000
2985	181,07	0,90	2,8	3948	22000
2990	194,21	0,84	2,6	3958	22000
2985	215,45	0,76	2,3	3971	22000
2610	242,59	0,59	2,1	3981	22000

IH122

Mn ₂ [Nm]	i	Pn ₁ [kW]	n ₂ [rpm]	Fr1 [N]	Fr2 [N]
2165	5,27	21,95	94,8	534	24467
2315	5,78	21,43	86,6	624	24843
2600	7,05	19,72	70,9	891	25926
2670	7,74	18,44	64,6	1092	26799
2745	8,48	17,32	59,0	1274	27668
2890	10,35	14,94	48,3	1653	29780
3180	12,66	13,43	39,5	1894	30000
3325	13,86	12,82	36,1	1990	30000
3470	16,92	10,96	29,6	2286	30000
3615	19,32	10,00	25,9	2439	30000
3615	20,57	9,40	24,3	2536	30000
3610	22,52	8,57	22,2	2665	30000
3615	24,47	7,90	20,4	2773	30000
3615	27,49	7,03	18,2	2912	30000
3610	29,86	6,46	16,7	3000	30000
4270	33,00	6,92	15,2	3098	30000
4270	36,13	6,32	13,8	3179	30000
4270	44,10	5,18	11,3	3332	30000

IH123

Mn ₂ [Nm]	i	Pn ₁ [kW]	n ₂ [rpm]	Fr1 [N]	Fr2 [N]
4270	45,77	5,09	10,9	3358	30000

IH123

Mn ₂ [Nm]	i	Pn ₁ [kW]	n ₂ [rpm]	Fr1 [N]	Fr2 [N]
4270	55,87	4,17	8,9	3479	30000
4270	67,32	3,46	7,4	3573	30000
4270	73,71	3,16	6,8	3612	30000
4270	83,34	2,80	6,0	3660	30000
4270	89,97	2,59	5,6	3688	30000
4275	100,29	2,33	5,0	3723	30000
4270	108,34	2,15	4,6	3746	30000
4270	118,62	1,97	4,2	3770	30000
4270	128,18	1,82	3,9	3789	30000
4275	144,79	1,61	3,5	3817	30000
4265	155,22	1,50	3,2	3831	30000
4270	172,80	1,35	2,9	3851	30000
4270	189,19	1,23	2,6	3867	30000
4270	207,43	1,12	2,4	3881	30000
4275	230,92	1,01	2,2	3896	30000

IH142

Mn ₂ [Nm]	i	Pn ₁ [kW]	n ₂ [rpm]	Fr1 [N]	Fr2 [N]
3320	5,27	33,66	94,8	4695	31484
3545	6,36	29,82	78,7	5370	33486
3610	7,04	27,41	71,0	5778	34880
3830	7,84	26,11	63,8	6007	35776
4700	9,45	26,59	52,9	5926	35303
5200	10,47	26,55	47,7	5928	35010
5275	13,07	21,58	38,2	6790	39149
5640	15,75	19,15	31,8	7212	41556
5710	17,45	17,49	28,6	7497	43556
5780	20,04	15,42	24,9	7854	46487
5780	24,15	12,80	20,7	8307	51117
5780	26,76	11,55	18,7	8523	53795
6835	32,24	11,33	15,5	8863	55000
6835	38,85	9,41	12,9	9145	55000
6835	43,05	8,49	11,6	9279	55000

IH143

Mn ₂ [Nm]	i	Pn ₁ [kW]	n ₂ [rpm]	Fr1 [N]	Fr2 [N]
6835	48,35	7,72	10,3	9415	55000
6835	53,53	6,97	9,3	9522	55000
6835	59,22	6,30	8,4	9618	55000

IH143

Mn ₂ [Nm]	i	Pn ₁ [kW]	n ₂ [rpm]	Fr1 [N]	Fr2 [N]
6835	62,99	5,93	7,9	9672	55000
6835	71,35	5,23	7,0	9771	55000
6835	79,07	4,72	6,3	9844	55000
6830	86,43	4,32	5,8	9902	55000
6835	96,21	3,88	5,2	9964	55000
6835	104,51	3,57	4,8	10009	55000
6830	115,92	3,22	4,3	10059	55000
6835	128,47	2,91	3,9	10104	55000
6835	139,55	2,67	3,6	10137	55000
6830	154,33	2,42	3,2	10174	55000
6835	185,96	2,01	2,7	10232	55000
6830	206,08	1,81	2,4	10260	55000

IHR041

Mn ₂ [Nm]	i	Pn ₁ [kW]	n ₂ [rpm]	Fr1 [N]	Fr2 [N]
21	1,44	0,77	347,8	919	923
21	2,00	0,56	250,0	1046	1000
26	2,55	0,54	196,4	1061	1000
26	2,71	0,51	184,2	1080	1000
34	3,11	0,58	161,0	1042	1000
38	3,59	0,56	139,3	1080	1000
38	4,20	0,48	119,0	1122	1000
38	5,00	0,40	100,0	1162	1000
43	5,50	0,41	90,9	1160	1000
43	6,09	0,37	82,1	1180	1000
43	7,67	0,30	65,2	1219	1000
47	8,75	0,28	57,1	1224	1000

IHR051

Mn ₂ [Nm]	i	Pn ₁ [kW]	n ₂ [rpm]	Fr1 [N]	Fr2 [N]
34	1,27	1,41	392,9	707	2304
51	1,42	1,90	352,3	504	2271
51	2,13	1,27	235,3	799	2500
60	2,57	1,23	194,4	827	2500
68	3,17	1,14	157,9	872	2500
77	3,69	1,10	135,6	919	2500
77	4,00	1,02	125,0	956	2500
81	4,77	0,90	104,8	1006	2500
85	5,25	0,86	95,2	1023	2500

IHR051

Mn ₂ [Nm]	i	Pn ₁ [kW]	n ₂ [rpm]	Fr1 [N]	Fr2 [N]
85	5,82	0,77	85,9	1060	2500
85	7,33	0,61	68,2	1128	2500
86	8,38	0,54	59,7	1161	2500

IHR061

Mn ₂ [Nm]	i	Pn ₁ [kW]	n ₂ [rpm]	Fr1 [N]	Fr2 [N]
68	1,34	2,68	372,1	1791	3343
103	2,13	2,56	235,3	2002	3700
102	2,57	2,10	194,4	2109	3700
111	3,17	1,85	157,9	2272	3700
128	3,69	1,84	135,6	2328	3700
128	4,00	1,69	125,0	2379	3700
137	4,77	1,52	104,8	2442	3700
145	5,25	1,46	95,2	2460	3700
145	5,82	1,32	85,9	2511	3700
145	7,33	1,05	68,2	2607	3700
145	8,38	0,92	59,7	2653	3700

IHR081

Mn ₂ [Nm]	i	Pn ₁ [kW]	n ₂ [rpm]	Fr1 [N]	Fr2 [N]
171	1,30	6,98	385,4	536	3614
188	1,43	6,96	350,0	560	3703
196	1,93	5,37	258,9	1128	4000
238	2,54	4,96	196,7	1326	4000
264	3,25	4,30	153,8	1609	4000
264	3,72	3,75	134,3	1770	4000
272	4,00	3,60	125,0	1858	4000
272	4,67	3,08	107,1	2027	4000
282	5,54	2,69	90,3	2160	4000
290	6,08	2,52	82,2	2214	4000
298	7,50	2,10	66,7	2350	4000
298	8,44	1,87	59,2	2427	4000

IHR101

Mn ₂ [Nm]	i	Pn ₁ [kW]	n ₂ [rpm]	Fr1 [N]	Fr2 [N]
340	1,29	13,92	386,8	1424	4447
384	1,41	14,41	354,6	1424	4537

IHR101

Mn_2 [Nm]	i	Pn_1 [kW]	n2 [rpm]	Fr1 [N]	Fr2 [N]
384	2,03	10,00	246,0	2202	5000
468	2,48	9,98	201,5	2235	5000
510	3,27	8,25	152,8	2573	5000
510	3,70	7,29	135,1	2734	5000
520	4,22	6,52	118,4	2886	5000
530	4,88	5,75	102,6	3015	5000
530	5,27	5,33	94,9	3086	5000
545	6,23	4,63	80,2	3198	5000
555	7,55	3,89	66,3	3321	5000
555	8,40	3,50	59,5	3387	5000

IHR121

Mn_2 [Nm]	i	Pn_1 [kW]	n2 [rpm]	Fr1 [N]	Fr2 [N]
435	1,23	18,70	406,2	487	5556
586	1,42	21,90	352,9	675	5794
595	1,81	17,43	276,8	1378	6000
640	2,00	16,93	250,0	1500	6000
680	2,48	14,51	201,6	1871	6000
680	2,95	12,18	169,2	2202	6000
700	3,14	11,79	159,1	2266	6000
725	3,58	10,72	139,7	2451	6000
725	4,12	9,32	121,4	2645	6000
740	4,80	8,16	104,2	2802	6000
750	5,21	7,61	95,9	2880	6000
765	6,25	6,48	80,0	3035	6000
850	7,70	5,84	64,9	3123	6000

All supplies effected by MOTOVARIO are governed exclusively by the general terms of sale that you can find on our website:

<http://www.motovario.com/eng/corporate/sales-conditions>

