



MOTORI CORRENTE CONTINUA

Ferrite, Terre rare, Trazione

DC SERVOMOTORS
Ferrite, Rare Earth, Traction



SIBONI
MOTORS AND SOLUTIONS



INDICE

INDEX

RAW DC MOTORS - Informazioni generali	6
<i>RAW DC MOTORS- General information</i>	
Serie 17 P	8
<i>17 P Series</i>	
Serie 30 P	11
<i>30 P Series</i>	
Serie 56 P	16
<i>56 P Series</i>	
Serie 65 P	21
<i>65 P Series</i>	
Dinamo Tachimetriche a Magneti Permanenti	26
<i>Permanent Magnet Tacho Generators</i>	
Designazione motore	28
<i>Purchasing Code</i>	
RED DC MOTORS - Informazioni generali	32
<i>RED DC MOTORS - General information</i>	
Serie N17	34
<i>N17 Series</i>	
Serie N45	37
<i>N45 Series</i>	
Serie N70	41
<i>N70 Series</i>	
Serie N100	45
<i>N100 Series</i>	
Designazione motore	49
<i>Purchasing Code</i>	
TRA DC MOTORS - Informazioni generali	52
<i>TRA DC MOTORS - General information</i>	
Serie 75 PXF	53
<i>75 PXF Series</i>	
Serie 75 PF	56
<i>75 PF Series</i>	
Serie 75 PS	59
<i>75 PS Series</i>	
Serie 75 PK	62
<i>75 PK Series</i>	
Serie 75 PX	65
<i>75 PX Series</i>	
Serie 75 PQ	68
<i>75 PQ Series</i>	
Designazione motore	70
<i>Purchasing Code</i>	





Ferrite





INFORMAZIONI GENERALI

GENERAL INFORMATION

Serie di motori in corrente continua studiati per la realizzazione di servomovimentazioni a velocità variabile. Le elevate competenze aziendali sulla tecnologia dei magneti permanenti in ferrite e l'accurata progettazione e realizzazione elettromeccanica, hanno permesso di ottenere un prodotto che unisce:

- Ottime potenze specifiche
- Inerzie contenute
- Eccellente rapporto qualità/prezzo

Inoltre la vasta gamma di avvolgimenti, configurazioni meccaniche e opzioni disponibili, rendono il prodotto flessibile ed adattabile ad ogni specifica esigenza

This dc permanent magnet motor series has been developed to meet the requirements of the industrial automation industry.

The vast experience that the company has acquired in the dc permanent magnet motor field has resulted in the evolution of a series of products which combine:

- *Optimum specific power*
- *Low inertia*
- *Excellent quality/price ratio*

Moreover the wide range of windings, mechanical configurations and options available, make these products flexible and readily adaptable to suit specific applications.

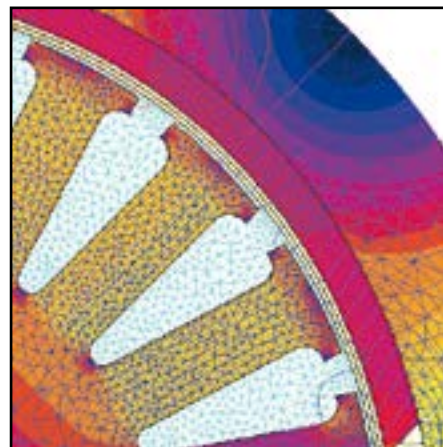
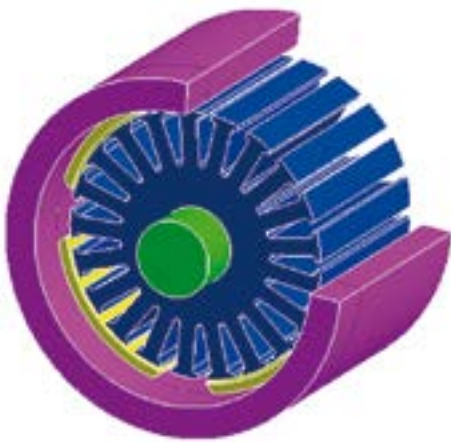

Modello 2D di servomotore cc che mostra l'andamento dell'induzione magnetica ed il reticolo di calcolo.

2D model of a dc servomotor showing the magnetic induction and the mesh used in the calculations

SPECIFICHE TECNICHE STANDARD

SPECIFICATIONS OF STANDARD MODELS

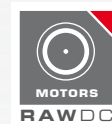

Tipo <i>Type</i>	Servomotori a corrente continua a magneti permanenti <i>Permanent magnet brushed motors</i>
Statore <i>Stator</i>	A magneti permanenti in Ferrite sinterizzata, incollati e protetti con ritenute meccaniche <i>Sintered ferrite permanent magnets mechanically fastened</i>
Isolamento <i>Insulation</i>	Motore e avvolgimento in classe F secondo DIN 0530 <i>Motor and winding in class F in accordance with DIN 0530</i>
Cuscinetti <i>Bearings</i>	Cuscinetti di alta qualità lubrificati a vita, bloccato anteriormente <i>High quality, life lubricated, front bearing locked</i>
Raffreddamento <i>Cooling</i>	Convezione naturale IC0041 <i>Natural convection IC0041</i>
Grado di Protezione <i>Level of Protection</i>	IP44 <i>IP44</i>

Opzioni disponibili

Available options

Trasduttore di Posizione <i>Position sensor</i>	Encoder incrementale risoluzione a richiesta, dinamo tachimetrica <i>Incremental encoder, tachometer generator</i>
Freno di sicurezza <i>Safety brake</i>	Coppia frenante > Coppia nominale motore <i>Holding torque > Rated torque of the electric motor</i>
Alimentazione <i>Power supply</i>	Cavo uscente su pressacavo, connettore tipo elettrovalvola IP55 <i>Cable, IP55 connector</i>
Grado di Protezione <i>Level of Protection</i>	IP 55 <i>IP55</i>



Serie 17 P

17 P Series

CARATTERISTICHE GENERALI - GENERAL CHARACTERISTICS

Tipo Type		17PC		17PL			
Tensione Nominale Rated Voltage	V	24		24			
Velocità Nominale Rated Speed	Rpm	3700	2900	3300	1500	2500	1100
Potenza Nominale Rated Power	W	12	9	19	8	10	5
Codice di Avvolgimento Winding Code		060	066	030	078	083	085

CARATTERISTICHE TECNICHE - TECHNICAL CHARACTERISTICS

Coppia Continuativa di Stallo Continuous Stall Current	Nm	0,045	0,045	0,06	0,07	0,06	0,05
Corrente Continuativa di Stallo Continuous Stall Torque	A	1,4	1	1,7	0,95	1,3	0,75
Coppia Nominale Rated Torque	Nm	0,03	0,03	0,055	0,05	0,04	0,04
Corrente Nominale Rated Current	A	1	0,75	1,3	0,55	0,8	0,35
Coppia di Picco allo Spunto Start Peak Torque	Nm	0,075	0,05	0,11	0,075	0,08	0,075
Corrente di Picco Start Peak Torque	A	2,3	1,2	3,1	1	1,8	0,75
Resistenza Totale Total Resistance	Ω	7,9	15,4	5,76	17,5	10,1	34,1
Induttanza Inductance	mH	4,16	6,49	3,09	11	5,25	18
Costante di Coppia Torque Constant	Nm/A	0,032	0,045	0,035	0,073	0,046	0,1
Costante di Tensione Voltage Constant	V/10 ³ Rpm	3,95	5,20	5,05	10	6,75	12,50
Costante di Tempo Elettrica Electrical Time Constant	ms	0,530	0,420	0,54	0,63	0,52	0,53

DATI MECCANICI - MECHANICAL DATA

Momento di Inerzia Moment of Inertia	Kg-m ²	3,2-10-6		5,2-10-6			
Massa Mass	Kg	0,3		0,4			
Massimo Carico Radiale Maximum Radial Load	N	80		90			
Massimo Carico Assiale Maximum Axial Load	N	40		50			

CARATTERISTICHE TERMICHE - THERMAL CHARACTERISTICS

Temperatura di Funzionamento Rated Temperature	°C	0 ÷ 40					
Classe di Isolamento Type of Insulation		F					
Grado di Protezione Level of Protection		IP44					
Montaggio Mounting		In Aria / Free Still Air					

Dati rilevati a temperatura ambiente di 25° C e con temperatura massima del collettore di 115°C.
The data was obtained at a room temperature of 25 °C with 115°C on the commutator.

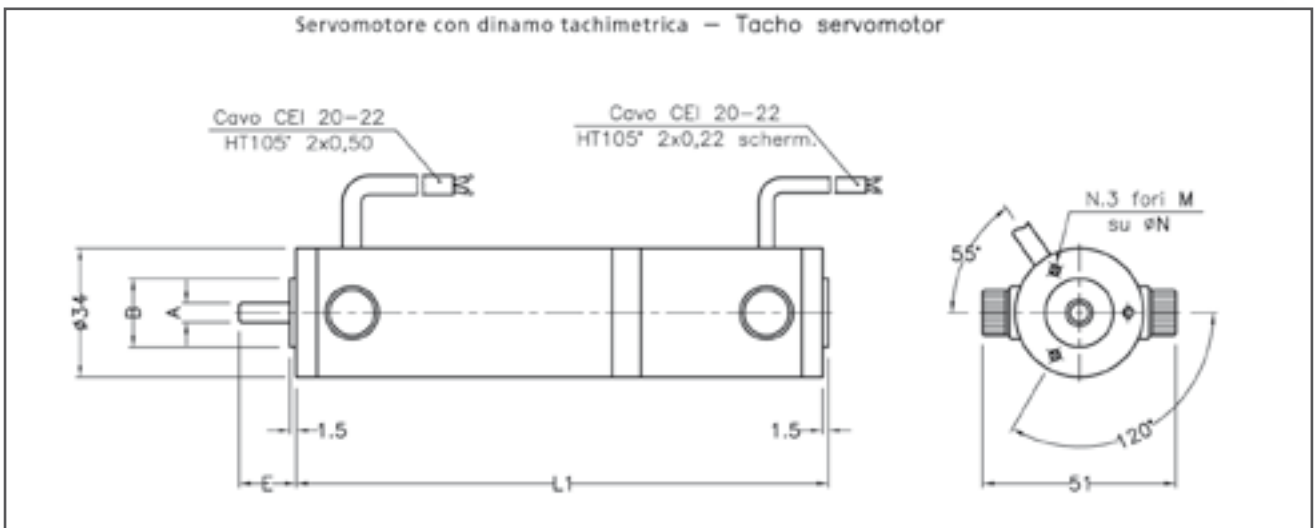
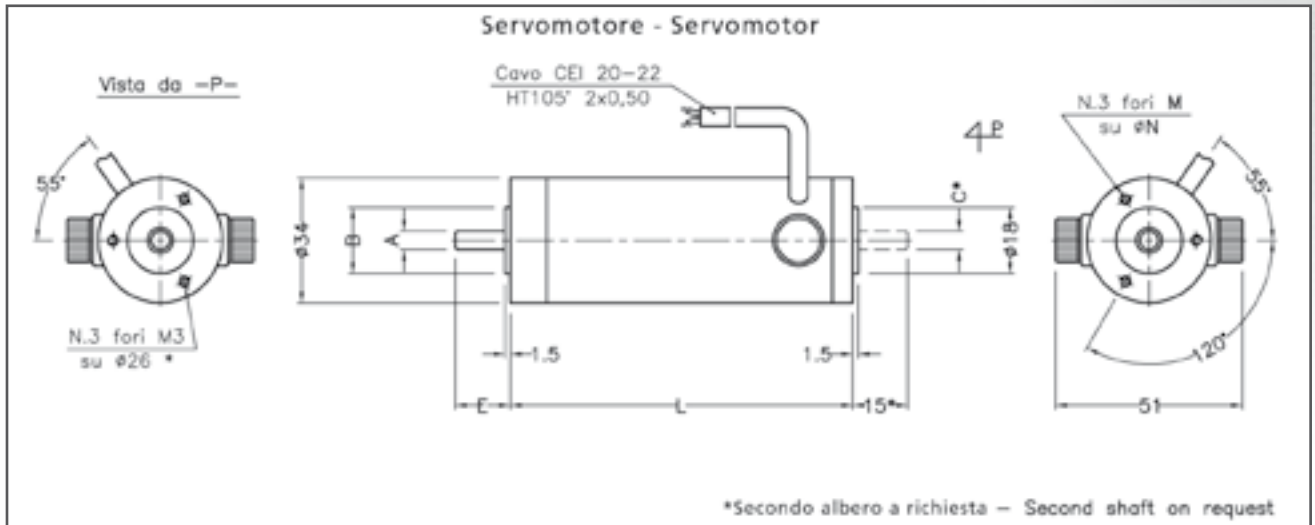

Tolleranze sulle dimensioni angolari : $\pm 5^\circ$
 The tolerance on angular dimensions: $\pm 5^\circ$

Opzionali

Optionals

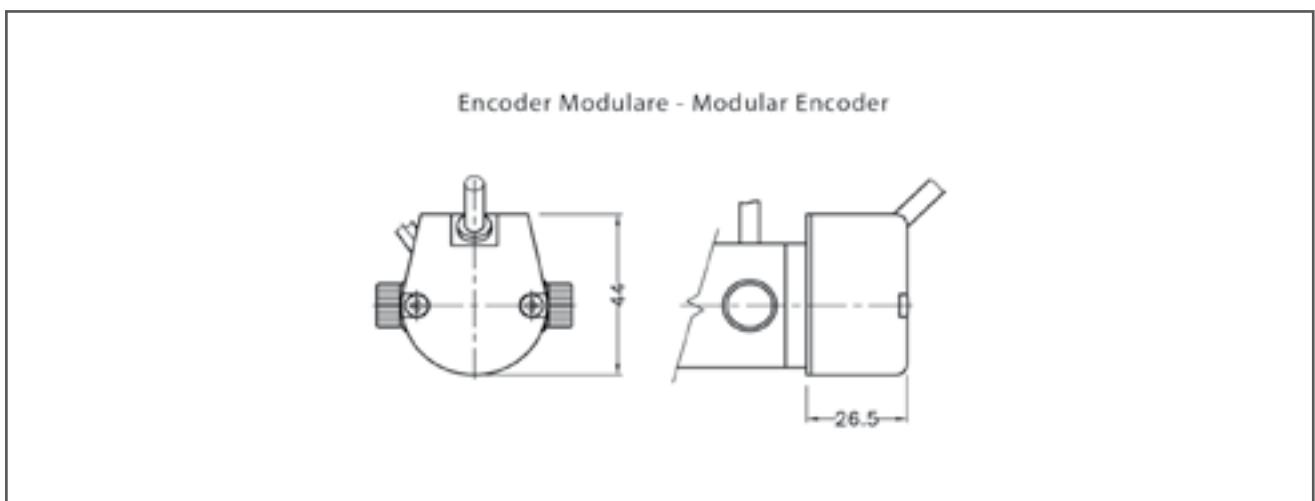



Serie 17 P

17 P Series

DIMENSIONI - DIMENSIONS

Taglia Size	Tipo di Flangia Flange type	A ^{h6}	B ^{h7}	C ^{h6}	E ^{0,2}	L ^{0,5}	L1 ^{0,5}	M	N	Linguetta Key
17PC	Standard	5	18	5/6	15	74	121,5	M3	26	-
17PL	Standard	5	18	5/6	15	95	140,5	M3	26	-

Caratteristiche Coppia-Velocità

Torque-Speed characteristics

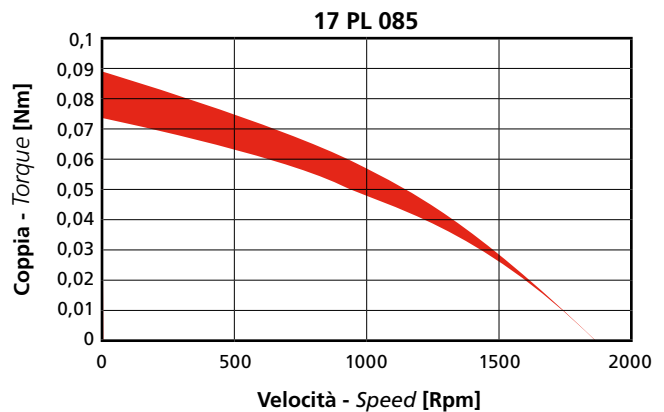
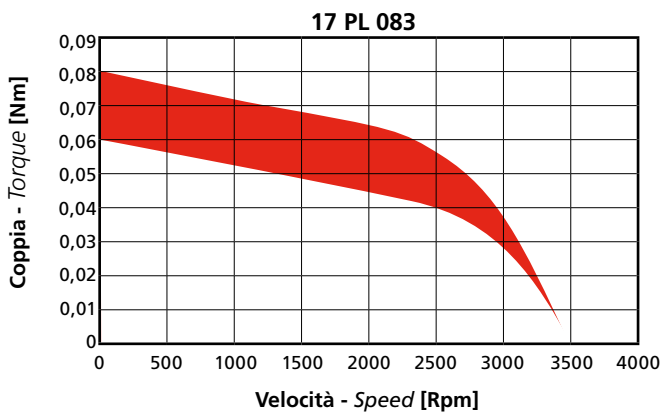
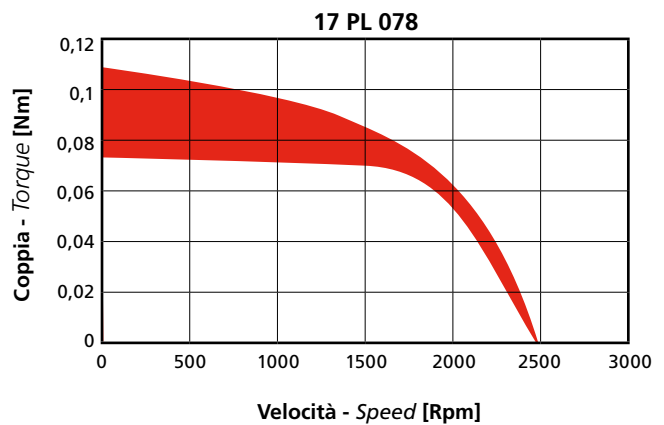
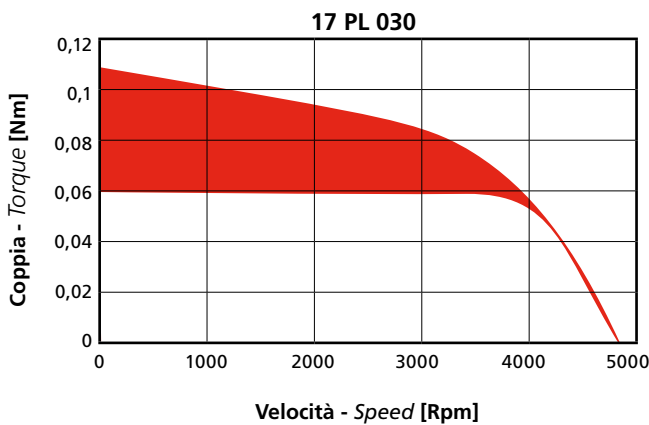
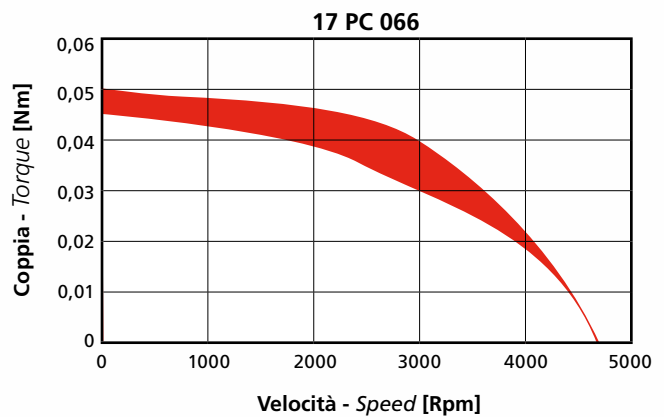
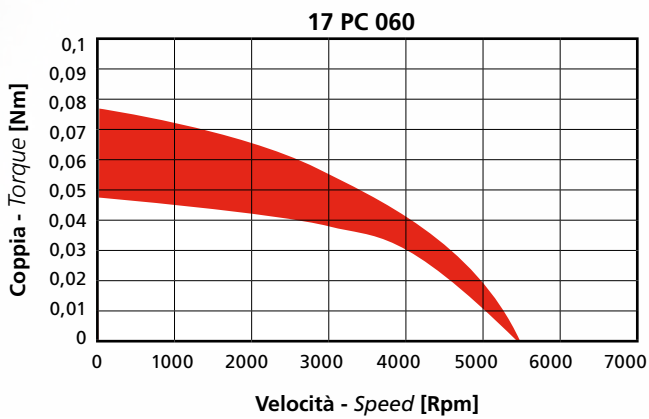

■ S1

■ S2, 50% 30 min.

Serie 30 P

30 P Series

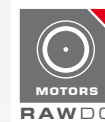

CARATTERISTICHE GENERALI - GENERAL CHARACTERISTICS

Tipo Type		30PS	30PC		30PM				30PL		
Tensione Nominale Rated Voltage	V	24	24		24		48		24		42
Velocità Nominale Rated Speed	Rpm	2750	2700	1500	3000	1950	2900	1700	2600	1700	2500
Potenza Nominale Rated Power	W	27	34	22	66	45	67	45	87	57	89
Codice di Avvolgimento Winding Code		039	008	009	010	068	038	069	011	086	082

CARATTERISTICHE TECNICHE - TECHNICAL CHARACTERISTICS

Coppia Continuativa di Stallo Continuous Stall Current	Nm	0,13	0,17	0,19	0,3	0,27	0,3	0,39	0,43	0,46	0,49
Corrente Continuativa di Stallo Continuous Stall Torque	A	2,5	3,1	2,1	5,2	3,4	2,5	2,1	6,3	4,7	4,1
Coppia Nominale Rated Torque	Nm	0,095	0,12	0,14	0,21	0,22	0,22	0,25	0,32	0,32	0,34
Corrente Nominale Rated Current	A	1,8	2,4	1,5	4,1	2,9	2	1,4	5	3,6	2,8
Coppia di Picco allo Spunto Start Peak Torque	Nm	0,27	0,44	0,32	1,05	0,65	1,2	0,8	1,45	1,15	1,85
Corrente di Picco Start Peak Torque	A	5,3	8	3,5	18,5	8,1	10	4,4	21	12	15,5
Resistenza Totale Total Resistance	Ω	3,38	2,23	5,07	0,97	2,2	3,25	8,1	0,85	1,51	2
Induttanza Inductance	mH	3,76	3,01	8,19	1,45	3,4	6,36	16,2	1	2,25	3,7
Costante di Coppia Torque Constant	Nm/A	0,052	0,054	0,090	0,057	0,080	0,12	0,186	0,068	0,097	0,119
Costante di Tensione Voltage Constant	V/10 ³ Rpm	6,65	6,95	11	6,65	9,75	13,5	21,5	7,7	12	13,5
Costante di Tempo Elettrica Electrical Time Constant	ms	1,1	1,3	1,6	1,5	1,5	1,9	2	1,2	1,5	1,8

DATI MECCANICI - MECHANICAL DATA

Momento di Inerzia Moment of Inertia	Kg·m ²	2·10 ⁻⁵	2,8·10 ⁻⁵		4,3·10 ⁻⁵				7,5·10 ⁻⁵		
Massa Mass	Kg	0,7	0,9		1,3				2		
Massimo Carico Radiale Maximum Radial Load	N	100	180		180				200		
Massimo Carico Assiale Maximum Axial Load	N	40	60		60				70		

CARATTERISTICHE TERMICHE - THERMAL CHARACTERISTICS

Temperatura di Funzionamento Rated Temperature	°C	0 ÷ 40 °C									
Classe di Isolamento Type of Insulation		F									
Grado di Protezione Level of Protection		IP44									
Montaggio Mounting		In Aria / Free Still Air									

Dati rilevati a temperatura ambiente di 25° C e con temperatura massima del collettore di 115°C.
The data was obtained at a room temperature of 25 °C with 115°C on the commutator.

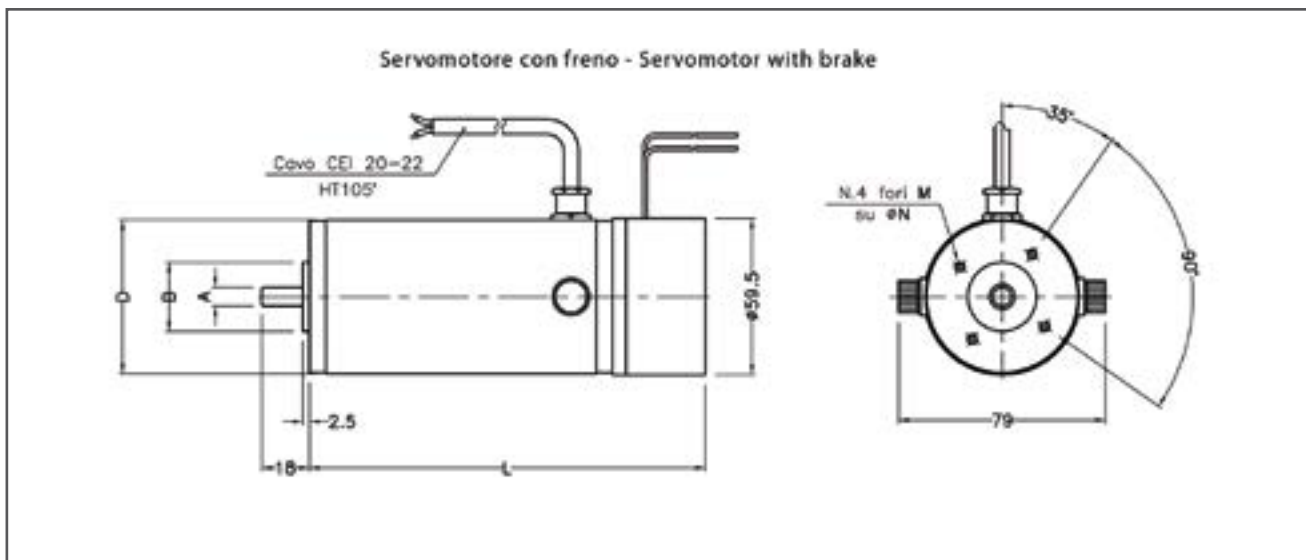
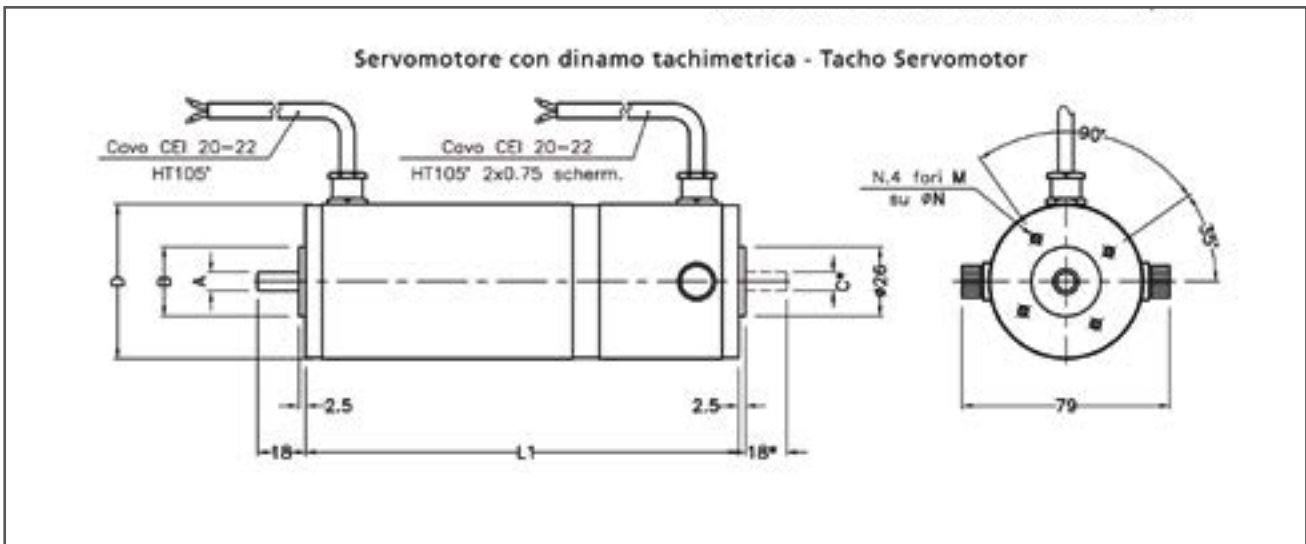
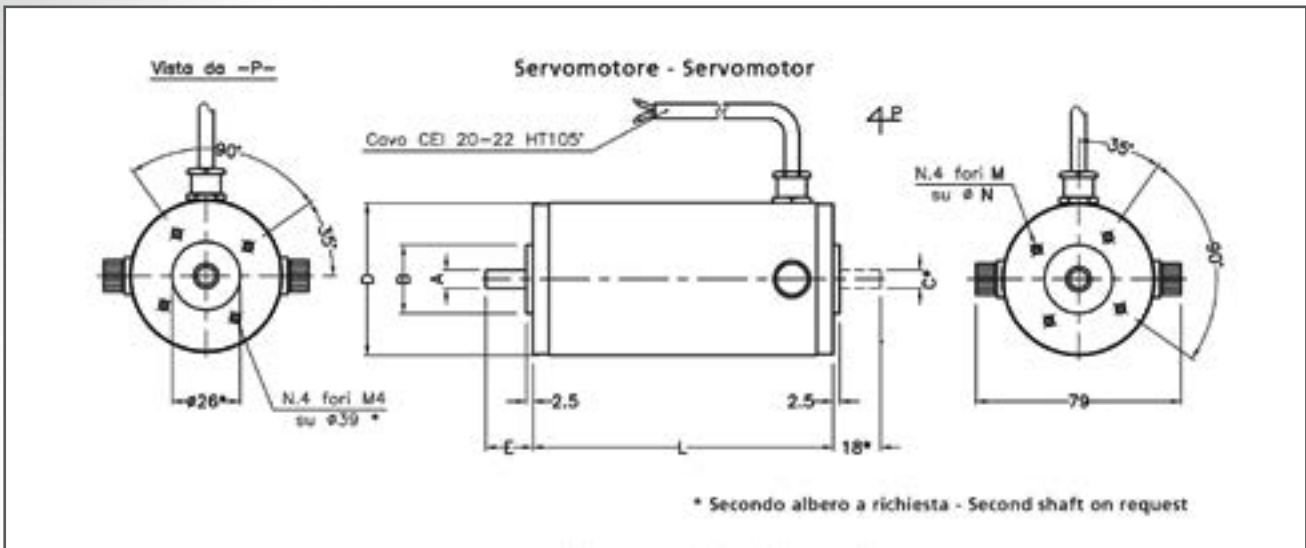

Tolleranze sulle dimensioni angolari : $\pm 5^\circ$
 The tolerance on angular dimensions : $\pm 5^\circ$

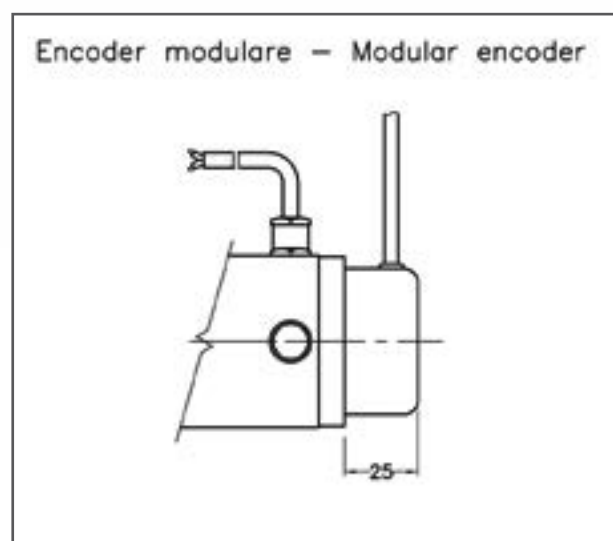
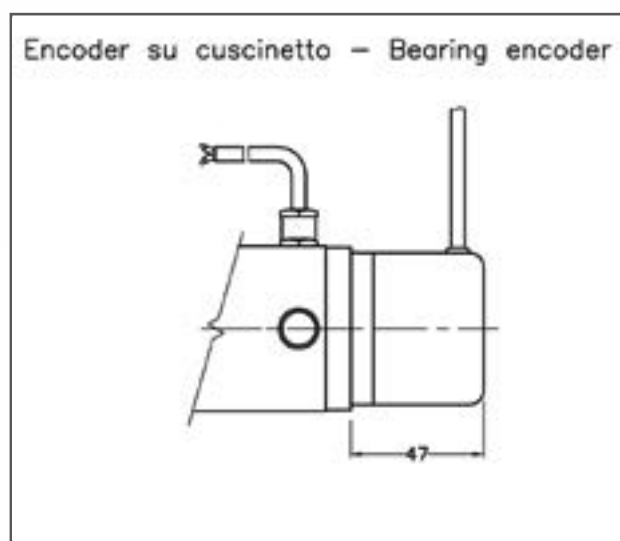
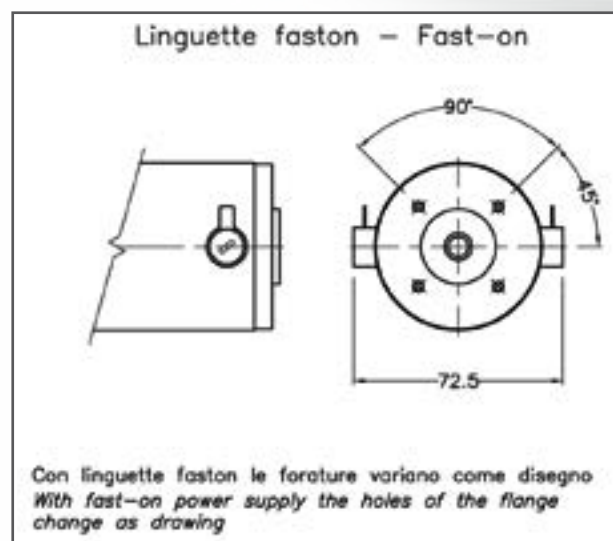
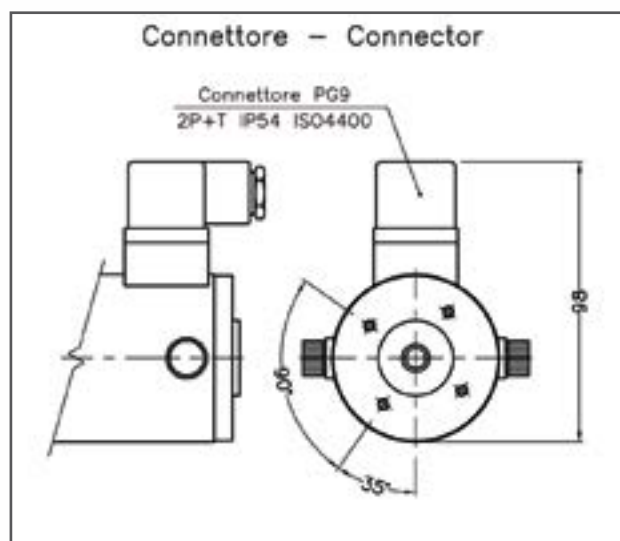

DIMENSIONI - DIMENSIONS

Taglia Size	Tipo di Flangia Flange type	A ^{h6}	B ^{h7}	C ^{h6}	D	E ^{±0.2}	L ^{±0.5}	L1 ^{±0.5}	M	N	Linguetta Key
30PS	Standard	6	26	6	58	18	72	-	M4	39	-
30PC	Standard	7	26	7	58	18	91	139	M4	39	-
	56B14	9	50	7	75	20	93	146	M5	65	3X3X15
30PM	Standard	7	26	7	58	18	117	165	M4	39	-
	56B14	9	50	7	75	20	119	172	M5	65	3x3x15
	63B14	11	60	7	60(*)	23	120	-	5,5	75	4x4x15
30 PL	Standard	9	26	7	58	25	168,5	222	M5	39	3x3x15
	56B14	9	50	7	75	20	170	223,5	M5	65	3x3x15
	63B14	11	60	7	60(*)	23	170	-	5,5	75	4x4x15

Le quote non indicate stanno a significare che la versione non è disponibile
 Per servomotori con freno di stazionamento, le quote L e L1 devono essere aumentate di 33 mm
 (*) La quota e riferita al lato di flangia quadrata
 Where the dimensions are not given the version is not available
 For servomotors with brake, the measurements L and L1 need to be increased by 33 mm.
 (*) This measurement refers to a square flange.



Caratteristiche Coppia-Velocità

Torque-Speed characteristics

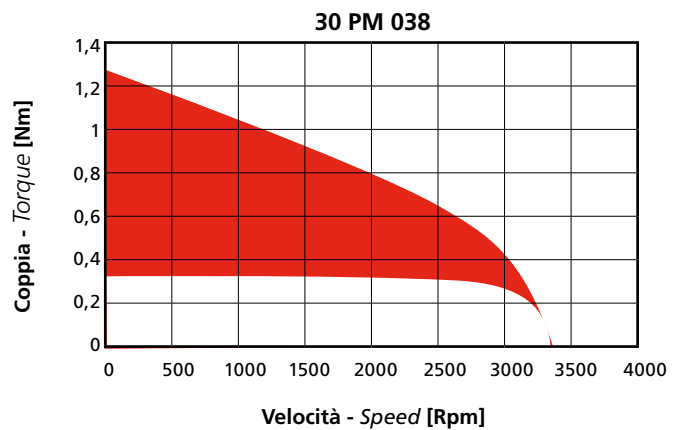
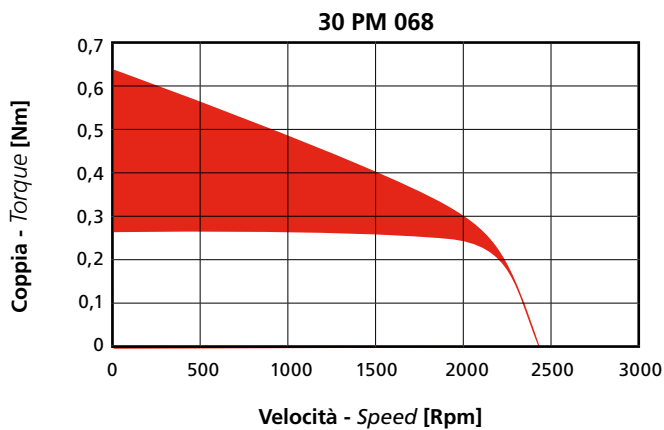
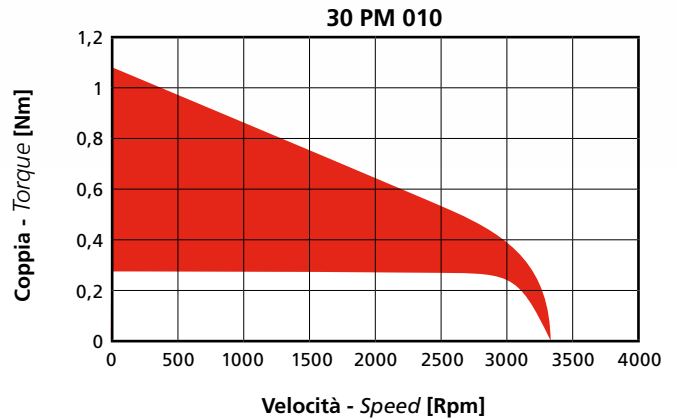
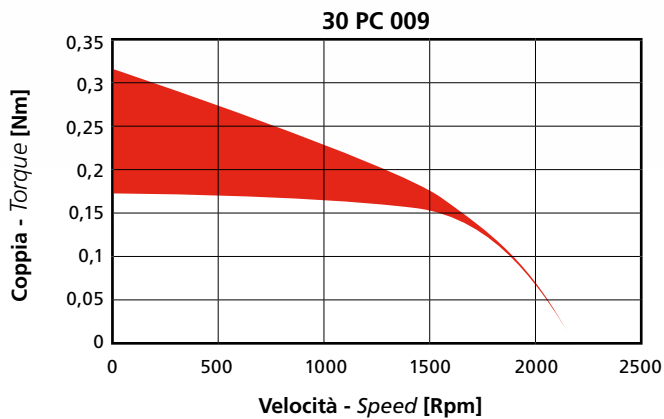
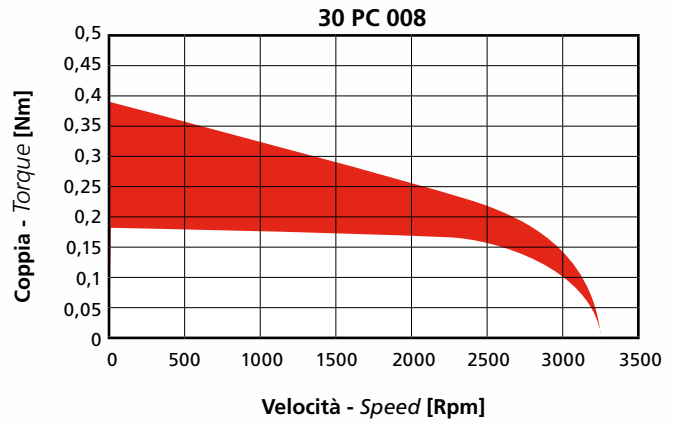
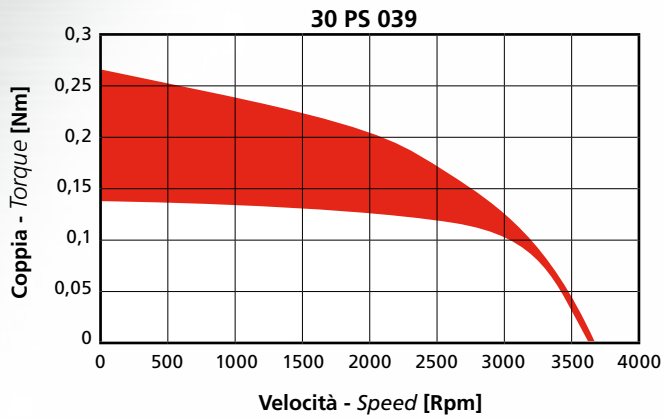

□ S1

■ S2, 30 min.

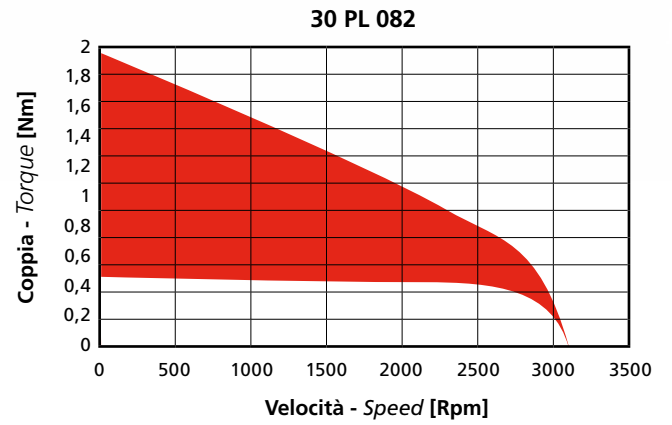
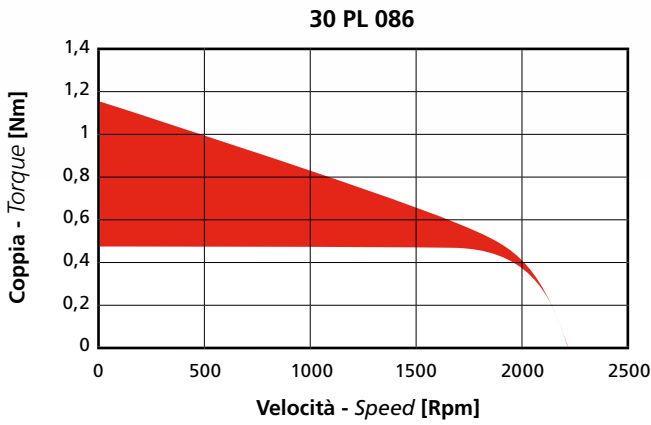
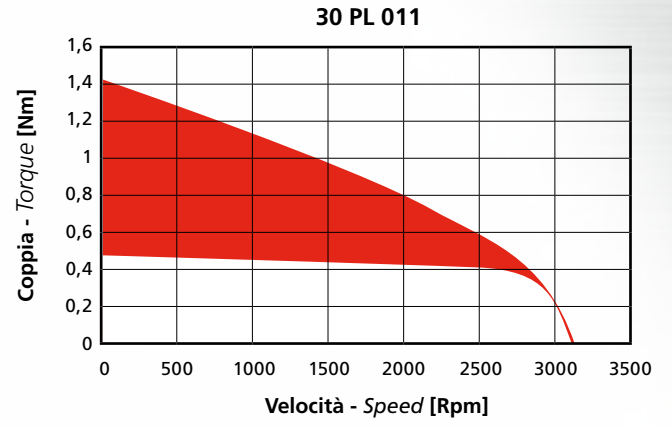
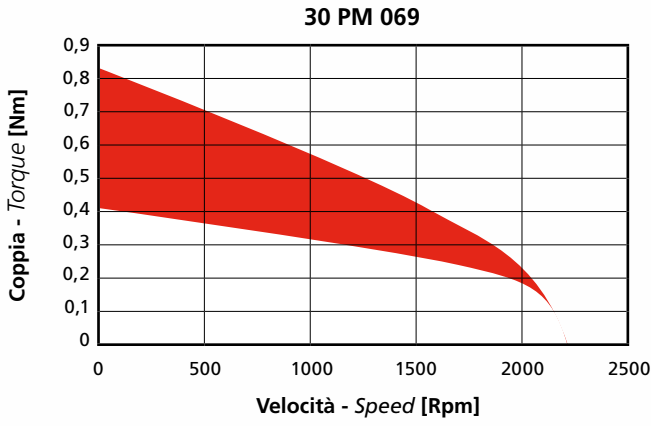

□ S1

■ S2, 30 min.



Serie 56 P

56 P Series

CARATTERISTICHE GENERALI - GENERAL CHARACTERISTICS

Tipo Type		56PC				56PM				56PL					
Tensione Nominale Rated Voltage	V	24		48		24		48		65		24		48	
Velocità Nominale Rated Speed	Rpm	1900	2600	2400	1850	1900	2400	2750	2000	2600	1800	1900	2800	1900	2700
Potenza Nominale Rated Power	W	86	114	126	89	109	123	173	136	177	123	149	176	129	184
Codice di Avvolgimento Winding Code		003	013	042	043	004	014	034	044	112	118	005	015	046	054

CARATTERISTICHE TECNICHE - TECHNICAL CHARACTERISTICS

Coppia Continuativa di Stallo Continuous Stall Current	Nm	0,46	0,49	0,55	0,5	0,7	0,65	0,7	0,7	0,75	0,75	0,85	0,8	0,9	0,8
Corrente Continuativa di Stallo Continuous Stall Torque	A	5,8	7,3	4	3,2	8,1	10	5,4	4,1	4	2,9	8,6	10	5,6	5,9
Coppia Nominale Rated Torque	Nm	0,43	0,42	0,5	0,46	0,55	0,49	0,60	0,65	0,65	0,65	0,75	0,6	0,65	0,65
Corrente Nominale Rated Current	A	5,4	6,3	3,7	2,8	6,6	8	4,6	3,7	3,5	2,7	7,8	9,7	4,3	5,4
Coppia di Picco allo Spunto Start Peak Torque	Nm	1,45	1,55	2,2	2	2,2	2,2	2,8	2,9	2,9	3	2,1	2,6	3,1	3,1
Corrente di Picco Start Peak Current	A	18	23	16	12	25	34	22	16,5	16	11,5	22	40	19	24
Resistenza Totale Total Resistance	Ω	0,98	0,76	1,93	2,98	0,7	0,52	1,64	1,9	1,94	3,86	0,82	0,37	1,85	1,45
Induttanza Inductance	mH	1,95	1,2	6,15	6,78	1,32	0,79	3,11	5,29	5,81	11	1,16	0,49	4,06	2,2
Costante di Coppia Torque Constant	Nm/A	0,079	0,067	0,14	0,165	0,086	0,065	0,13	0,176	0,182	0,255	0,096	0,065	0,158	0,132
Costante di Tensione Voltage Constant	V/10 ³ Rpm	9,6	7,85	16,5	19,5	10	7,7	14,5	20	20,5	28,5	11	7,25	20	15
Costante di Tempo Elettrica Electrical Time Constant	ms	2	1,6	3,2	2,3	1,9	1,5	1,9	2,8	3	2,8	1,4	1,3	2,2	1,5

DATI MECCANICI - MECHANICAL DATA

Momento di Inerzia Moment of Inertia	Kg.m ²	2,8·10 ⁻⁴				3,8·10 ⁻⁴				5·10 ⁻⁴			
Massa Mass	Kg	2,7				3,2				3,9			
Massimo Carico Radiale Maximum Radial Load	N	290				330				370			
Massimo Carico Assiale Maximum Axial Load	N	80				90				100			

CARATTERISTICHE TERMICHE - THERMAL CHARACTERISTICS

Temperatura di Funzionamento Rated Temperature	°C	0 ÷ 40 °C													
Classe di Isolamento Type of Insulation		F													
Grado di Protezione Level of Protection		IP44													
Montaggio Mounting		In Aria / Free Still Air													

Dati rilevati a temperatura ambiente di 25° C e con temperatura massima del collettore di 115°C.
The data was obtained at a room temperature of 25 °C with 115°C on the commutator.

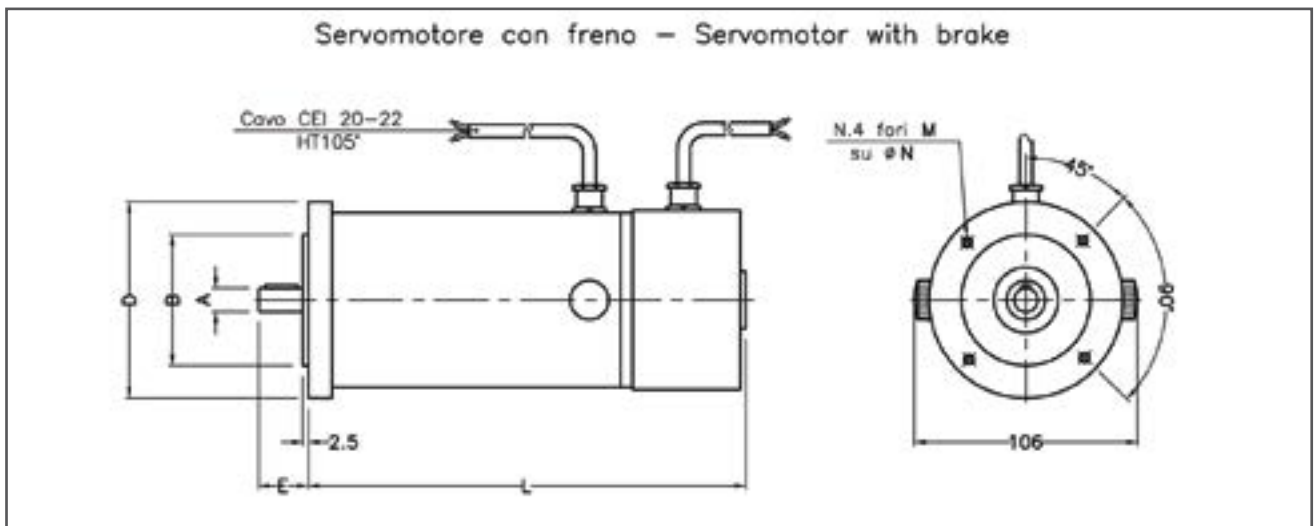
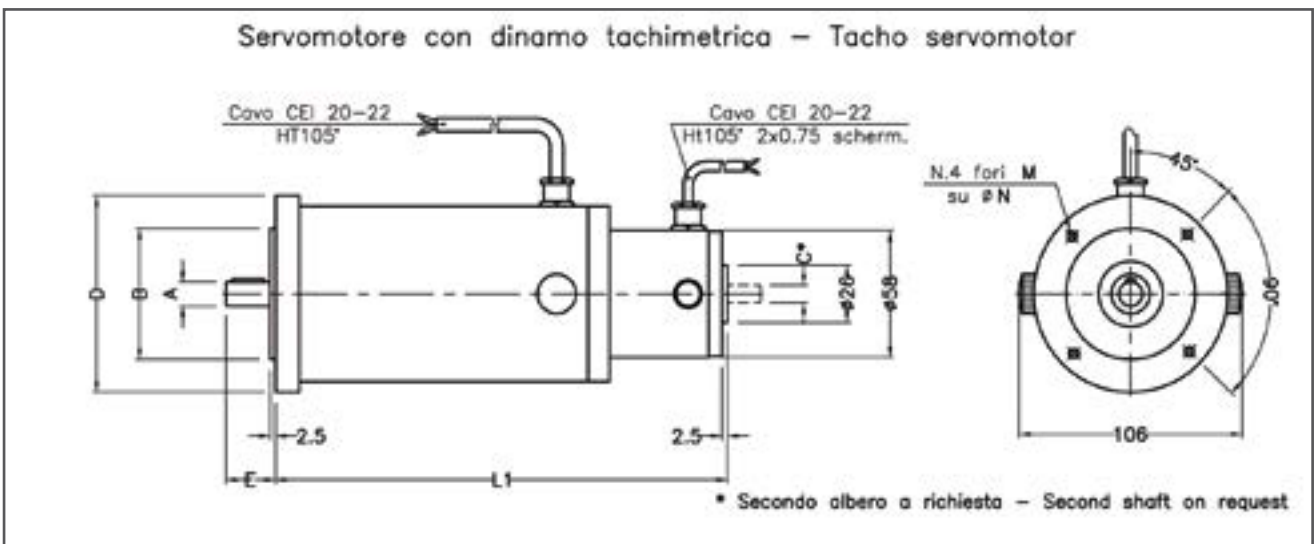
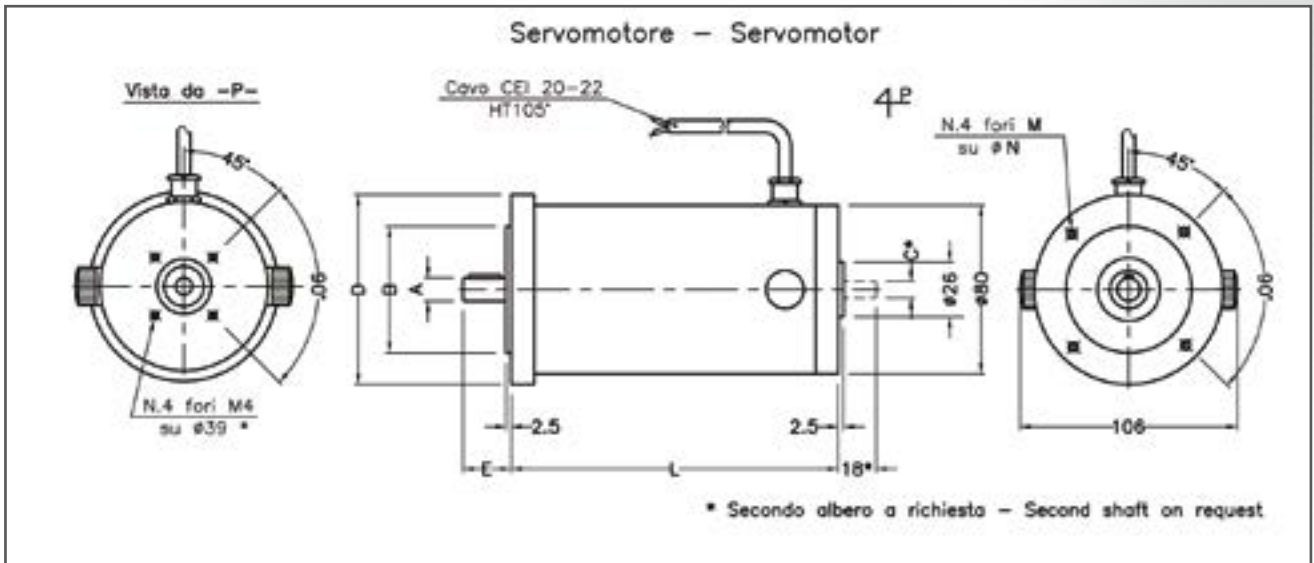

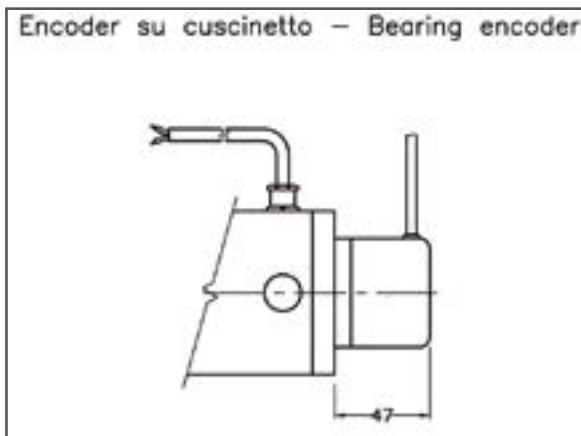
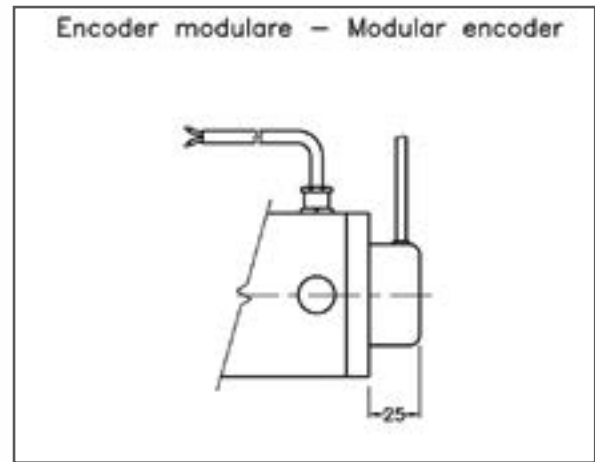
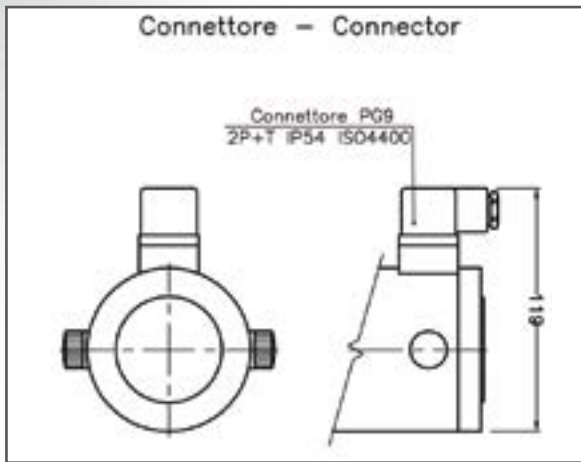

DIMENSIONI - DIMENSIONS

Taglia Size	Tipo di Flangia Flange type	A ^{h6}	B ^{h7}	C ^{h6}	D	E ^{±0,2}	L ^{±0,5}	L1 ^{±0,5}	M	N	Linguetta Key
56PC	56B14	9	50	8	80	20	140	192	M5	65	3X3X15
	63B14	11	60	8	90	23			M5	75	4X4X15
	63B5	11	95	8	140	23			8,5	115	4X4X15
56PM	56B14	9	50	8	80	20	157,5	210	M5	65	3X3X15
	63B14	11	60	8	90	23			M5	75	4X4X15
	63B5	11	95	8	140	23			8,5	115	4X4X15
56PL	56B14	9	50	8	80	20	185,5	238	M5	65	3X3X15
	63B14	11	60	8	90	23			M5	75	4X4X15
	63B5	11	95	8	140	23			8,5	115	4X4X15

Per servomotori con freno di stazionamento, le quote L e L1 devono essere aumentate di 46 mm
 For servomotors with brake, the measurements L and L1 need to be increased by 46 mm.

Caratteristiche Coppia-Velocità

Torque-Speed characteristics



56 PC 003

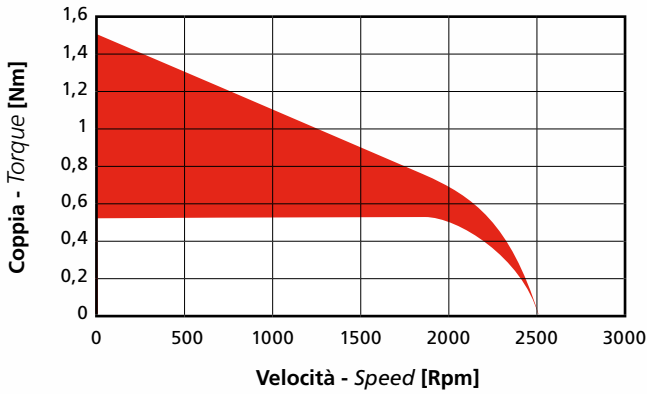

56 PC 013

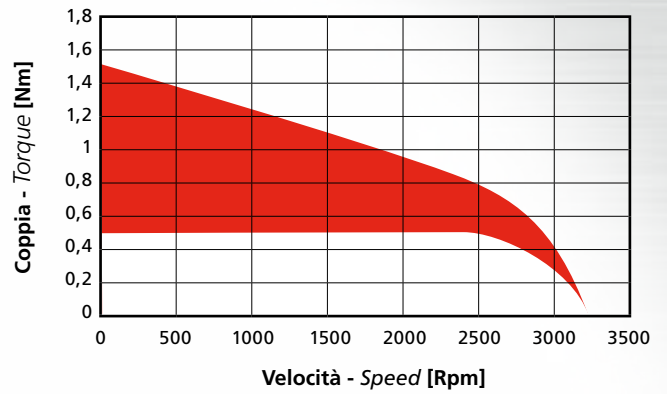

56 PC 042

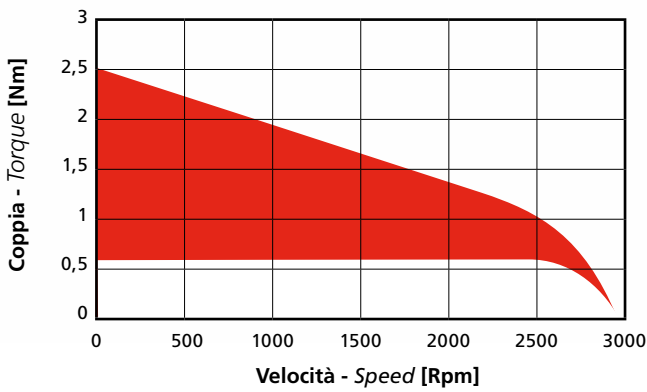

56 PC 043

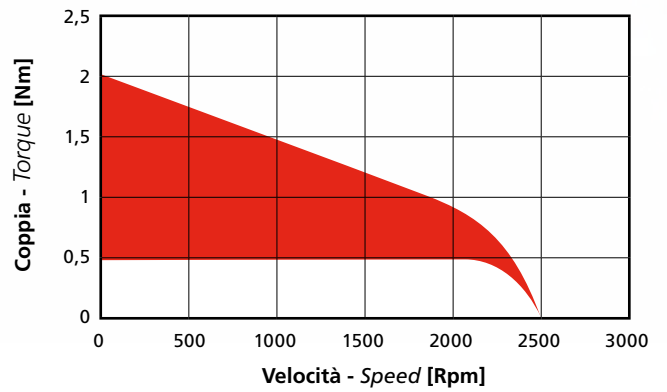

56 PM 004

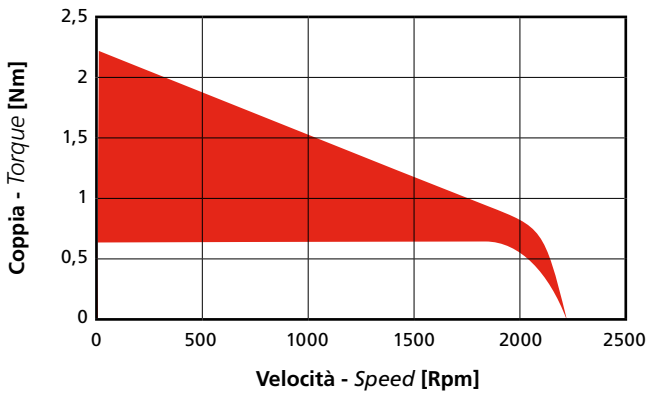

56 PM 014

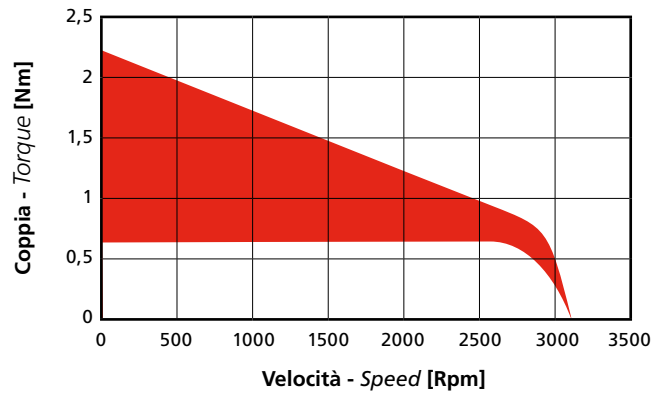

56 PM 034

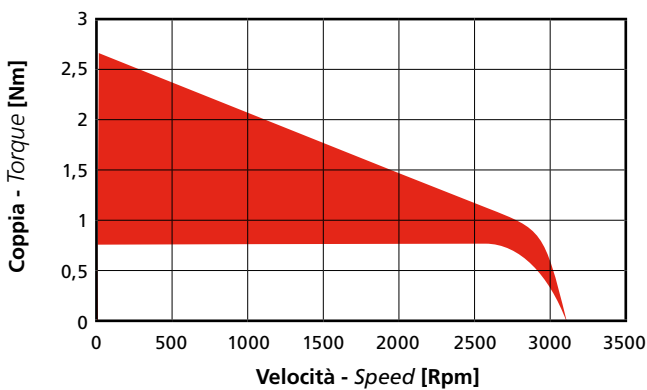

56 PM 044

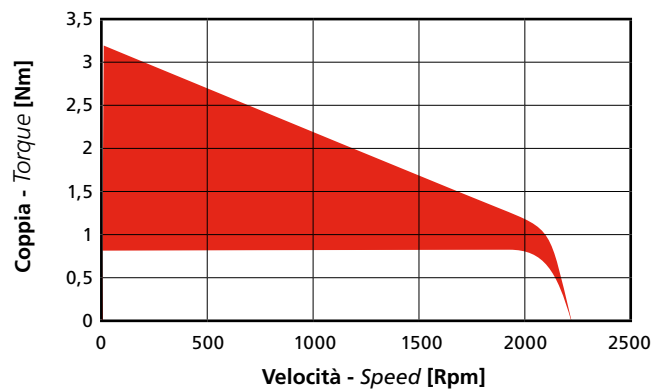

□ S1

■ S2, 30 min.

56 PM 112

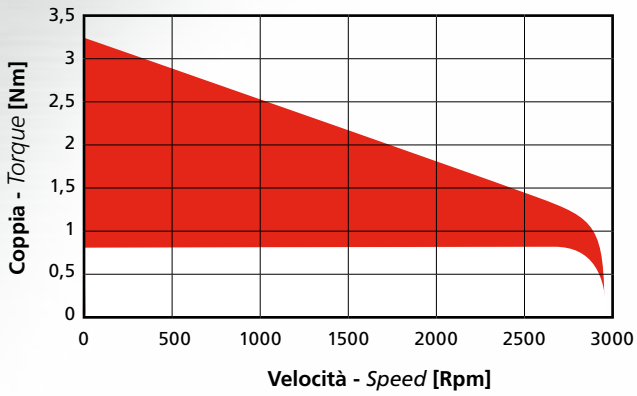

56 PM 118

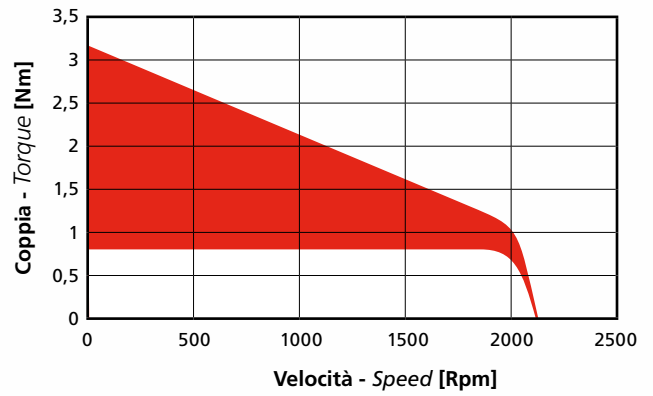

56 PL 005

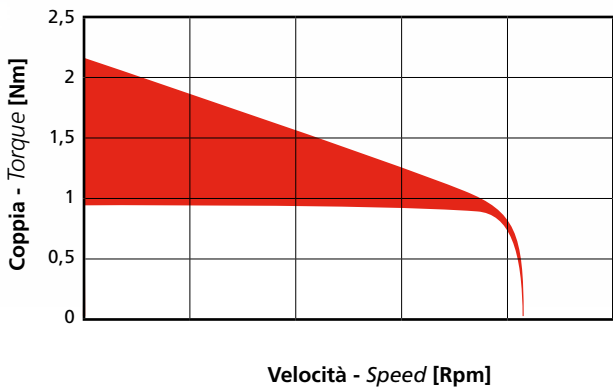

56 PL 015

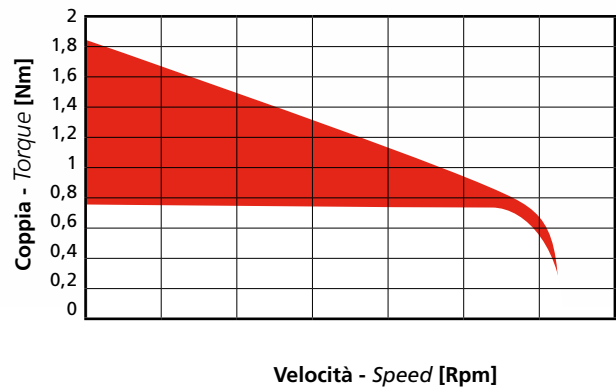

56 PL 046

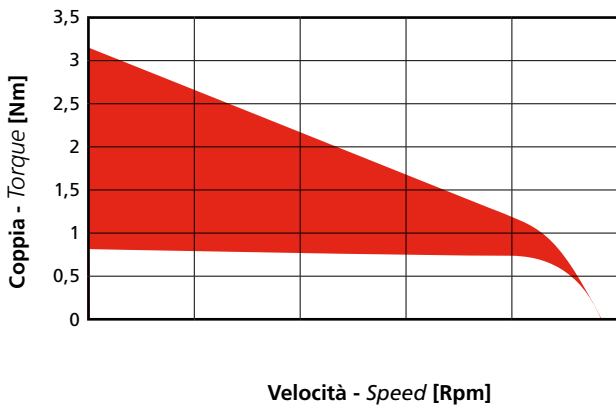

56 PL 054

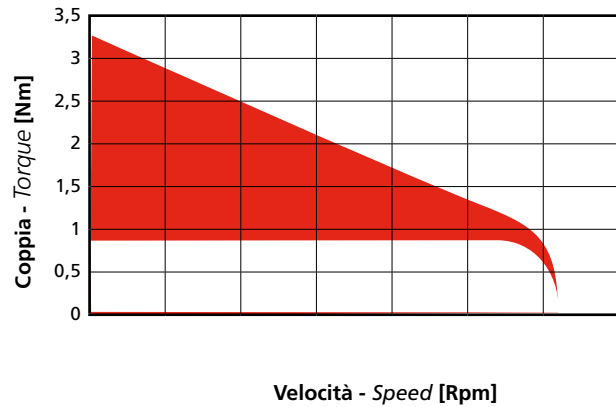

□ S1

■ S2, 30 min.

Serie 65 P

65 P Series

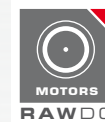

CARATTERISTICHE GENERALI - GENERAL CHARACTERISTICS

Tipo Type		65/75PC				65/75PM				75PL		
Tensione Nominale Rated Voltage	V	65				65				90	90	
Velocità Nominale Rated Speed	Rpm	1300	1850	2600	3700	1400	1850	2900	3700	2700	2750	1800
Potenza Nominale Rated Power	W	116	159	177	167	205	256	273	356	328	374	377
Codice di Avvolgimento Winding Code		131	132	133	134	135	136	137	138*	143	130	144

CARATTERISTICHE TECNICHE - TECHNICAL CHARACTERISTICS

Coppia Continuativa di Stallo Continuous Stall Current	Nm	1,05	1,15	1	0,85	1,7	1,7	1,45	1,85	1,8	2,2	2,7
Corrente Continuativa di Stallo Continuous Stall Torque	A	3	4,6	5,8	6,5	5,2	6,8	7,2	13	7,4	8,7	7
Coppia Nominale Rated Torque	Nm	0,85	0,82	0,65	0,43	1,4	1,32	0,90	0,92	1,16	1,30	2,0
Corrente Nominale Rated Current	A	2,1	2,7	4	3,6	3,7	4,6	4,9	6,5	4,0	4,5	5
Coppia di Picco allo Spunto Start Peak Torque	Nm	3,9	4,6	4	3,4	6,8	6,8	5,8	5,8	7,2	9	11
Corrente di Picco Start Peak Torque	A	11	18,5	23	26	21	27	34	46	30	35	28
Resistenza Totale Total Resistance	Ω	4,31	2,25	1,07	0,63	2,12	1,21	0,71	0,52	1,12	0,75	1,25
Induttanza Inductance	mH	9,68	5,31	2,4	1,44	4,52	2,4	1,22	0,68	2,59	1,64	3,55
Costante di Coppia Torque Constant	Nm/A	0,347	0,250	0,172	0,131	0,327	0,250	0,169	0,140	0,243	0,253	0,386
Costante di Tensione Voltage Constant	V/10 ³ Rpm	40,5	30	19,5	15	40,5	29,5	20	17	30	28,5	45
Costante di Tempo Elettrica Electrical Time Constant	ms	2,2	2,4	2,2	1,1	2,1	2,0	1,7	1,3	2,3	2,2	2,8

DATI MECCANICI - MECHANICAL DATA

Momento di Inerzia Moment of Inertia	Kg.m ²	3,9·10 ⁻⁴				7·10 ⁻⁴				8,5·10 ⁻⁴	
Massa Mass	Kg	3,1				5,0				6,8	
Massimo Carico Radiale Maximum Radial Load	N	370				380				380	
Massimo Carico Assiale Maximum Axial Load	N	100				110				110	

CARATTERISTICHE TERMICHE - THERMAL CHARACTERISTICS

Temperatura di Funzionamento Rated Temperature	°C	0 ÷ 40 °C										
Classe di Isolamento Type of Insulation		F										
Grado di Protezione Level of Protection		IP44										
Montaggio Mounting		In Aria / Free Still Air										

Dati rilevati a temperatura ambiente di 25° C e con temperatura massima del collettore di 115°C.
The data was obtained at a room temperature of 25 °C with 115°C on the commutator.

Servomotore - Servomotor

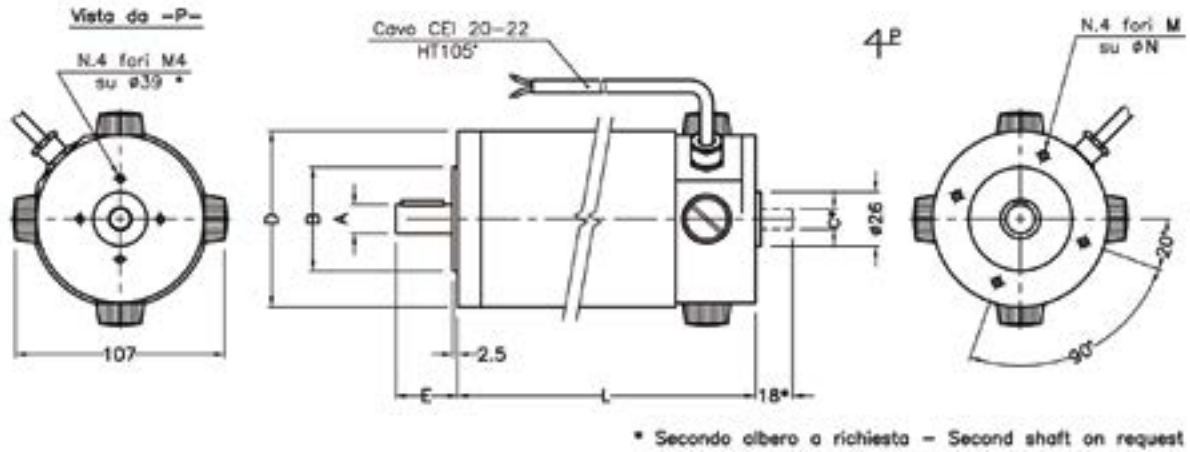

Servomotore con dinamo tachimetrica - Tacho servomotor

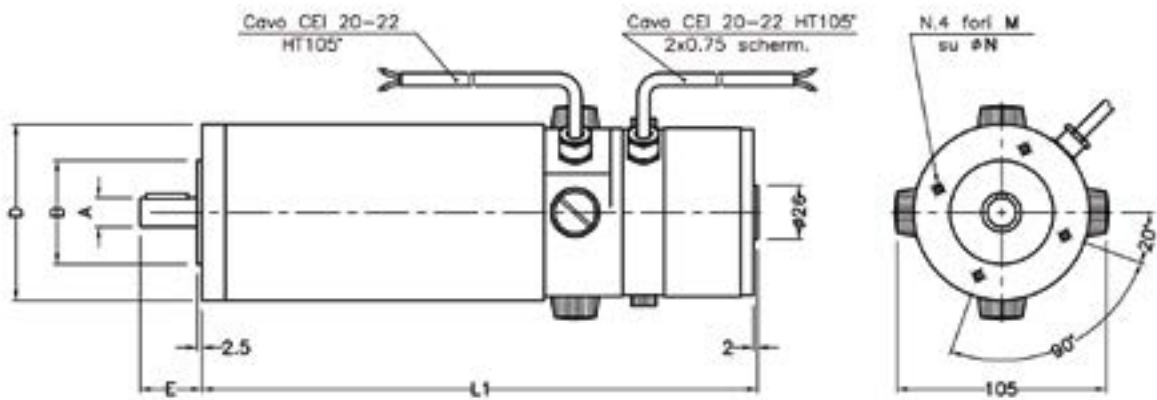

Servomotore con freno - Servomotor with brake

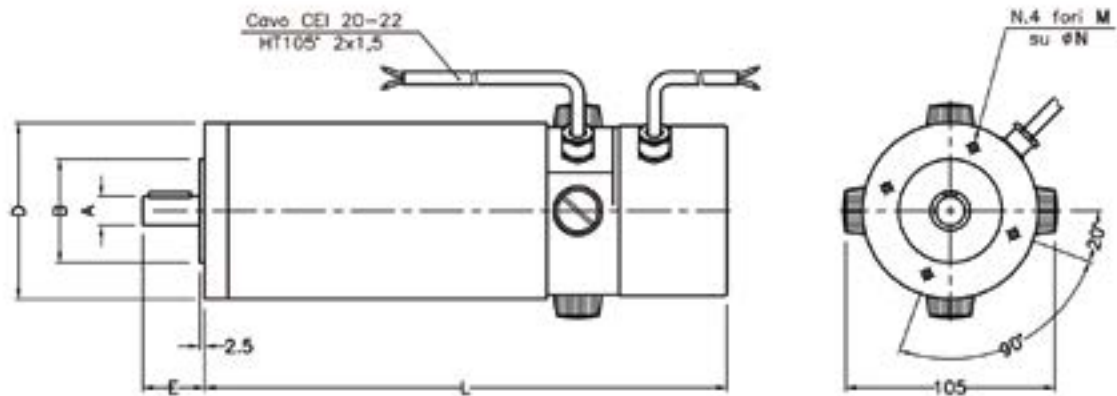

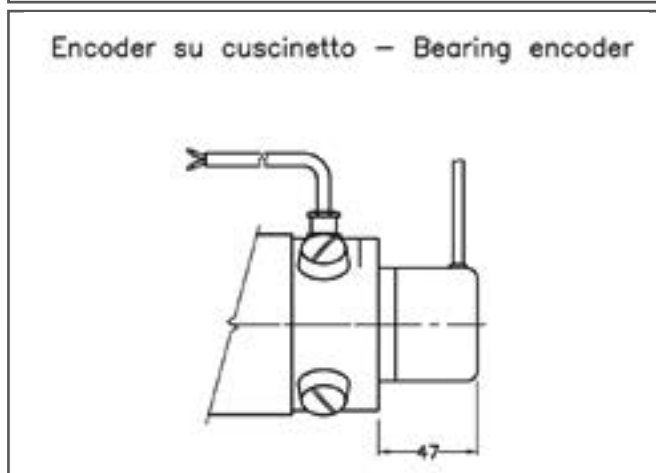
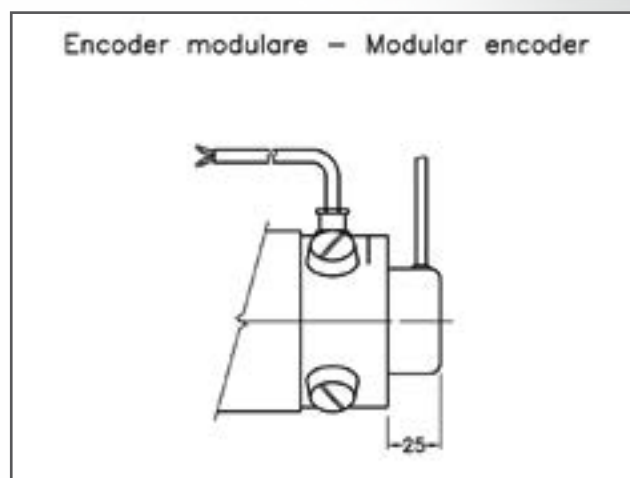
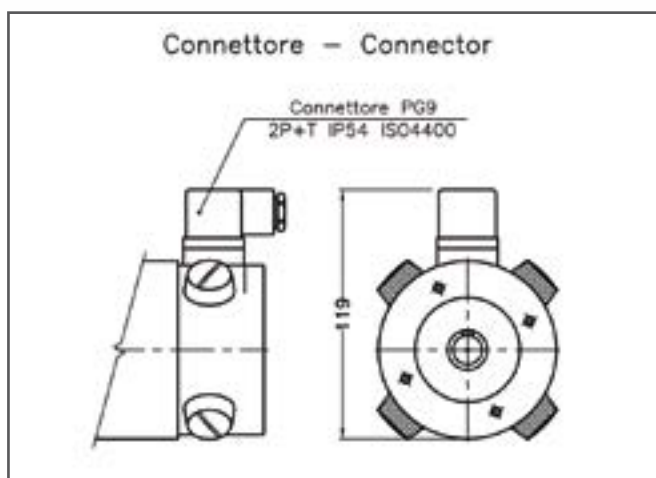

DIMENSIONI - DIMENSIONS

Taglia Size	Tipo di Flangia Flange type	A ^{h6}	B ^{h7}	C ^{h6}	D	E ^{±0,2}	L ^{±0,5}	L1 ^{±0,5}	M	N	Linguetta Key		
65PC	56B14	11	50	10	84	23	146	208	M5	65	4X4X15		
		14				30					5X5X20		
	63B14	11	60	10	90	23			M5	75	4X4X15		
	71B14	14	70	10	105	30					M6	85	5X5X20
	63B5	11	95	10	140	23					8,5	115	4X4X15
71B5	14	110	10	160	30	8,5	130	5X5X20					
65PM	56B14	11	50	10	84	23	206	268	M5	65	4X4X15		
		14				30					5X5X20		
	63B14	11	60	10	90	23			M5	75	4X4X15		
	71B14	14	70	10	105	30					M6	85	5X5X20
	63B5	11	95	10	140	23					8,5	115	4X4X15
71B5	14	110	10	160	30	8,5	130	5X5X20					
65PL	56B14	11	50	10	84	23	268	330	M5	65	4X4X15		
		14				30					5X5X20		
	63B14	11	60	10	90	23			M5	75	4X4X15		
	71B14	14	70	10	105	30					M6	85	5X5X20
	63B5	11	95	10	140	23					8,5	115	4X4X15
71B5	14	110	10	160	30	8,5	130	5X5X20					

Per servomotori con freno di stazionamento, le quote L e L1 devono essere aumentate di 46 mm
 For servomotors with brake, the measurements L and L1 need to be increased by 46 mm.



Caratteristiche Coppia-Velocità

Torque-Speed characteristics

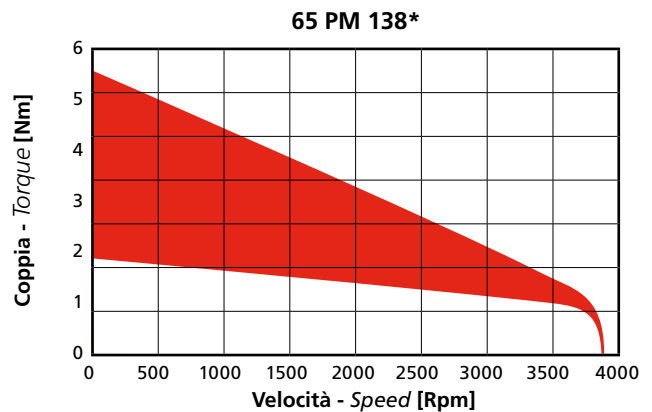
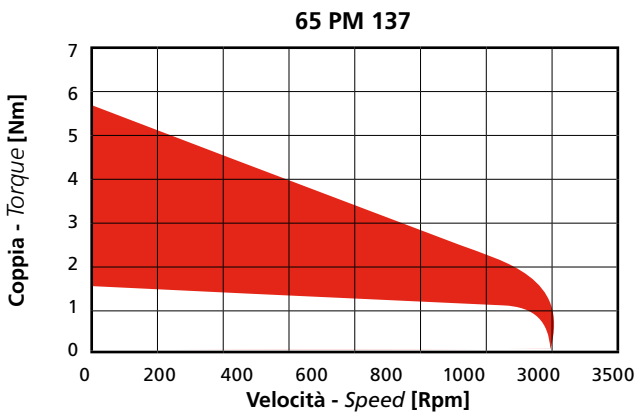
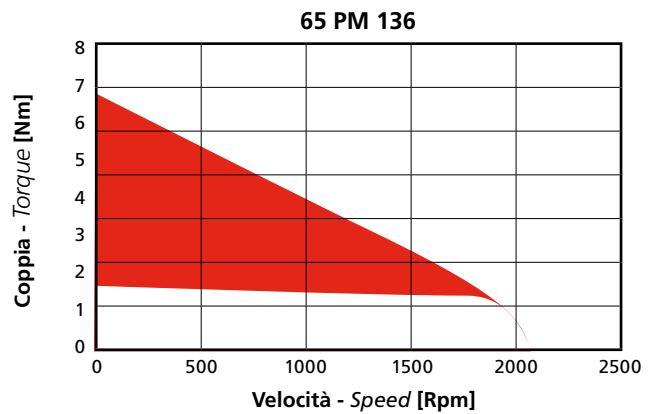
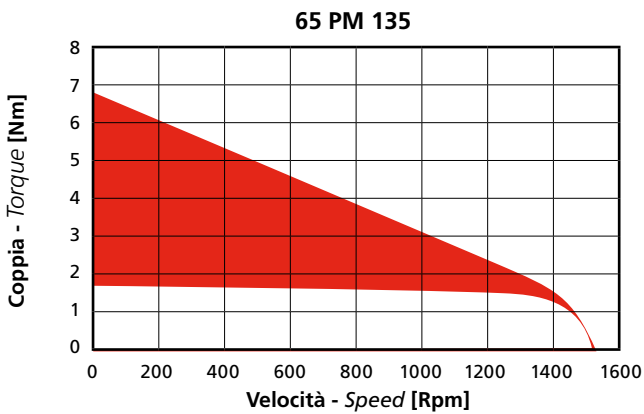
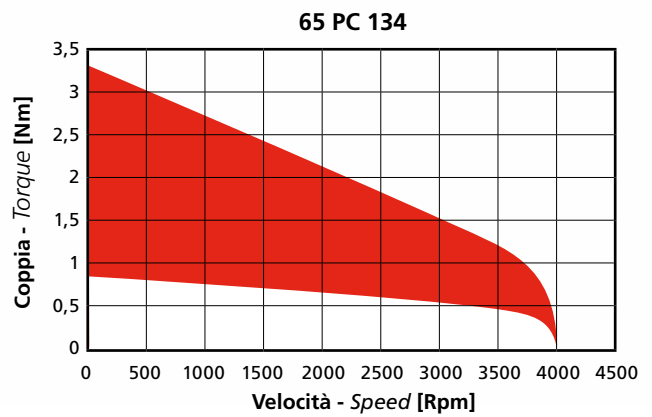
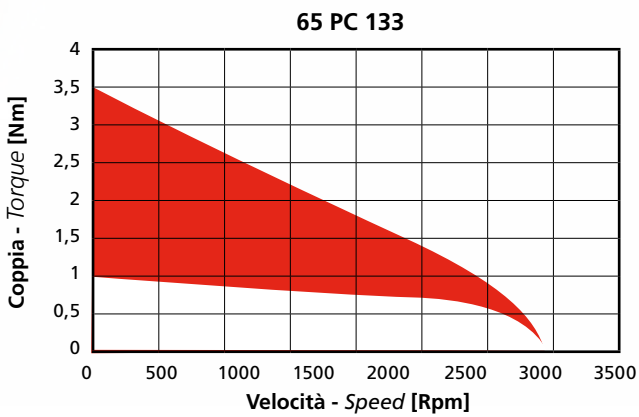
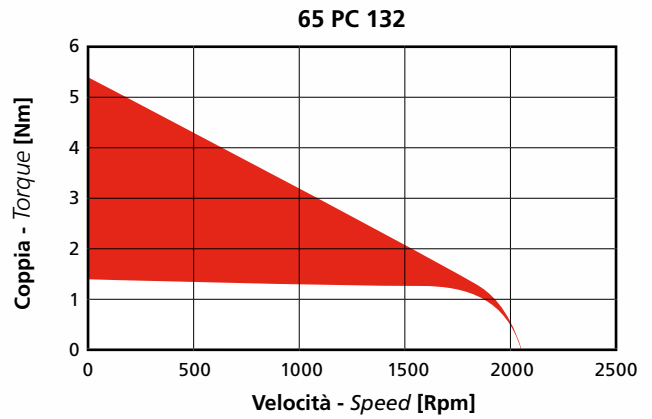
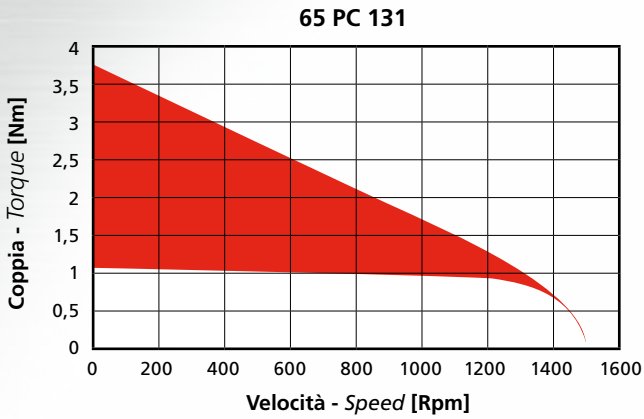

□ S1

■ S2, 30 min.

* Servizio limitato S2-30'
Limited duty S2-30'

65 PM 143

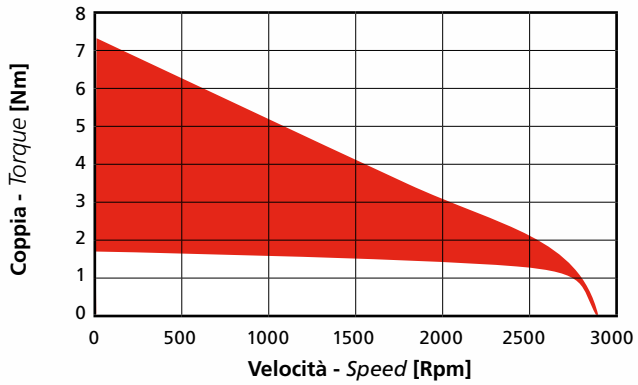

65 PL 130

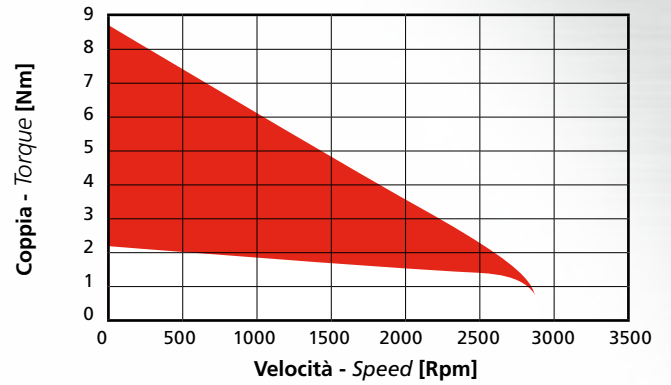

65 PL 144

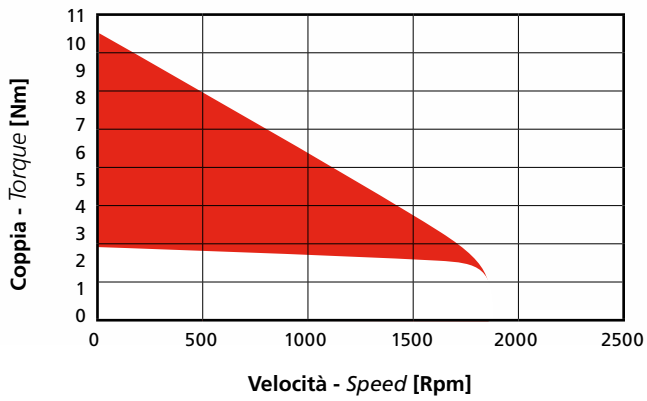

□ S1

□ S2, 50% 30 min.



Dinamo Tachimetriche a Magneti Permanenti

Permanent Magnet Tacho Generators

Caratteristiche Generali

- Temperatura ambiente: 25°C.
- Magneti permanenti
- Temperatura ambiente di funzionamento: 0 - 40 °C
- Isolamento: classe F
- Grado di protezione: IP 44
- Massima velocità: 6000 rpm
- Costruzione e collaudo in conformità alle norme IEC

General Characteristics

- Test ambient temperature: 25°C
- Ferrite permanent magnets
- Working ambient temperature: 0 - 40 °C
- Insulation: class F
- Type of protection: IP44
- Maximum speed: 6000 rpm
- Construction and test in conformity with IEC standards

CARATTERISTICHE TERMICHE - THERMAL CHARACTERISTICS

Codice Code		DT03	DT/AS 7,5	DT/AS 10	DT/AS 14	TG 10
Gradiente di Tensione (±5%) Voltage Gradient	V/1000 Rpm	3	7,5	10	14	10
Ripple Massimo (Picco - Picco) Ripple (Max: peak-peak)	%	6	6	7	7	2
Linearità (Massima Deviazione) Linearity (Maximum Deviation)	%	0,35	0,15	0,25	0,3	0,2
Corrente Massima Erogabile Max Output Current	mA	30	30	30	30	50
Resistenza Totale Total Resistance	Ω	20,7	31,7	45,8	79,2	26,5
Induttanza Inductance	mH	7,09	11,6	20,3	38,8	27,1
Coefficiente di Temperatura Temperature Coefficient	%/°C	-0,09	-0,08	-0,06	-0,08	-0,09
Costante di Tempo Elettrica Electrical Time Constant	ms	0,34	0,37	0,44	0,49	1,00
Momento di Inerzia Moment of Inertia	Kg.m ²	1,5E-06	5,7E-06	5,7E-06	5,7E-0,6	8,0E-0,5
Massa Mass	Kg	0,2	0,4	0,4	0,4	0,8

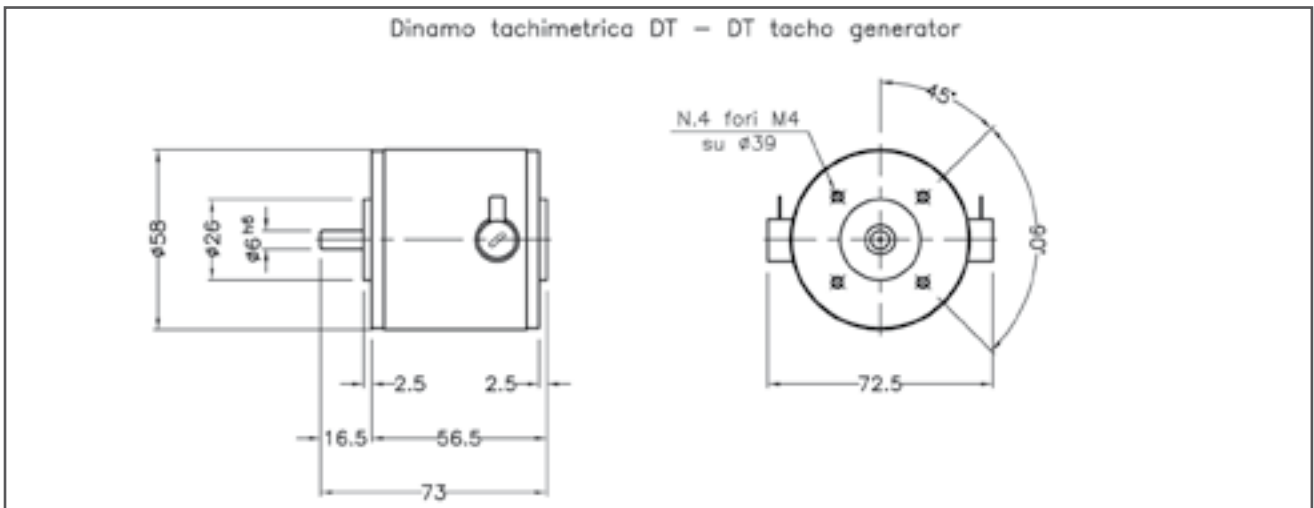
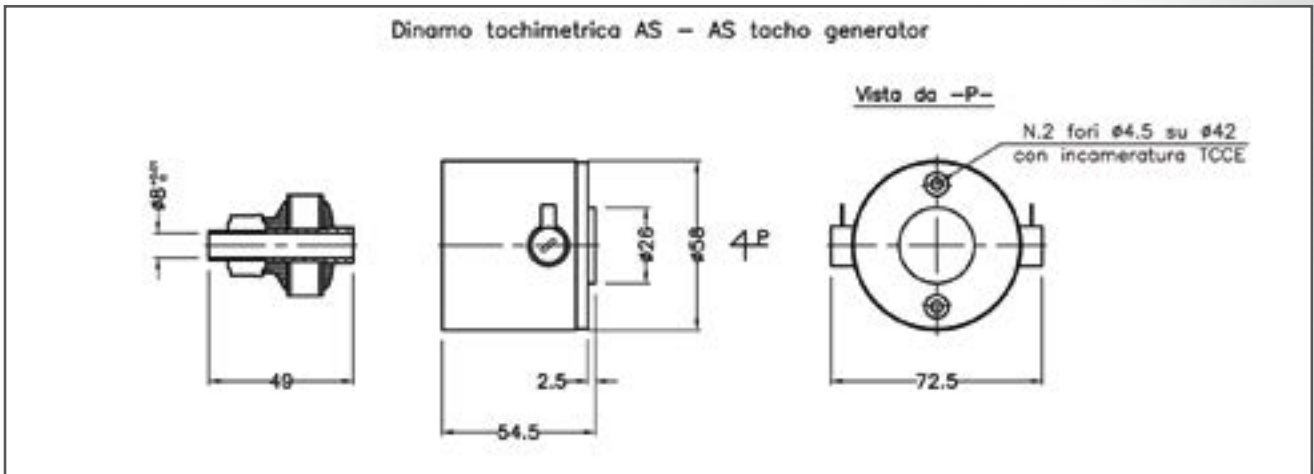

Tolleranze sulle dimensioni angolari : $\pm 5^\circ$
 The tolerance on angular dimensions: $\pm 5^\circ$

Opzionali

Optionals

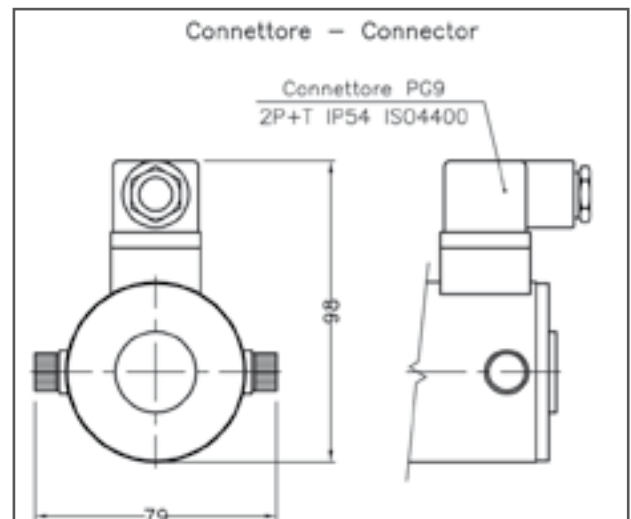
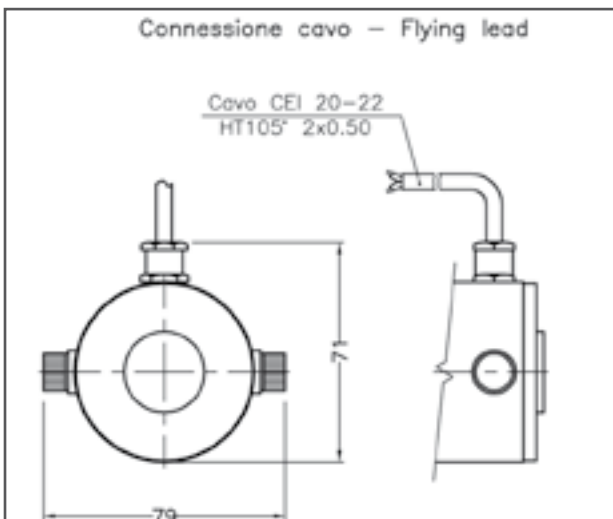

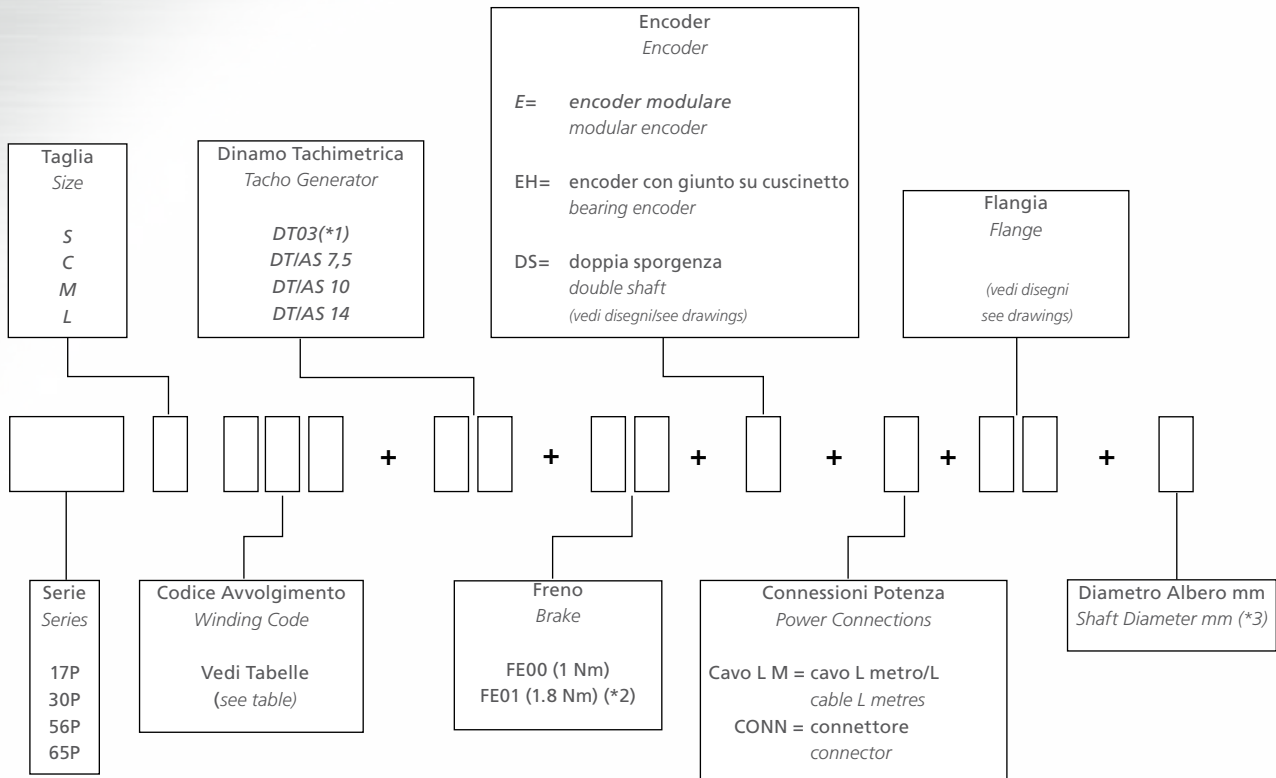

(*1) Disponibile solo per la serie 17 P
Available only for 17 P series.

(*2) Disponibile solo per la serie 56/63 P e 65/75 P.
Available only for 56/63 P and 65/75 P series.

(*3) Nelle serie 56/63 P e 65/75 P è possibile avere motori con flangiature ibride (es. PAM 56B14 con albero $\varnothing = 11$ mm)
56/63 P and 65/75 P are available with mixed coupling system (eg. PAM 56B14 flange and $\varnothing = 11$ mm shaft)

Tipo Encoder Encoder Type	Conteggio Count	ppr	Canali Channels	Logica Logic	Alimentazione Power Supply
E	Incrementale Incremental	4 ÷ 1000	A,B,Z	Push Pull line driver	5 Vdc / 8 ÷ 24 Vdc
EH	Incrementale Incremental	4 ÷ 2000	A,B,Z	Push Pull line driver	

Esempio di designazione

56 PC 003 + DT10 + FE01 + E + CONN + 56B14 + 11

Questa designazione definisce un motore con le seguenti caratteristiche:

- Serie 56
- Taglia PC
- Codice di avvolgimento 003 (vedi tabelle)
- Dinamo tachimetrica 10V/1000 rpm
- Freno di coppia nominale di 1,8 Nm
- Encoder modulare
- Connettore di potenza
- Flangia 56B14
- Diametro dell'albero 11 mm

Purchasing example

56 PC 003 + DT10 + FE01 + E + CONN + 56B14 + 11

This code represents the following motor:

- Series 56
- Size PC
- Winding code 003 (see table)
- Tacho generator 10 V/1000 rpm
- Brake with rated torque 1.8 Nm
- Modular encoder
- Power connector
- Flange type 56B14
- Shaft diameter 11 mm







Terre rare



Rinnovata serie di motori studiati per offrire le potenze specifiche più elevate oggi disponibili sul mercato dei servomotori c.c..

Le elevate competenze aziendali e nuovi strumenti di calcolo computerizzato 3D (software FEA) hanno permesso di realizzare il massimo risultato possibile dall'impiego dei magneti permanenti in Terre Rare.

Questo prodotto riunisce in sé:

- Eccellenti potenze specifiche
- Elevate linearità di rotazione
- Inerzie contenute

This dc permanent magnet motor series has been revised so as to offer the highest specific power available in the market for such motors.

The vast experience that the company has acquired in the dc permanent magnet motor field combined with new design tools such as 3D FEA software, has allowed the optimisation of the performance of the Rare Earth magnets, resulting in:

- *Excellent specific power*
- *Maintained high constant torque*
- *Low inertia*

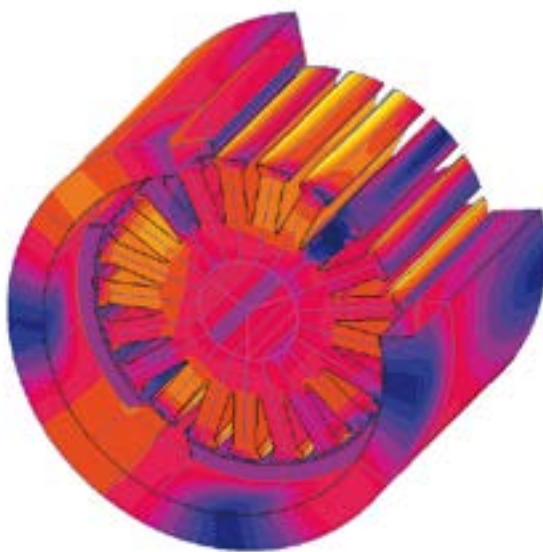

Modello FEA 3D di servomotore a magneti permanenti in Terre Rare che mostra l'andamento dell'induzione magnetica ed il reticolo di calcolo.

3D FEA model of a dc Rare Earth servomotor showing the magnetic induction and the mesh used in the calculations.

SPECIFICHE TECNICHE STANDARD

SPECIFICATIONS OF STANDARD MODELS



Tipo Servomotori a corrente continua a magneti permanenti

Type *Permanent magnet brushed motors*

Statore A magneti permanenti in Terre rare sinterizzati, incollati e protetti con anello in acciaio INOX

Stator *Rare earth permanent magnets mechanically fastened*

Isolamento Motore e avvolgimento in classe F secondo DIN 0530

Insulation *Motor and winding in class F in accordance with DIN 0530*

Cuscinetti Cuscinetti di alta qualità lubrificati a vita, bloccato anteriormente

Bearings *High quality, life lubricated, front bearing locked*

Raffreddamento Convezione naturale IC0041

Cooling *Natural convection IC0041*

Grado di Protezione IP44

Level of Protection *IP44*

Opzioni disponibili

Available options

Trasduttore di Posizione Encoder incrementale risoluzione a richiesta

Position sensor *Incremental encoder*

Freno di sicurezza Coppia frenante > Coppia nominale motore

Safety brake *Holding torque > Rated torque of the electric motor*

Alimentazione Cavo uscente su pressacavo, connettore tipo elettrovalvola IP55

Power supply *Cable, IP55 connector*

Grado di Protezione IP 55

Level of Protection *IP55*



Serie N17

N17 Series

CARATTERISTICHE GENERALI - GENERAL CHARACTERISTICS

Tipo Type	N17L		
Tensione Nominale Rated Voltage	V	24	24
Velocità Nominale Rated Speed	Rpm	2025	4000
Potenza Nominale Rated Power	W	23	38
Codice di Avvolgimento Winding Code		839	823

CARATTERISTICHE TECNICHE - TECHNICAL CHARACTERISTICS

Coppia Continuativa di Stallo (*) Continuous Stall Current (*)	Nm	0,12	0,11
Corrente Continuativa di Stallo (*) Continuous Stall Torque (*)	A	1,90	2,70
Coppia Nominale (*) Rated Torque (*)	Nm	0,11	0,09
Corrente Nominale (*) Rated Current (*)	A	1,70	2,60
Coppia di Picco allo Spunto Start Peak Torque	Nm	0,36	0,33
Corrente di Picco Start Peak Torque	A	5,70	8,10
Resistenza Totale Total Resistance	Ω	5,10	2,18
Induttanza Inductance	mH	2,50	0,85
Costante di Coppia Torque Constant	Nm/A	0,06	0,04
Costante di Tensione Voltage Constant	V/10 ³ Rpm	7,15	4,40
Costante di Tempo Elettrica Electrical Time Constant	ms	0,49	0,39
Costante di Tempo Termica Thermal Time Constant	min	21	16

DATI MECCANICI - MECHANICAL DATA

Momento di Inerzia Moment of Inertia	Kg·m ²	3,2E-06	
Massa Mass	Kg	0,58	
Massimo Carico Radiale Maximum Radial Load	N	90	
Massimo Carico Assiale Maximum Axial Load	N	50	

CARATTERISTICHE TERMICHE - THERMAL CHARACTERISTICS

Temperatura di Funzionamento Rated Temperature	°C	0 ÷ 40 °C	
Classe di Isolamento Type of Insulation		F	
Grado di Protezione Level of Protection		IP44	
Montaggio Mounting		Flangiato - Flanged (**)	

(*) Dati rilevati a temperatura ambiente di 25°C e con temperatura massima del collettore pari a 115 °C.
 (*) The data was obtained at a room temperature of 25 °C with 115 °C on the commutator.

(**) Flangia in acciaio 150x150x8 mm
 (***) Steel flange 150x150x8 mm

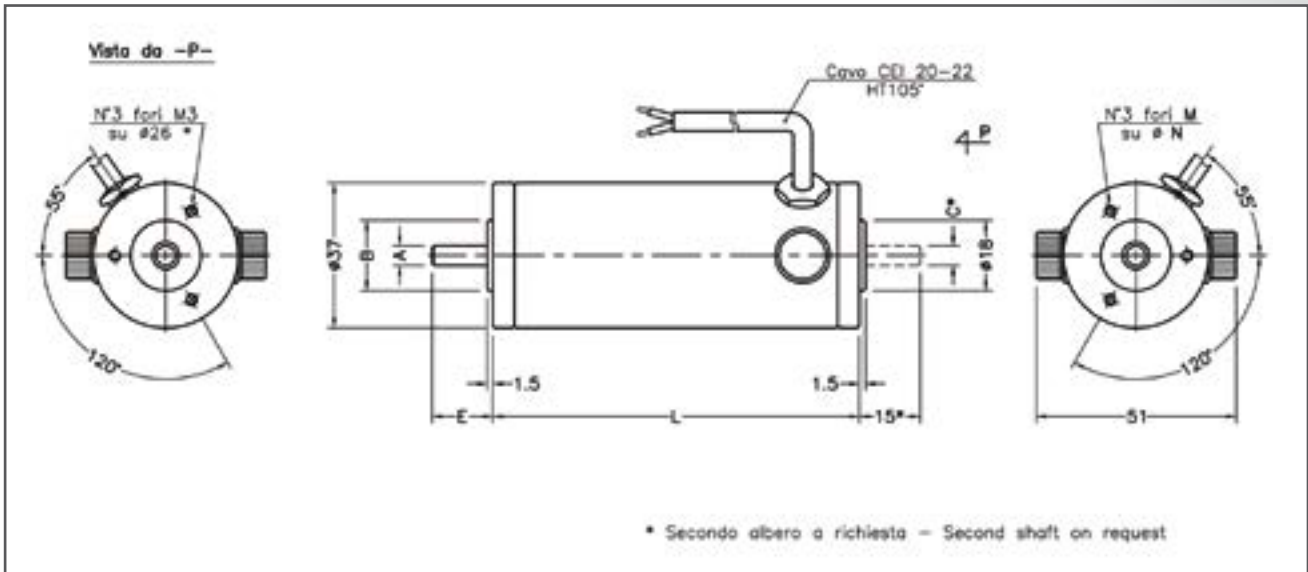

Tolleranze sulle dimensioni angolari : $\pm 5^\circ$
 The tolerance on angular dimensions: $\pm 5^\circ$

Opzionali

Optionals

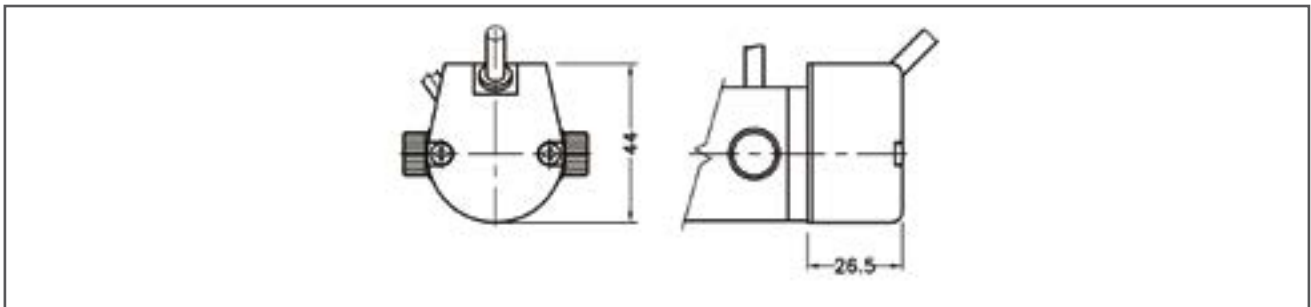

DIMENSIONI - DIMENSIONS

Taglia Size	Tipo di Flangia Flange type	A ^{h6}	B ^{h7}	C ^{h6}	L ^{±0.5}	M	N
N17L	Standard	5	18	6	93,5	M3	26



Caratteristiche Coppia-Velocità

Torque-Speed characteristics

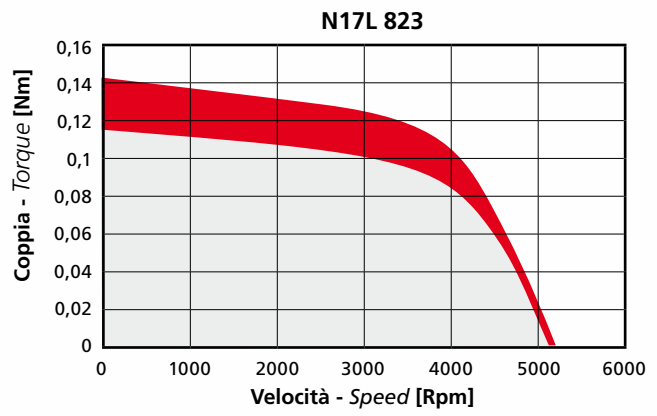
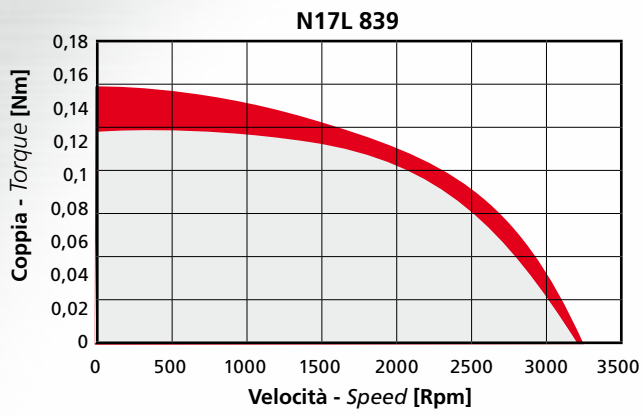

■ S1

■ S2, 30 min.

CARATTERISTICHE GENERALI - GENERAL CHARACTERISTICS

Tipo Type		N45C	N45M				N45ML	
Tensione Nominale Rated Voltage	V	24	24	32	48	75	24	48
Velocità Nominale Rated Speed	Rpm	3060	2750	3010	3260	3100	2700	3080
Potenza Nominale Rated Power	W	77	115	126	137	136	164	184
Codice di Avvolgimento Winding Code		984	970	980	630	105	697	691

CARATTERISTICHE TECNICHE - TECHNICAL CHARACTERISTICS

Coppia Continuativa di Stallo (*) Continuous Stall Current (*)	Nm	0,26	0,44	0,44	0,45	0,45	0,64	0,65
Corrente Continuativa di Stallo (*) Continuous Stall Torque (*)	A	4,65	6,20	5,20	3,70	2,30	8,40	5,00
Coppia Nominale (*) Rated Torque(*)	Nm	0,24	0,40	0,40	0,40	0,42	0,58	0,57
Corrente Nominale (*) Rated Current (*)	A	4,50	6,10	5,10	3,45	2,20	8,15	4,65
Coppia di Picco allo Spunto Start Peak Torque	Nm	0,78	1,32	1,32	1,35	1,35	1,92	1,95
Corrente di Picco Start Peak Torque	A	13,95	18,60	15,60	11,10	6,90	25,20	15,00
Resistenza Totale Total Resistance	Ω	1,11	0,57	0,85	1,56	3,70	0,43	1,05
Induttanza Inductance	mH	0,50	0,30	0,47	1,00	2,50	0,21	0,67
Costante di Coppia Torque Constant	Nm/A	0,06	0,07	0,08	0,12	0,20	0,08	0,13
Costante di Tensione Voltage Constant	V/10 ³ Rpm	6,16	7,45	9,23	13,10	21,10	7,80	13,85
Costante di Tempo Elettrica Electrical Time Constant	ms	0,45	0,53	0,55	0,64	0,68	0,49	0,64
Costante di Tempo Termica Thermal Time Constant	min	20	21	21	19	20	23	18

DATI MECCANICI - MECHANICAL DATA

Momento di Inerzia Moment of Inertia	Kg·m ²	2,1E-5	4,0E-5				5,4E-5	
Massa Mass	Kg	0,76	1,15				1,48	
Massimo Carico Radiale Maximum Radial Load	N	100	200				200	
Massimo Carico Assiale Maximum Axial Load	N	40	70				70	

CARATTERISTICHE TERMICHE - THERMAL CHARACTERISTICS

Temperatura di Funzionamento Rated Temperature	°C	0 ÷ 40 °C						
Classe di Isolamento Type of Insulation		F						
Grado di Protezione Level of Protection		IP44						
Montaggio Mounting		Flangiato - Flanged (**)						

(*) Dati rilevati a temperatura ambiente di 25°C e con temperatura massima del collettore pari a 115 °C.
 (*) The data was obtained at a room temperature of 25 °C with 115 °C on the commutator.

(**) Flangia in acciaio 150x150x8 mm
 (***) Steel flange 150x150x8 mm

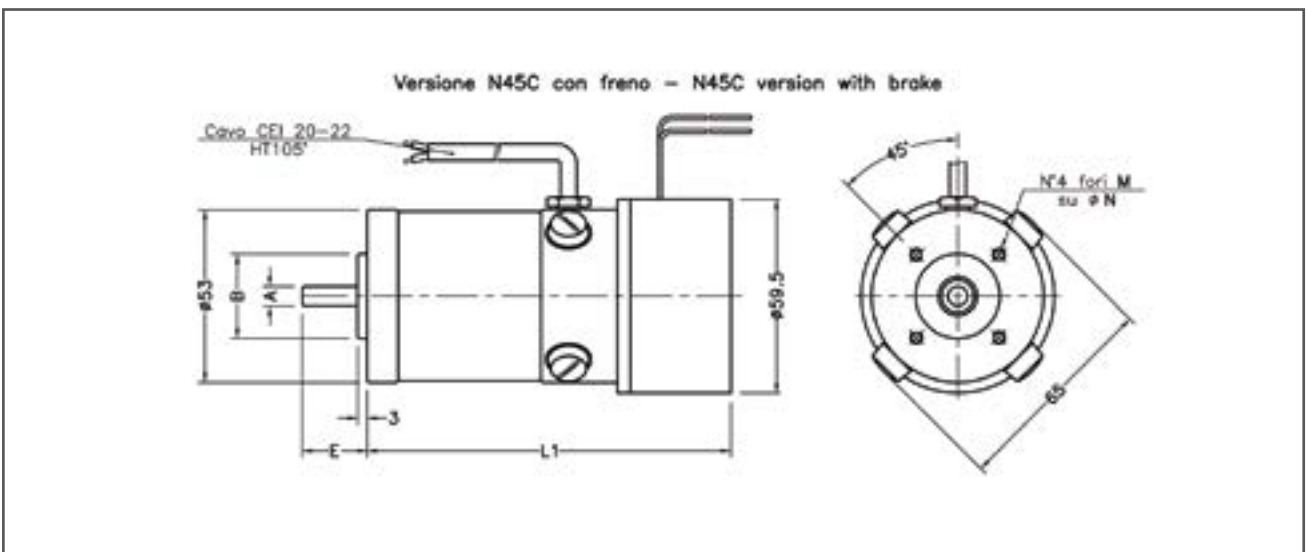
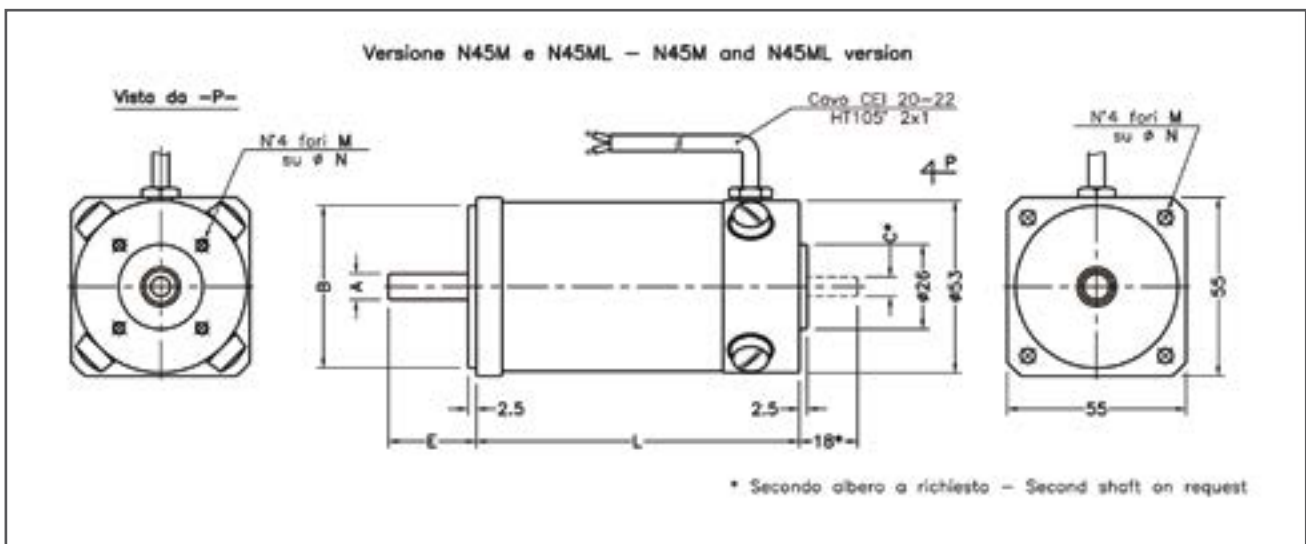
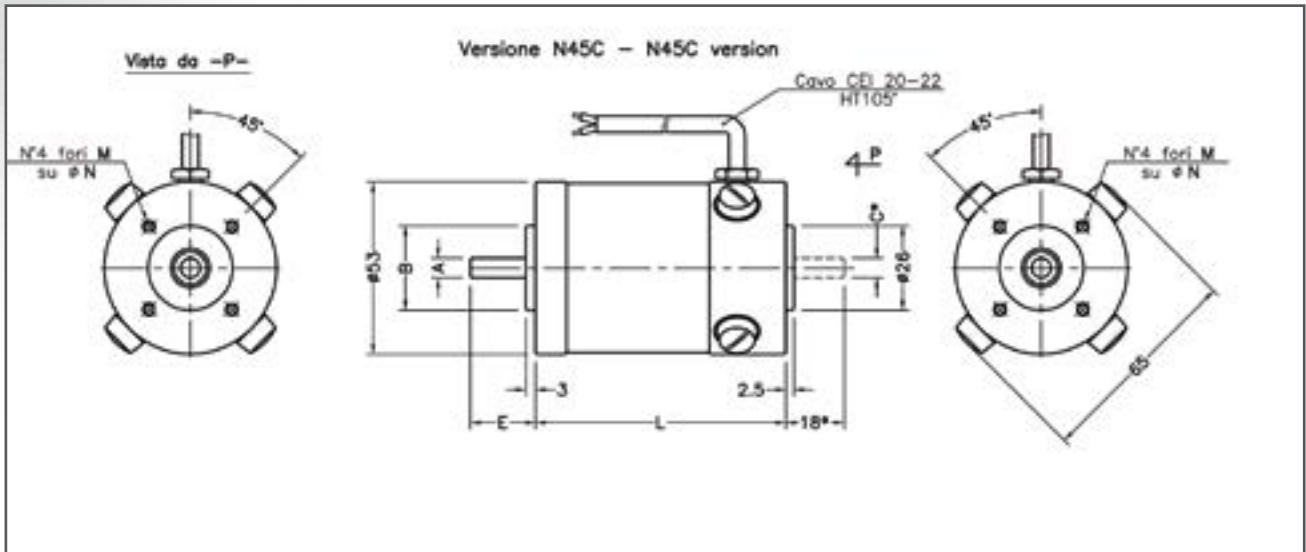

Tolleranze sulle dimensioni angolari : $\pm 5^\circ$
 The tolerance on angular dimensions: $\pm 5^\circ$

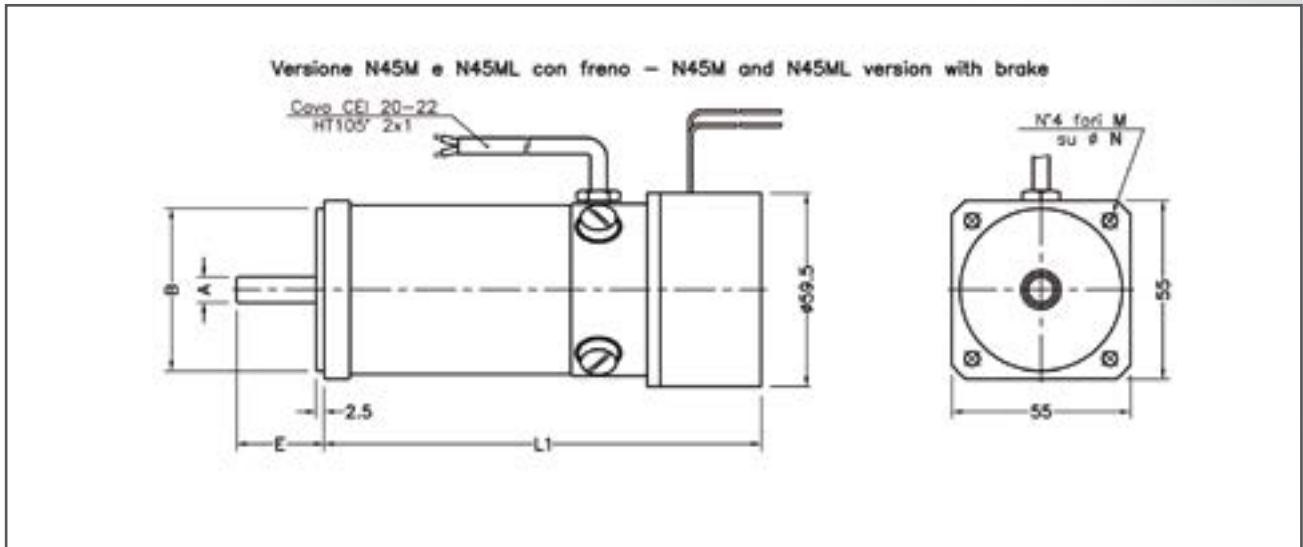

Opzionali

Optionals

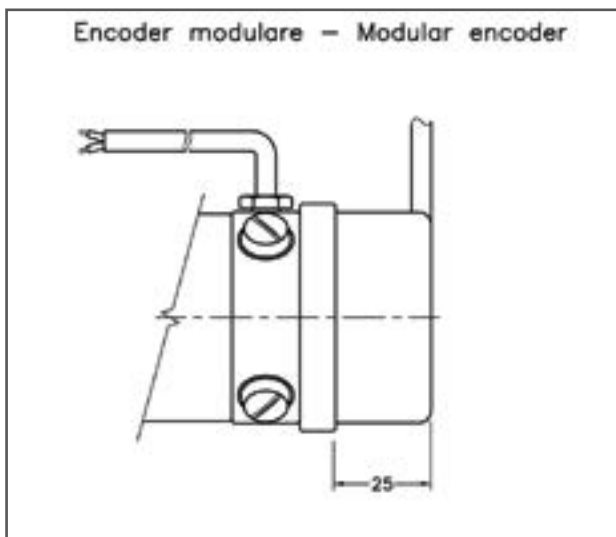

DIMENSIONI - DIMENSIONS

Taglia Size	Tipo di Flangia Flange type	A ^{h6}	B ^{h7}	C ^{h6}	E ^{±0,2}	L ^{±0,5}	L1 ^{±0,5}	M	N
N45C	Standard	6	25	6	20	77	112	M4	36
N45M	Standard	8	50	6	27	99,5	134,5	4,5	60
N45ML	Standard	8	50	6	27	123,5	158,5	4,5	60

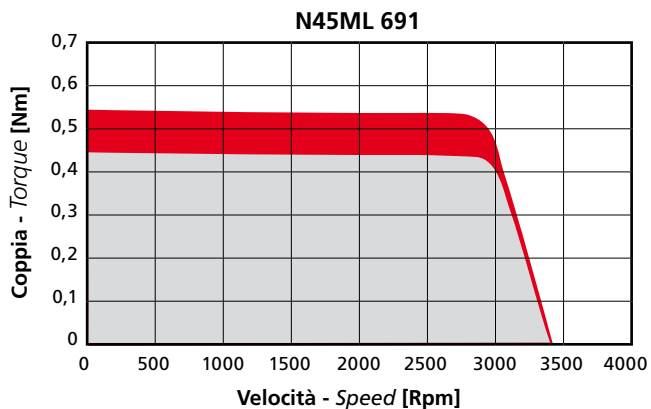
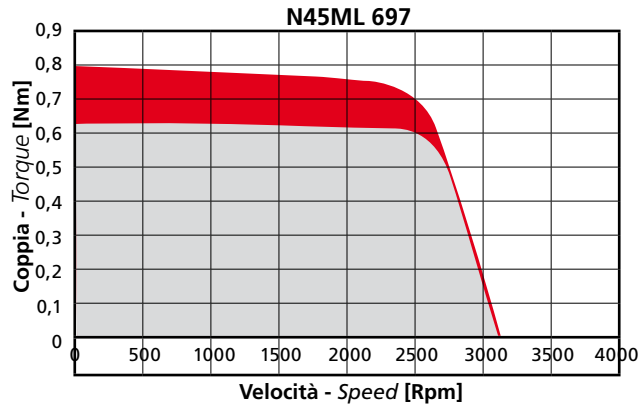
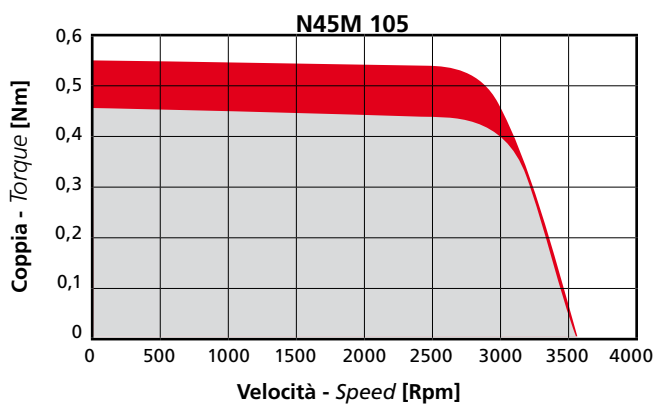
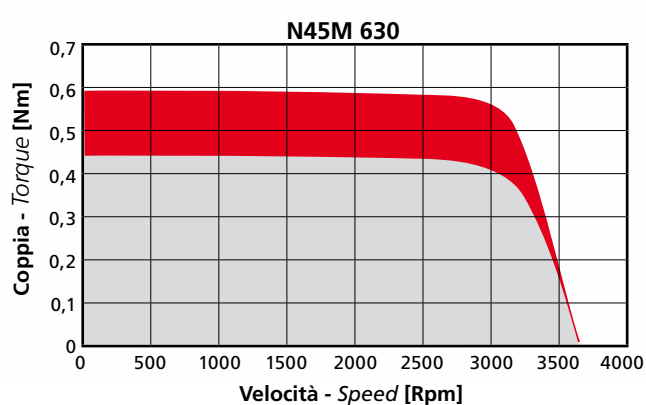
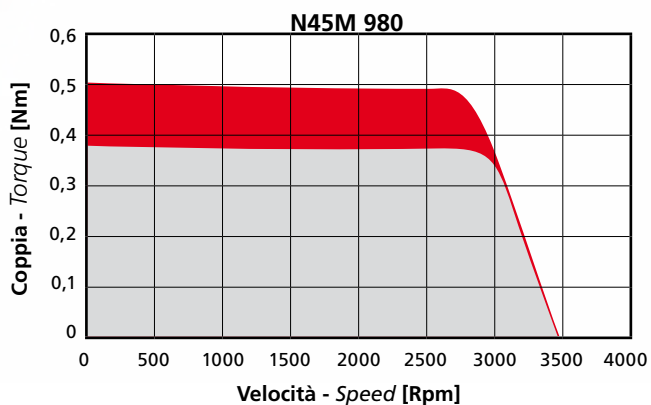
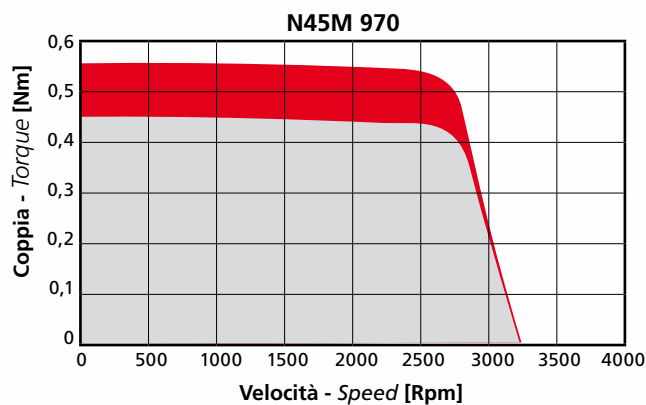
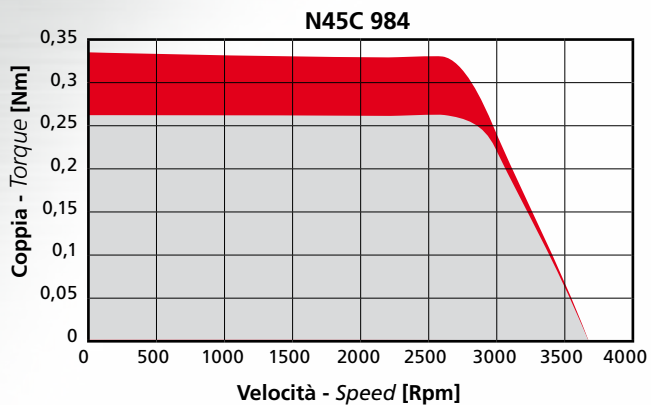

CARATTERISTICHE GENERALI - GENERAL CHARACTERISTICS

Tipo Type		N70C				N70M	
Tensione Nominale Rated Voltage	V	24	24	42	48	48	90
Velocità Nominale Rated Speed	Rpm	1900	3150	2900	2200	2800	3200
Potenza Nominale Rated Power	W	185	247	237	184	408	442
Codice di Avvolgimento Winding Code		723	724	714	721	771	775

CARATTERISTICHE TECNICHE - TECHNICAL CHARACTERISTICS

Coppia Continuativa di Stallo (*) Continuous Stall Current (*)	Nm	1,03	0,93	0,95	1,00	1,90	1,90
Corrente Continuativa di Stallo (*) Continuous Stall Torque (*)	A	10,00	14,50	7,20	5,50	12,60	7,30
Coppia Nominale (*) Rated Torque(*)	Nm	0,93	0,75	0,78	0,80	1,39	1,32
Corrente Nominale (*) Rated Current (*)	A	9,40	12,50	6,40	4,65	9,50	5,50
Coppia di Picco allo Spunto Start Peak Torque	Nm	3,09	2,79	2,85	3,00	5,70	5,70
Corrente di Picco Start Peak Torque	A	30,00	43,50	21,60	16,50	37,80	21,90
Resistenza Totale Total Resistance	Ω	0,38	0,29	0,48	0,91	0,39	0,95
Induttanza Inductance	mH	0,35	0,14	0,55	1,05	0,34	0,90
Costante di Coppia Torque Constant	Nm/A	0,10	0,06	0,13	0,18	0,15	0,26
Costante di Tensione Voltage Constant	V/10 ³ Rpm	11,06	6,90	13,80	19,90	16,65	27,70
Costante di Tempo Elettrica Electrical Time Constant	ms	0,92	0,48	1,15	1,15	0,87	0,95
Costante di Tempo Termica Thermal Time Constant	min	35	25	26	25	37	44

DATI MECCANICI - MECHANICAL DATA

Momento di Inerzia Moment of Inertia	Kg·m ²	1,6E-4				3,3E-4	
Massa Mass	Kg	2,3				3,6	
Massimo Carico Radiale Maximum Radial Load	N	300				330	
Massimo Carico Assiale Maximum Axial Load	N	80				80	

CARATTERISTICHE TERMICHE - THERMAL CHARACTERISTICS

Temperatura di Funzionamento Rated Temperature	°C	0 ÷ 40 °C					
Classe di Isolamento Type of Insulation		F					
Grado di Protezione Level of Protection		IP44					
Montaggio Mounting		Flangiato - Flanged (**)					

(*) Dati rilevati a temperatura ambiente di 25°C e con temperatura massima del collettore pari a 115 °C.
 (*) The data was obtained at a room temperature of 25 °C with 115 °C on the commutator.

(**) Flangia in acciaio 150x150x8 mm
 (***) Steel flange 150x150x8 mm

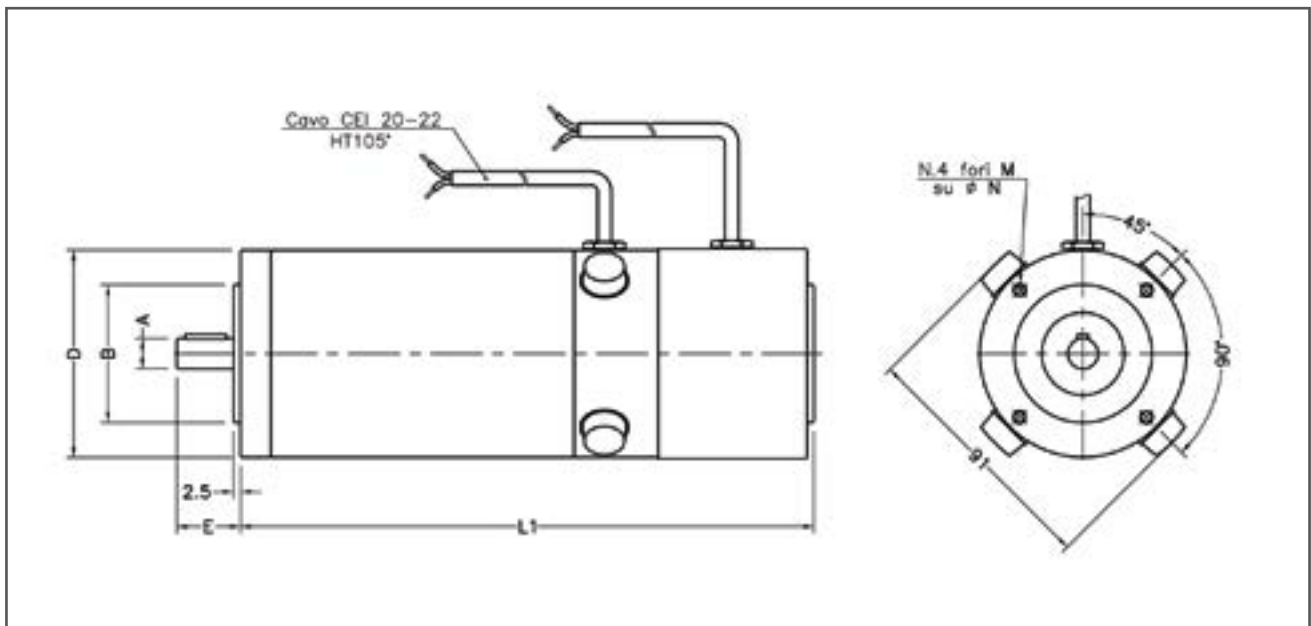
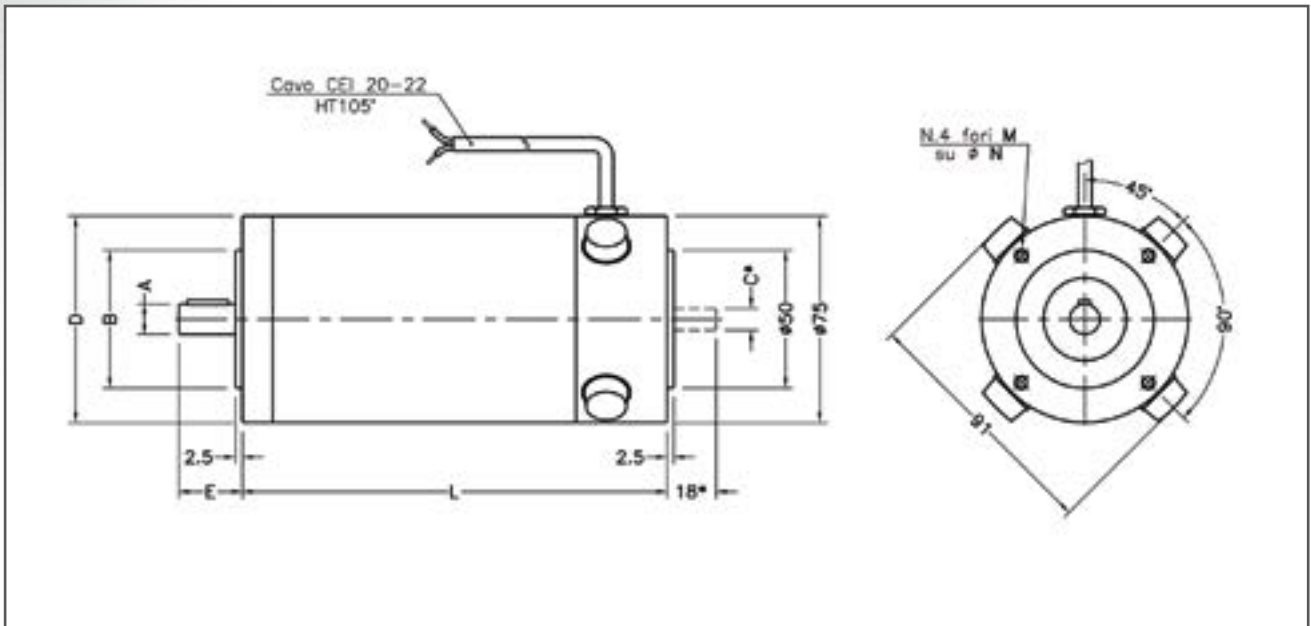

Tolleranze sulle dimensioni angolari : $\pm 5^\circ$
 The tolerance on angular dimensions: $\pm 5^\circ$

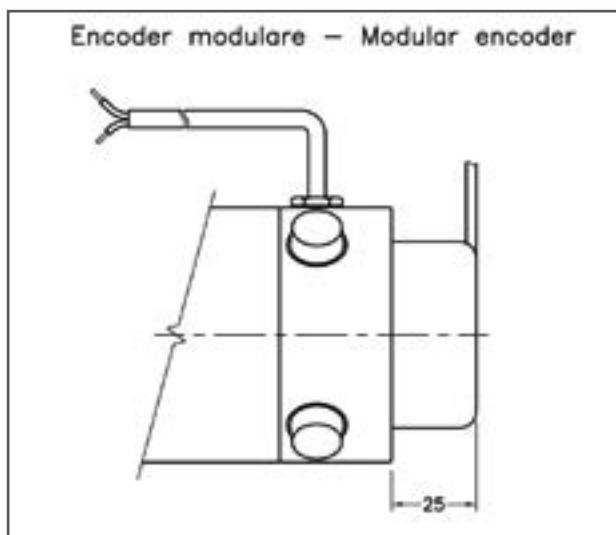

DIMENSIONI - DIMENSIONS

Taglia Size	Tipo di Flangia Flange type	A ^{h6}	B ^{h7}	C ^{h6}	D	E ^{±0,2}	L ^{±0,5}	L1 ^{±0,5}	M	N	Linguetta Key
N70C	56B14	11	50	8	75	23	114	166	M5	65	4x4x15
	63B14	14	60	8	90	30				75	5x5x20
N70M	56B14	11	50	8	75	23	154	206	M5	65	4x4x15
	63B14	14	60	8	90	30				75	5x5x20



Caratteristiche Coppia-Velocità

Torque-Speed characteristics

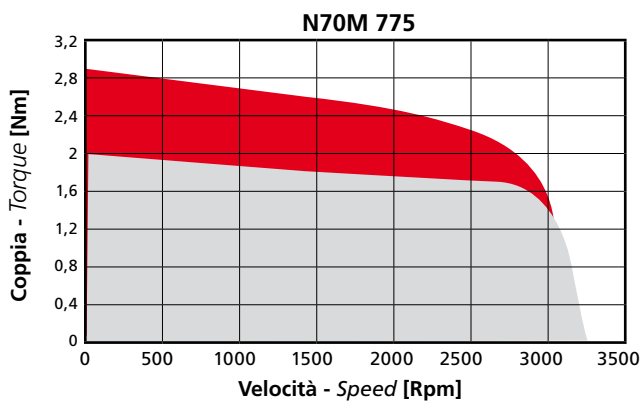
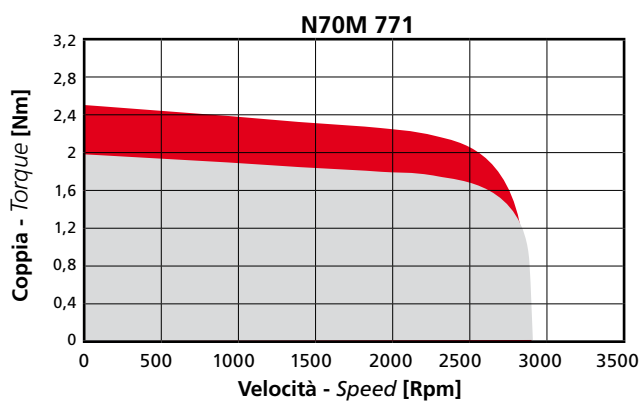
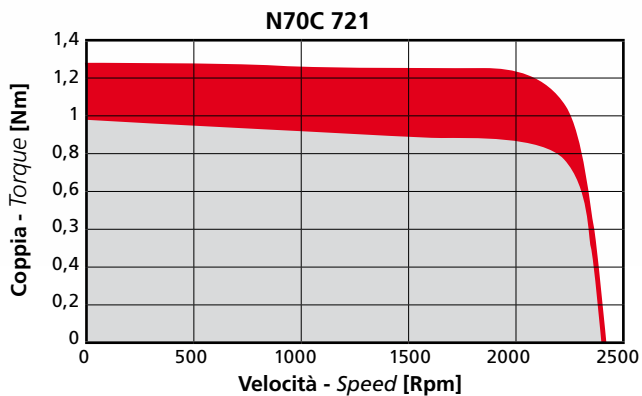
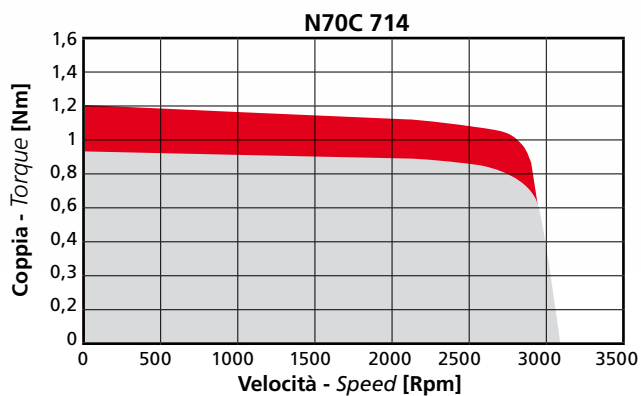
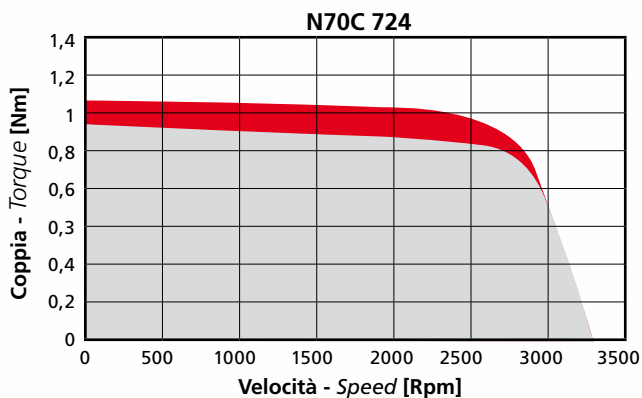
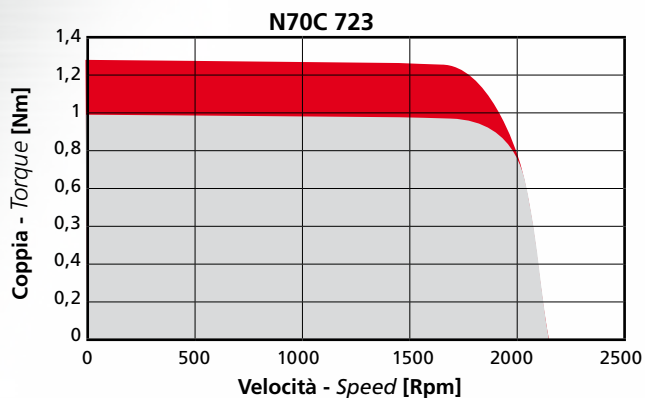

■ S1

■ S2, 30 min.

CARATTERISTICHE GENERALI - GENERAL CHARACTERISTICS

Tipo Type		N100C			N100M		
Tensione Nominale Rated Voltage	V	48	65	90	90		
Velocità Nominale Rated Speed	Rpm	3150	2900	2900	3000		
Potenza Nominale Rated Power	W	571	538	568	861		
Codice di Avvolgimento Winding Code		722	719	715	726		

CARATTERISTICHE TECNICHE - TECHNICAL CHARACTERISTICS

Coppia Continuativa di Stallo (*) Continuous Stall Current (*)	Nm	2,05	2,05	2,05	4,01		
Corrente Continuativa di Stallo (*) Continuous Stall Torque (*)	A	15,2	10,4	8,0	14,6		
Coppia Nominale (*) Rated Torque (*)	Nm	1,73	1,77	1,87	2,74		
Corrente Nominale (*) Rated Current (*)	A	13,5	9,4	7,3	10,7		
Coppia di Picco allo Spunto Start Peak Torque	Nm	6,15	6,15	6,15	12,03		
Corrente di Picco Start Peak Torque	A	45,6	31,2	24	43,8		
Resistenza Totale Total Resistance	Ω	0,37	0,50	0,72	0,36		
Induttanza Inductance	mH	0,38	0,82	1,48	0,56		
Costante di Coppia Torque Constant	Nm/A	0,135	0,197	0,256	0,275		
Costante di Tensione Voltage Constant	V/10 ³ Rpm	14,60	21,00	29	28,90		
Costante di Tempo Elettrica Electrical Time Constant	ms	1,0	1,6	2,1	1,6		
Costante di Tempo Termica Thermal Time Constant	min	32	19	20	28		

DATI MECCANICI - MECHANICAL DATA

Momento di Inerzia Moment of Inertia	Kg·m ²	8,7E-4			1,8E-3		
Massa Mass	Kg	4,5			6,5		
Massimo Carico Radiale Maximum Radial Load	N	380			450		
Massimo Carico Assiale Maximum Axial Load	N	100			100		

CARATTERISTICHE TERMICHE - THERMAL CHARACTERISTICS

Temperatura di Funzionamento Rated Temperature	°C	0 ÷ 40 °C					
Classe di Isolamento Type of Insulation		F					
Grado di Protezione Level of Protection		IP44					
Montaggio Mounting		Flangiato - Flanged (**)					

(*) Dati rilevati a temperatura ambiente di 25°C e con temperatura massima del collettore pari a 115 °C.
(*) The data was obtained at a room temperature of 25 °C with 115 °C on the commutator.

(**) Flangia in acciaio 150x150x8 mm
(**) Steel flange 150x150x8 mm

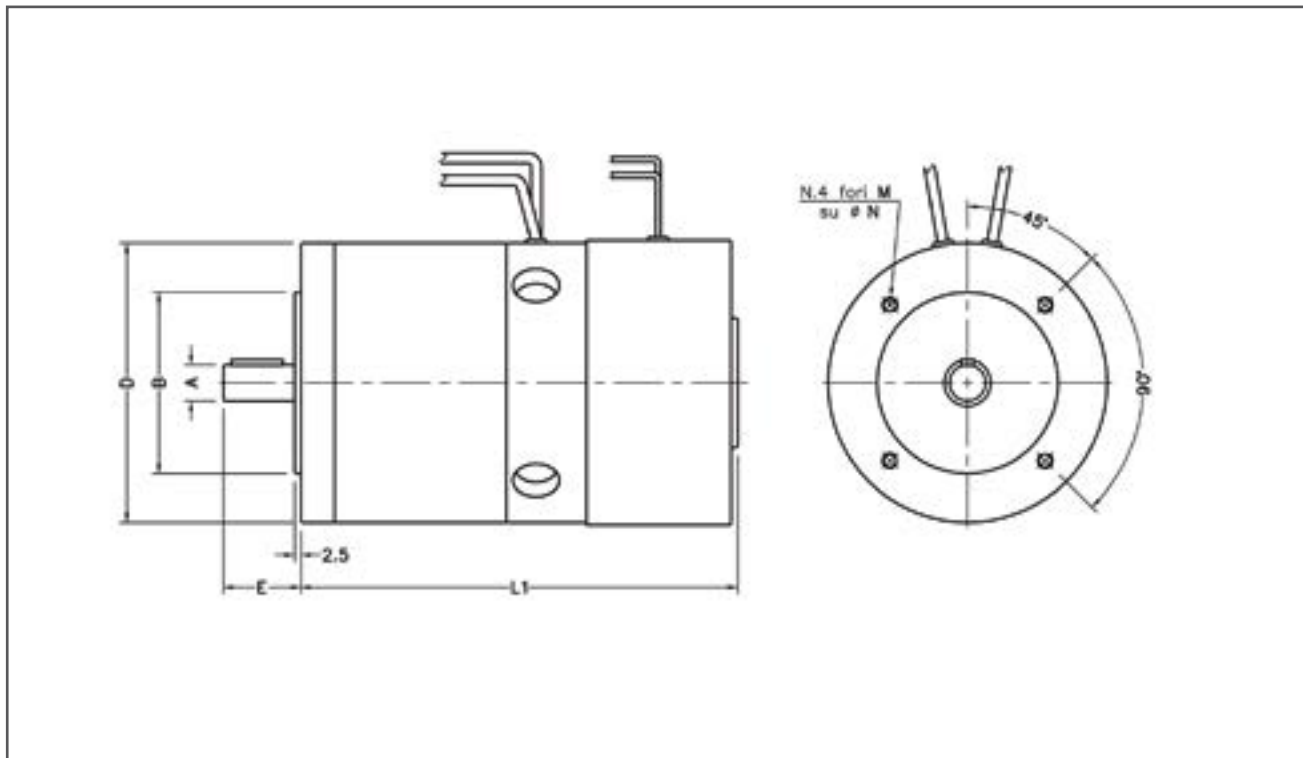
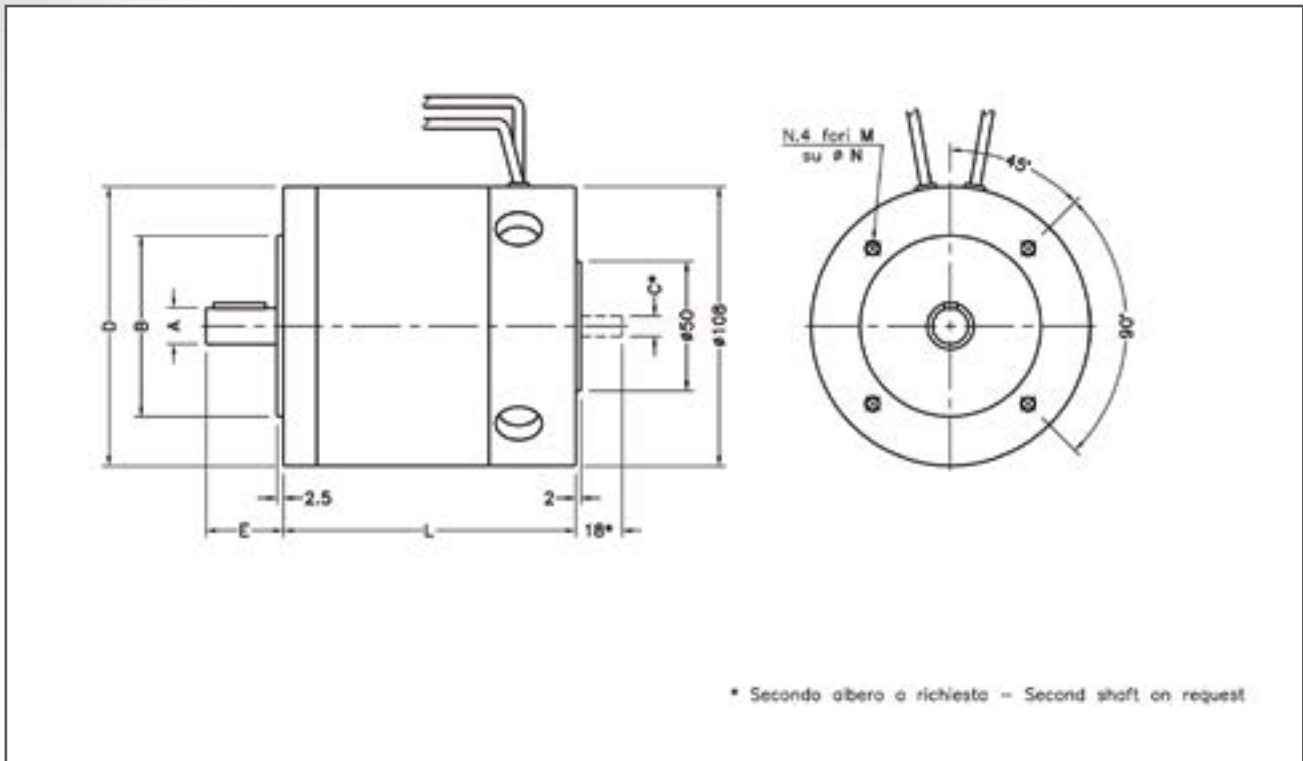

Tolleranze sulle dimensioni angolari : $\pm 5^\circ$
 The tolerance on angular dimensions: $\pm 5^\circ$

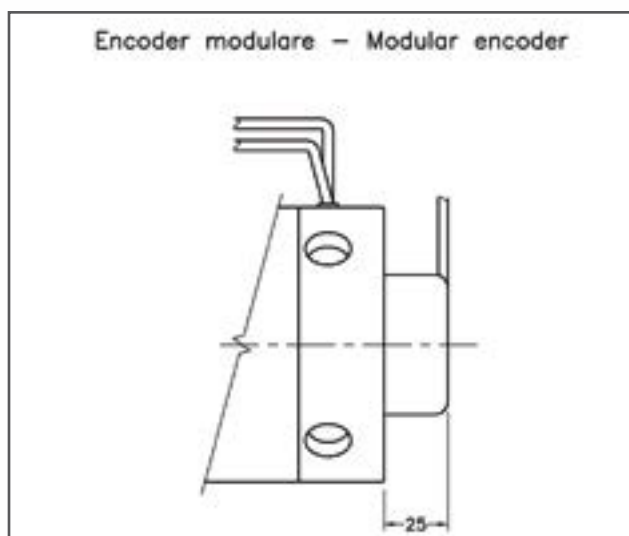

DIMENSIONI - DIMENSIONS

Taglia Size	Tipo di Flangia Flange type	A ^{b6}	B ^{b7}	C ^{b6}	D	E ^{±0.2}	L ^{±0.5}	L1 ^{±0.5}	M	N	Linguetta Key
N100C	63B14	14	60	8	108	30	116	169	M5	75	5x5x20
	71B14		70						M6	85	
	63B5		95						M8(1)	115	
	71B5		110						∅9	130	
N100M	63B14	14	60	8	108	30	149	202	M5	75	5x5x20
	71B14		70						M6	85	
	63B5		95						M8(1)	115	
	71B5		110						∅9	130	

(1) A causa di interferenza fra viti e corpo motore non è possibile praticare i fori passanti come da normativa UNEL-MEC
 (1) Threaded holes instead of through holes due to interference between the screws and the motor body

(2) Flangia di forma quadrata 120x120 mm
 (2) Square flange 120x120 mm



Caratteristiche Coppia-Velocità

Torque-Speed characteristics

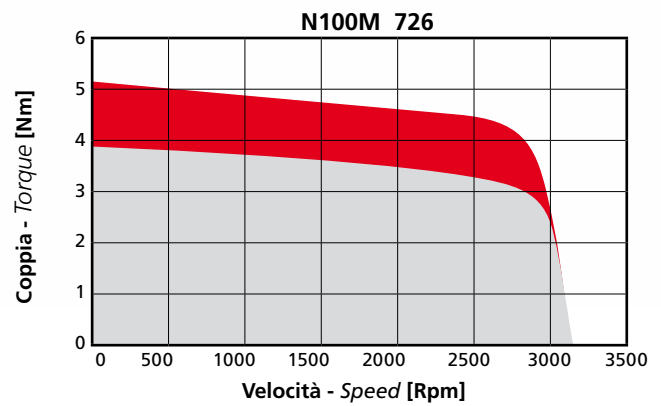
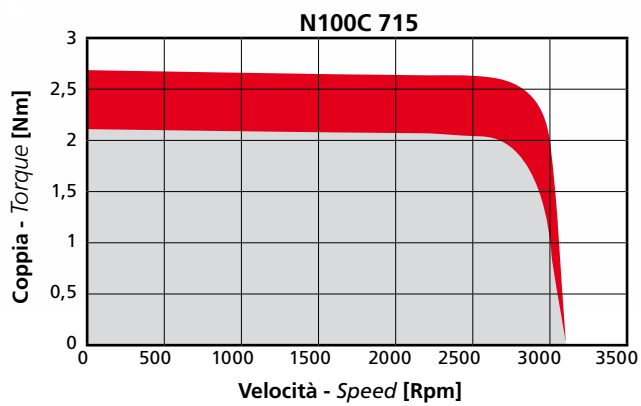
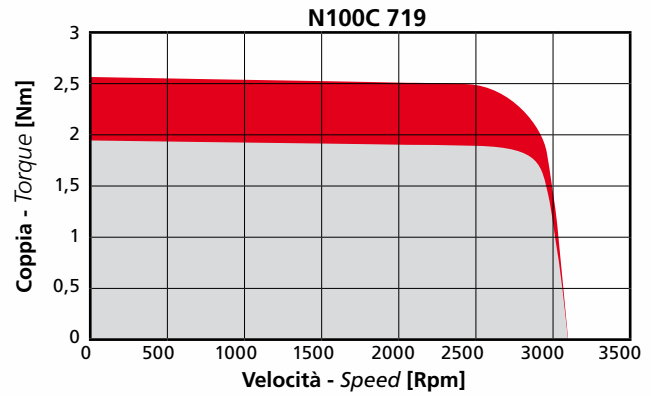
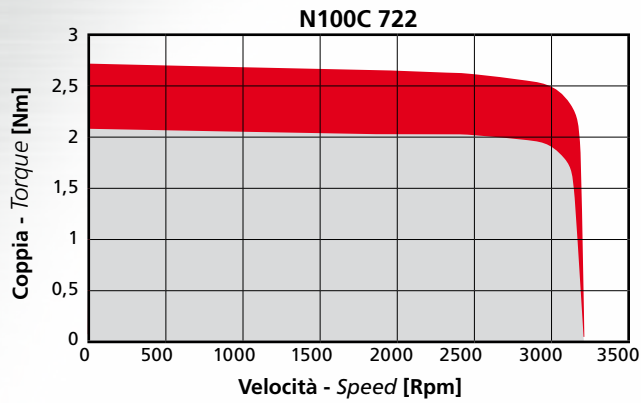

□ S1

■ S2, 30 min.

Designazione motore

Purchasing Code

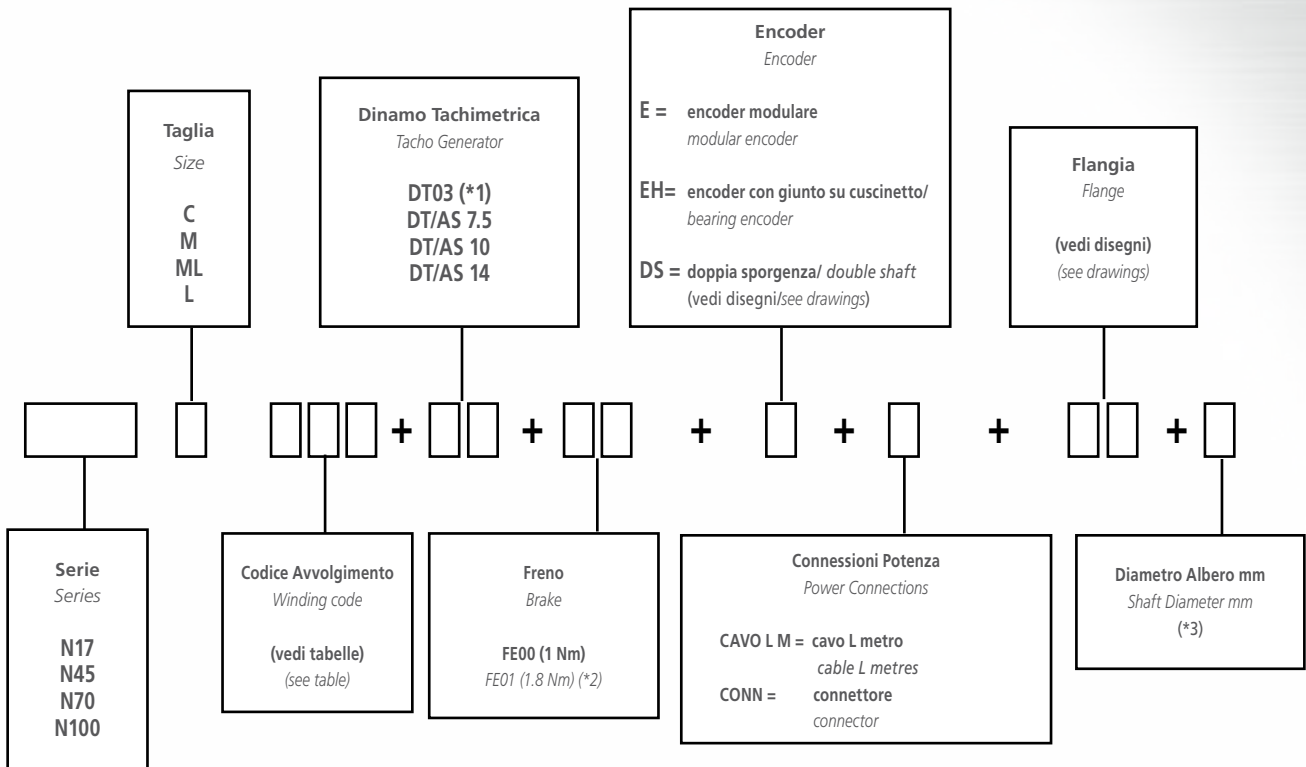

(*1) Disponibile solo per la serie N17.
Available only for N17 series.

(*2) Disponibile solo per la serie N70 e N100.
Available only for N70 and N100 series.

(*3) Nelle serie N70 e N100 è possibile avere motori con flangiature ibride (es. PAM 56B14 con albero =11 mm).
N70 and N100 are available with mixed coupling system (eg. PAM 56B14 flange with shaft = 11 mm).

Tipo Encoder Encoder Type	Conteggio Count	ppr	Canali Channels	Logica Logic	Alimentazione Power Supply
E	Incrementale Incremental	4 ÷ 1000	A,B,Z	Push Pull line driver	5 Vdc / 8 ÷ 24 Vdc
EH	Incrementale Incremental	4 ÷ 2000	A,B,Z	Push Pull line driver	

Esempio di designazione

N70C721 DT10 + FE00 + E + CONN + 56B14 + 11

Questa designazione definisce un motore con le seguenti caratteristiche:

- Serie N70
- Taglia C
- Codice di avvolgimento 721 (vedi tabelle)
- Dinamo tachimetrica 10 V/1000 rpm
- Freno con coppia nominale di 1 Nm
- Encoder modulare
- Connettore di potenza
- Flangia 56B14
- Diametro dell'albero 11 mm

Purchasing example

N70C721 + DT10 + FE00 + E + CONN + 56B14 + 11

This code represents the following motor:

- Series N70
- Size C
- Winding code 721 (see table)
- Tacho generator 10 V/1000 rpm
- Brake with rated torque 1 Nm
- Modular encoder
- Power connector
- Flange type 56B14
- Shaft diameter 11 mm





Traction





INFORMAZIONI GENERALI

GENERAL INFORMATION

Siboni srl produce una vasta gamma di prodotti tra cui una serie di motori cc a magneti permanenti dedicati alla trazione elettrica. Questa serie è stata concepita e realizzata ponendo particolare cura nella fase di progettazione, massimizzando tutte le caratteristiche elettroniche.

Tutto ciò, unitamente all'utilizzo di materiali di prim'ordine e alle lavorazioni meccaniche eseguite con tolleranze centesimali, ci ha permesso di porre al vertice della sua fascia di mercato questa gamma di motori che vantano

- Elevato rendimento
- Elevata coppia di accelerazione
- Elevata linearità di coppia

Queste caratteristiche, unitamente ad un elevato rapporto inerziale, rendono perfetti questi motori per l'equipaggiamento di veicoli elettrici ottimizzando al massimo le prestazioni e l'autonomia di funzionamento.

Ciò non preclude però il loro impiego in altri campi di applicazione: dall'azionamento di pompe di ogni genere fino all'impiego come servomotore.

A tale scopo sono state implementate diverse flangiature, fra le più comuni sul mercato, con forma costruttiva B5 o B14, permettendo un accoppiamento rapido e preciso.

Tutti i motori sono in versione standard IP44, isolamento in classe F e sono costituiti e collaudati in conformità alle normative IEC.

Siboni srl produces a wide range of products amongst which there is a series of dc permanent magnet electric motors dedicated to electric traction.

This series has been realised with particular emphasis being placed on its development.

Employing the best quality materials and taking the utmost care in the mechanical machining makes these motors leaders in their category.

Their principal qualities are:

- High efficiency*
- High starting torque*
- High torque linearity*

These motors have a high inertial ratio and are the best solution for electric traction as they maximise the performance and endurance of electric vehicles.

They can also be used in other applications, e.g. pumps, or as servomotors.

A wide range of flanges are available, B5 and B14 design, enabling them to be coupled with all kinds of reducers and many other applications.

All the motors are IP44 in their standard version, with class F rated insulation and are manufactured and tested in conformity with IEC standards.

Serie 75 PXF

75 PXF Series

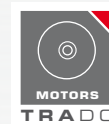

CARATTERISTICHE GENERALI - GENERAL CHARACTERISTICS

Tipo Type	75PXF						
Tensione Nominale Rated Voltage	V	12	12	12	24	24	24
Velocità Nominale Rated Speed	Rpm	2200	2800	3000	1800	2150	3000
Potenza Nominale Rated Power	W	265	323	314	226	259	346
Codice di Avvolgimento Winding Code		829	842	859	892	079	810

DATI ELETTRICI - ELECTRICAL DATA

Coppia Nominale (*) Rated Torque (*)	Nm	1,15	1,10	1,00	1,2	1,15	1,1
Corrente Nominale Rated Current	A	26,7	32,9	34,5	13,0	13,7	18,0
Coppia di Picco allo Spunto (*) Start Peak Torque (*)	Nm	3,5	3,3	3,0	3,6	3,5	3,3
Corrente di Picco Start Peak Current	A	80,1	98,7	103,5	39,0	41,1	54,0
Resistenza Totale Total Resistance	Ω	0,08	0,04	0,03	0,35	0,27	0,19
Induttanza Inductance	mH	0,16	0,08	0,07	0,58	0,43	0,26
Costante di Coppia Torque Constant	Nm/A	0,043	0,033	0,029	0,092	0,084	0,061
Costante di Tensione Voltage Constant	V/K Rpm	4,90	4,00	3,60	10,5	8,90	6,90
Costante di Tempo Elettrica Electrical Time Constant	ms	2,00	2,00	2,33	1,66	1,59	1,37

DATI MECCANICI - MECHANICAL DATA

Momento di Inerzia Moment of Inertia	Kg.m ²	1,90E-04					
Massa Mass	Kg	3,8					
Massimo Carico Radiale Maximum Radial Load	N	350					
Massimo Carico Assiale Maximum Axial Load	N	100					

CARATTERISTICHE TERMICHE - THERMAL CHARACTERISTICS

Temperatura di Funzionamento Rated Temperature	°C	0 ÷ 40					
Classe di Isolamento Type of Insulation		F					
Grado di Protezione Level of Protection		IP44					
Montaggio Mounting		In Aria / Free Still Air					

(*) Dati rilevati a temperatura ambiente di 25°C e con temperatura massima del collettore pari a 115 °C.

(*) The data was obtained at a room temperature of 25 °C with 115 °C on the commutator.

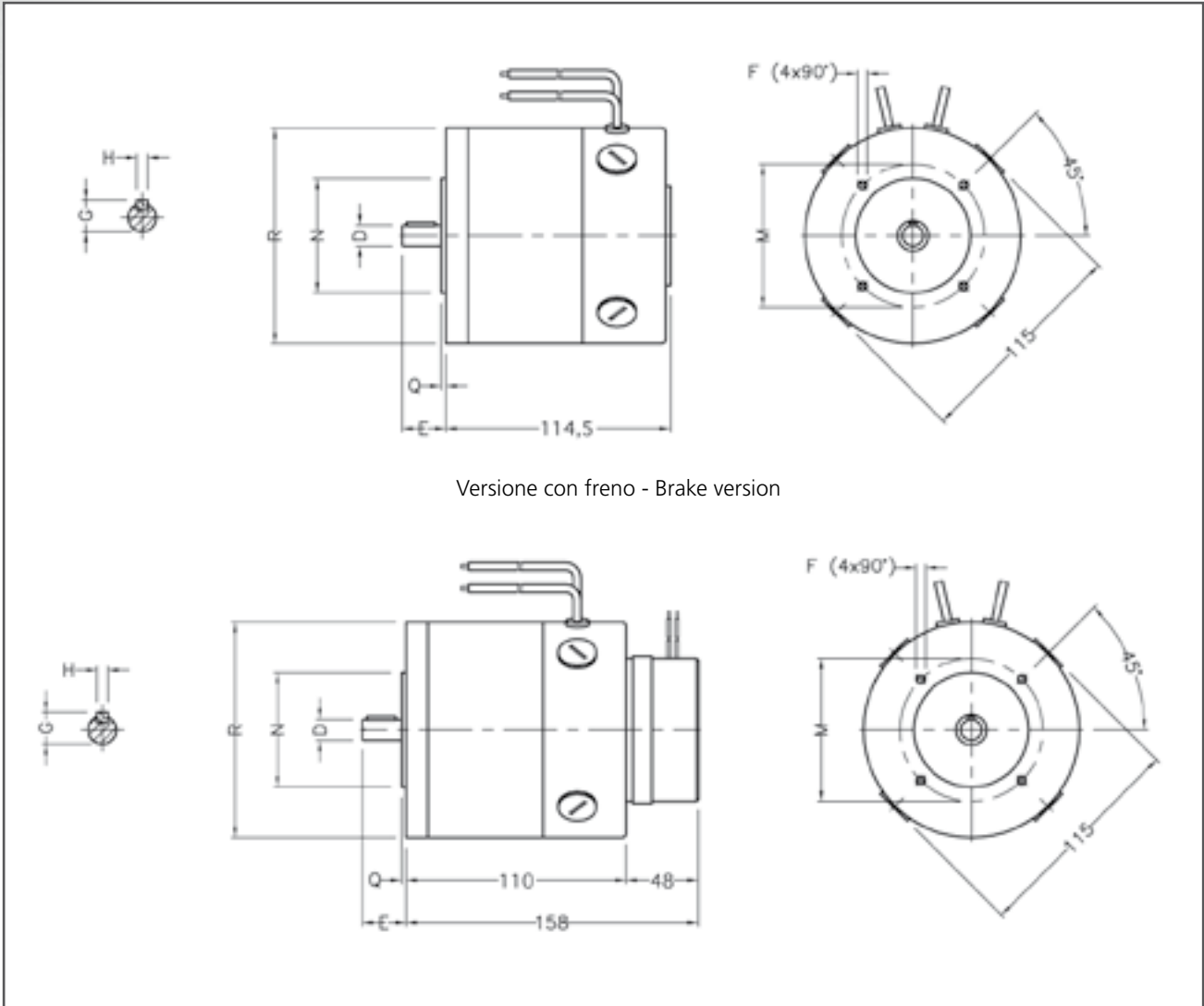

Versione con freno - Brake version

DIMENSIONI - DIMENSIONS

VERSIONE / Type		D _{H6}	E	F	G	H	M	N _{H7}	Q	R
B14	PAM56	9	20	M5	10.2	3	65	50	2.5	113
	PAM63	11	23	M5	12.5	4	75	60	2.5	113
	PAM71	14	30	M6	16	5	85	70	2.5	113

Caratteristiche coppia-velocità

Torque-speed characteristics

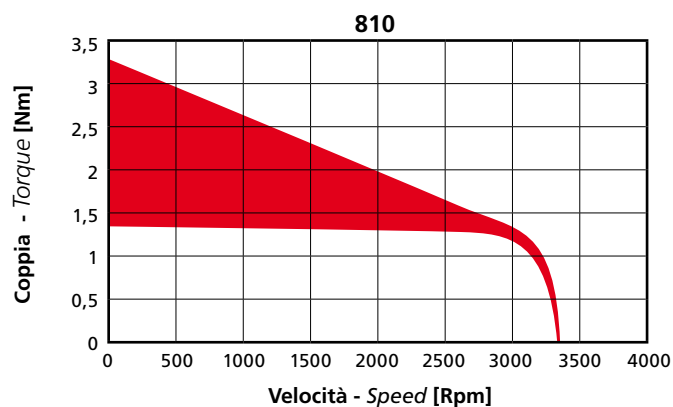
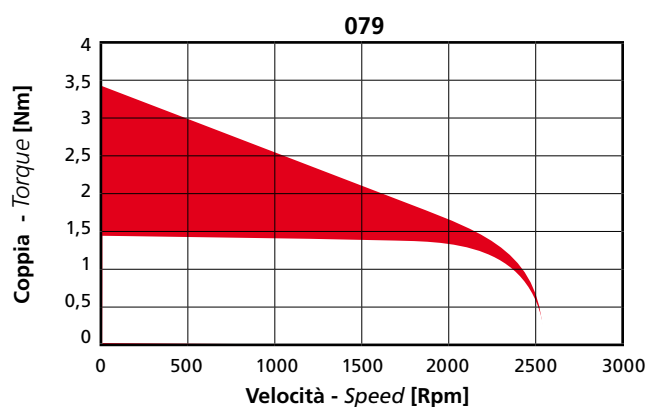
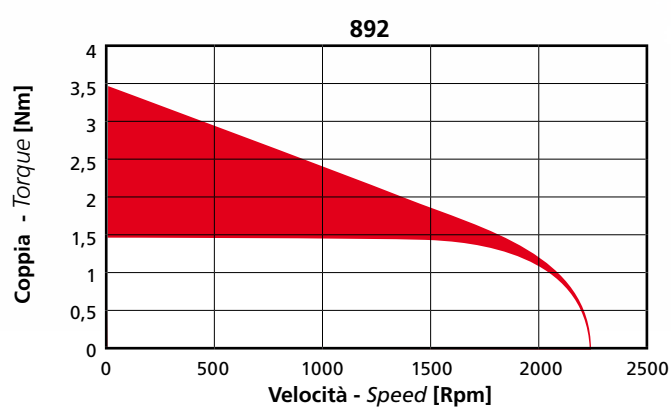
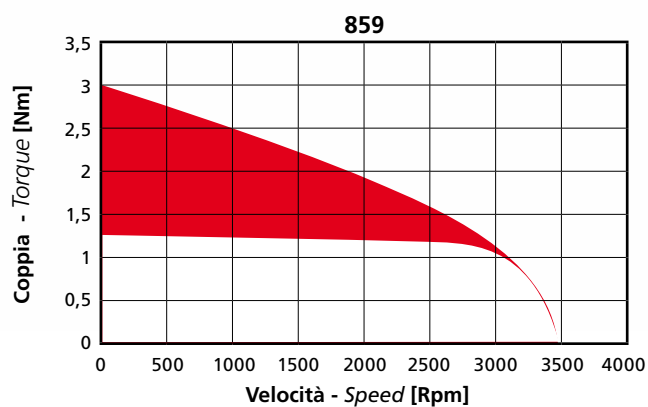
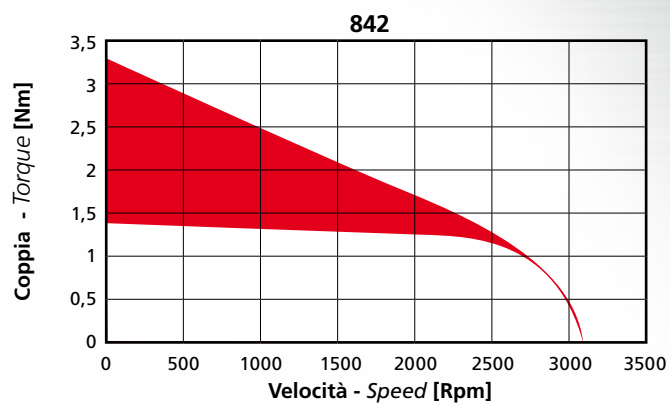
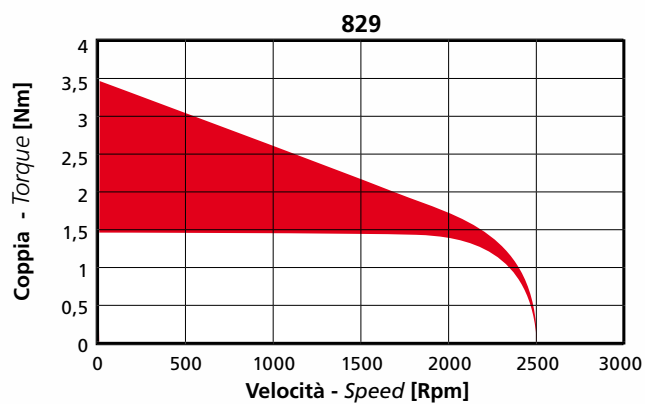
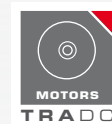

■ S2 -30'

■ S3



Serie 75 PF

75 PF Series

CARATTERISTICHE GENERALI - GENERAL CHARACTERISTICS

Tipo Type	75PF									
Tensione Nominale Rated Voltage	V	12	12	12	12	24	24	24	24	24
Velocità Nominale Rated Speed	Rpm	1100	1500	2100	2600	800	1600	1950	3000	4000
Potenza Nominale Rated Power	W	242	330	374	436	184	335	408	565	628
Codice di Avvolgimento Winding Code		979	992	967	997	070	056	978	048	047

DATI ELETTRICI - ELECTRICAL DATA

Coppia Nominale (*) Rated Torque (*)	Nm	2,10	2,10	1,70	1,60	2,20	2,00	2,00	1,80	1,50
Corrente Nominale Rated Current	A	29	35	37	45	13	18	22	27	28
Coppia di Picco allo Spunto (*) Start Peak Torque (*)	Nm	6,3	6,3	5,1	4,8	6,6	6	6	5,4	4,5
Corrente di Picco Start Peak Current	A	87	105	111	135	39	54	66	81	84
Resistenza Totale Total Resistance	Ω	0,15	0,09	0,07	0,06	0,46	0,22	0,18	0,10	0,08
Induttanza Inductance	mH	0,17	0,10	0,08	0,04	0,97	0,40	0,28	0,12	0,09
Costante di Coppia Torque Constant	Nm/A	0,07	0,06	0,05	0,04	0,17	0,11	0,09	0,07	0,05
Costante di Tensione Voltage Constant	V/K Rpm	8,6	6,5	5,0	4,4	19,2	12,6	10,7	7,1	5,6
Costante di Tempo Elettrica Electrical Time Constant	ms	0,85	0,65	0,58	0,67	2,11	1,82	1,56	1,33	1,38

DATI MECCANICI - MECHANICAL DATA

Momento di Inerzia Moment of Inertia	Kg-m ²	2,10E-04								
Massa Mass	Kg	5,3								
Massimo Carico Radiale Maximum Radial Load	N	380								
Massimo Carico Assiale Maximum Axial Load	N	110								

CARATTERISTICHE TERMICHE - THERMAL CHARACTERISTICS

Temperatura di Funzionamento Rated Temperature	°C	0 ÷ 40								
Classe di Isolamento Type of Insulation		F								
Grado di Protezione Level of Protection		IP44								
Montaggio Mounting		In Aria / Free Still Air								

(*) Dati rilevati a temperatura ambiente di 25°C e con temperatura massima del collettore pari a 115 °C.
 (*) The data was obtained at a room temperature of 25 °C with 115 °C on the commutator.

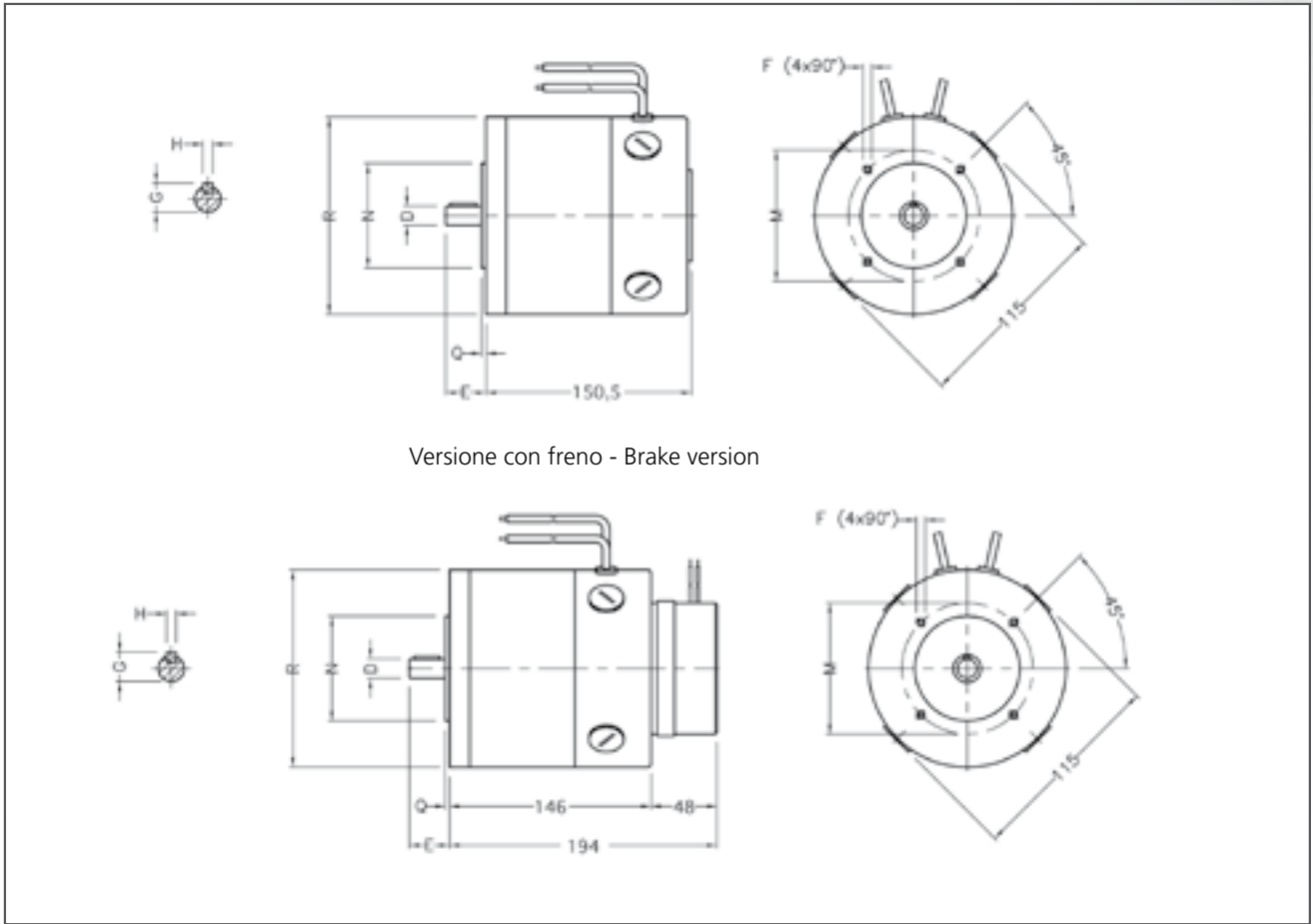

DIMENSIONI - DIMENSIONS

VERSIONE / Type		D _{H6}	E	F	G	H	M	N _{H7}	Q	R
B14	PAM63	11	23	M5	12.5	4	75	60	2.5	113
	PAM71	14	30	M6	16	5	85	70	2.5	113

Caratteristiche coppia-velocità

Torque-speed characteristics

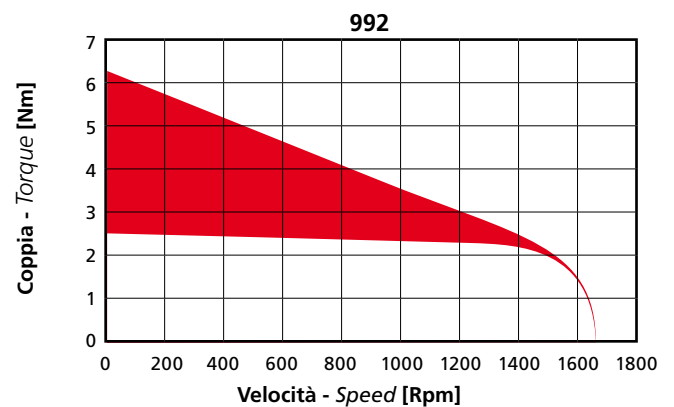
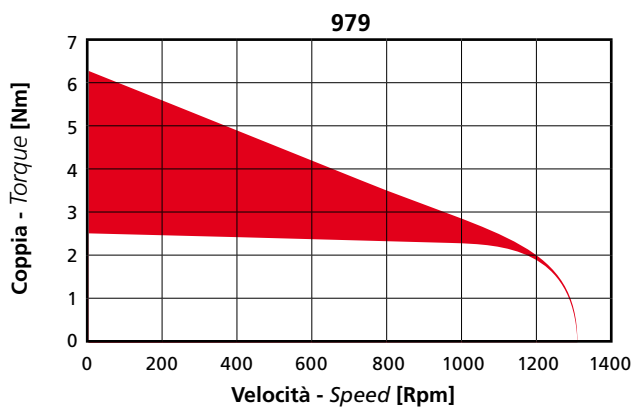

Caratteristiche coppia-velocità

Torque-speed characteristics

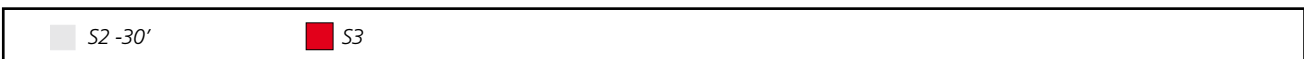
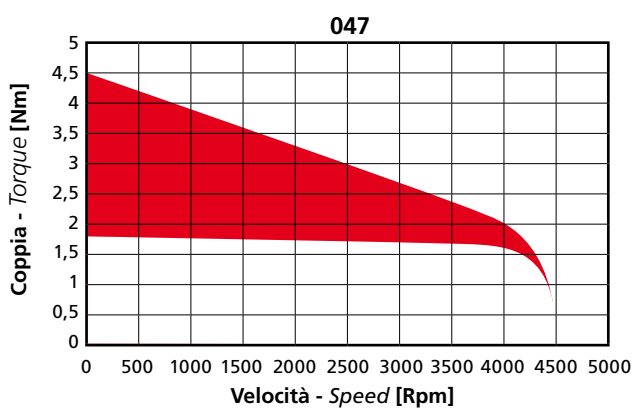
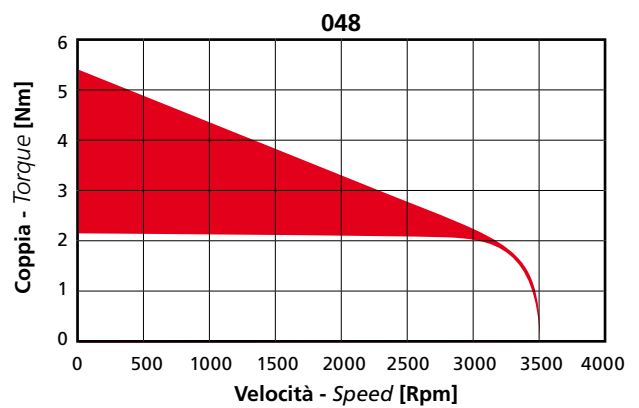
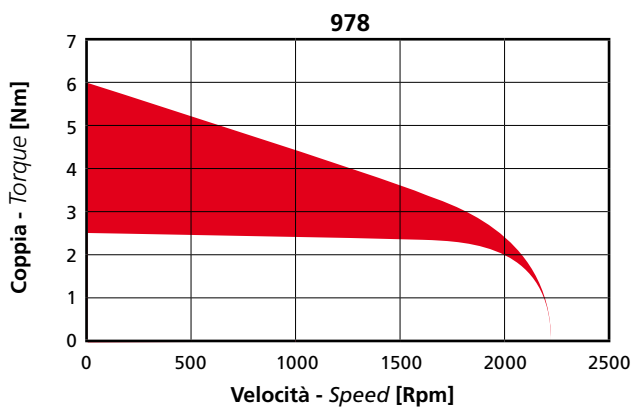
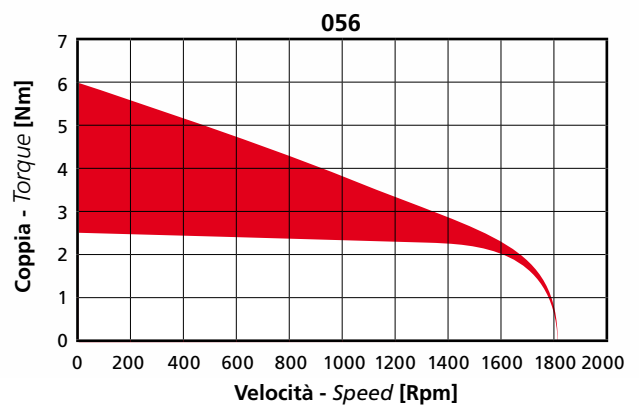
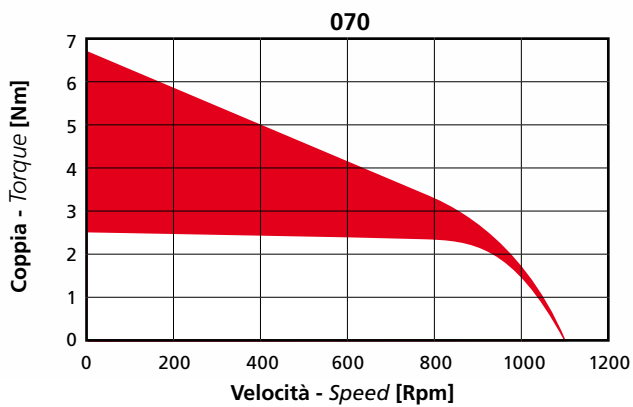
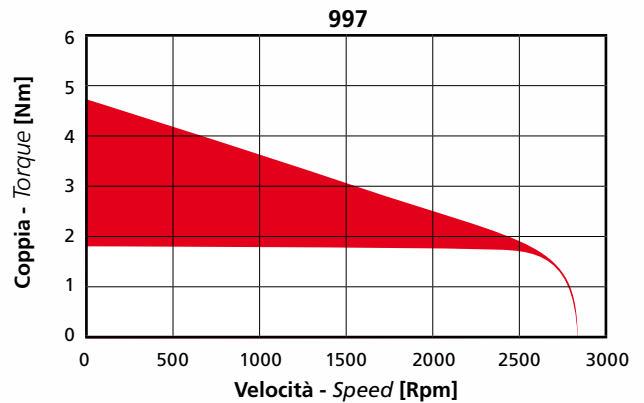
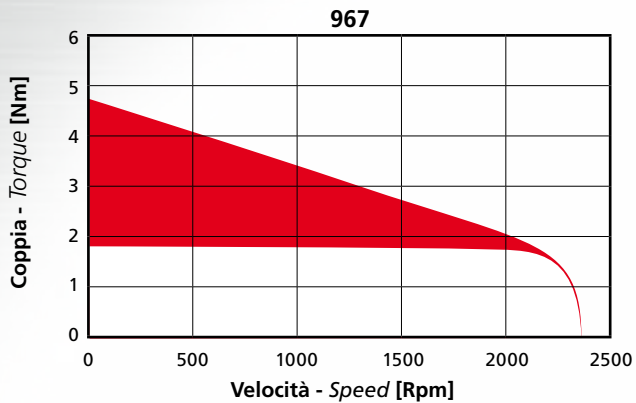

Serie 75 PS

75 PS Series

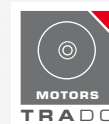

CARATTERISTICHE GENERALI - GENERAL CHARACTERISTICS

Tipo Type	75PS					
Tensione Nominale Rated Voltage	V	12	12	24	24	24
Velocità Nominale Rated Speed	Rpm	1400	2000	1450	1800	2800
Potenza Nominale Rated Power	W	390	500	420	480	700
Codice di Avvolgimento Winding Code		974	937	994	802	806

DATI ELETTRICI - ELECTRICAL DATA

Coppia Nominale (*) Rated Torque (*)	Nm	2,60	2,40	2,80	2,50	2,40
Corrente Nominale Rated Current	A	40	50	21	25	36
Coppia di Picco allo Spunto (*) Start Peak Torque (*)	Nm	7,8	7,2	8,4	7,5	7,2
Corrente di Picco Start Peak Current	A	120	150	63	75	108
Resistenza Totale Total Resistance	Ω	0,10	0,08	0,19	0,17	0,13
Induttanza Inductance	mH	0,12	0,06	0,36	0,28	0,14
Costante di Coppia Torque Constant	Nm/A	0,07	0,05	0,13	0,10	0,07
Costante di Tensione Voltage Constant	V/K Rpm	7,3	5,7	14,1	11,4	8,0
Costante di Tempo Elettrica Electrical Time Constant	ms	1,20	0,75	1,89	1,65	1,08

DATI MECCANICI - MECHANICAL DATA

Momento di Inerzia Moment of Inertia	Kg.m ²	2,60E-04				
Massa Mass	Kg	6,2				
Massimo Carico Radiale Maximum Radial Load	N	380				
Massimo Carico Assiale Maximum Axial Load	N	110				

CARATTERISTICHE TERMICHE - THERMAL CHARACTERISTICS

Temperatura di Funzionamento Rated Temperature	$^{\circ}\text{C}$	0 ÷ 40				
Classe di Isolamento Type of Insulation		F				
Grado di Protezione Level of Protection		IP44				
Montaggio Mounting		In Aria / Free Still Air				

(*) Dati rilevati a temperatura ambiente di 25°C e con temperatura massima del collettore pari a 115 °C.

(*) The data was obtained at a room temperature of 25 °C with 115 °C on the commutator.

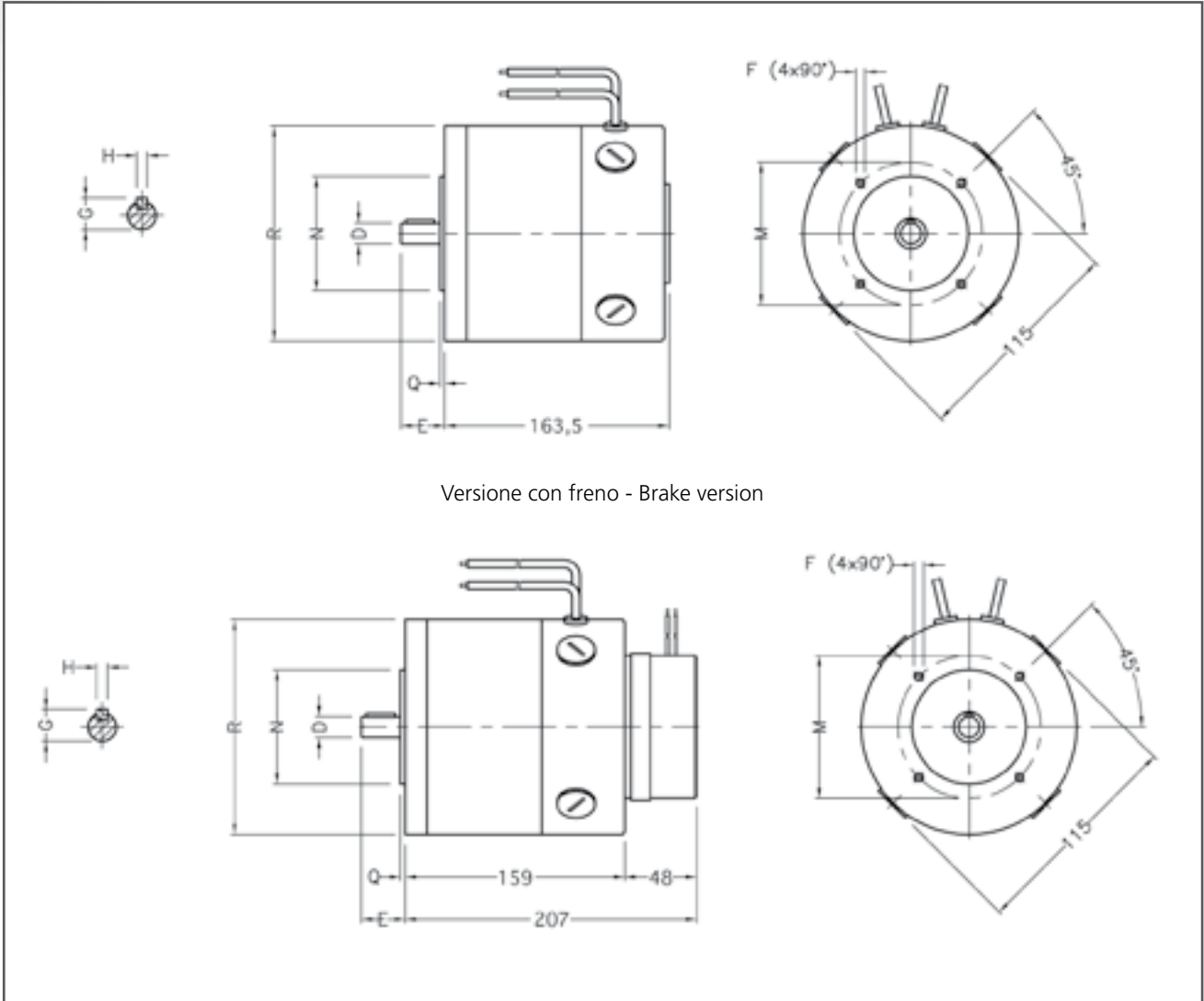

DIMENSIONI - DIMENSIONS

VERSIONE / Type		D _{H6}	E	F	G	H	M	N _{H7}	Q	R
B14	PAM63	11	23	M5	12.5	4	75	60	2.5	113
	PAM71	14	30	M6	16	5	85	70	2.5	113

Caratteristiche coppia-velocità

Torque-speed characteristics

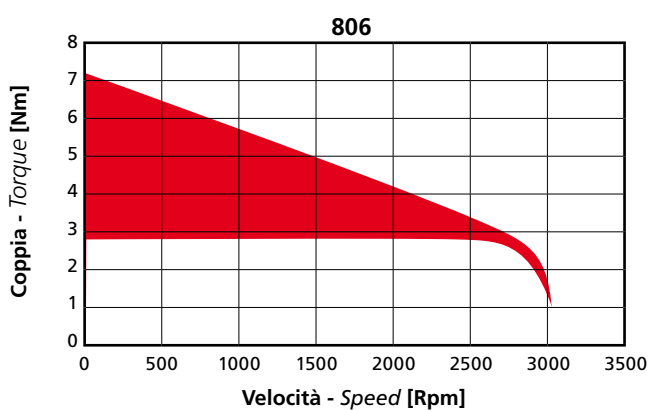
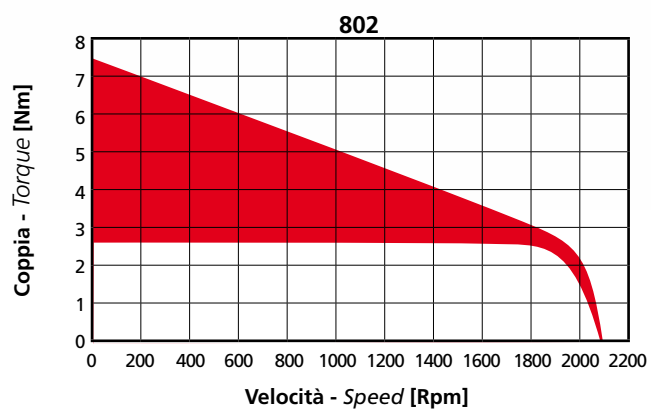
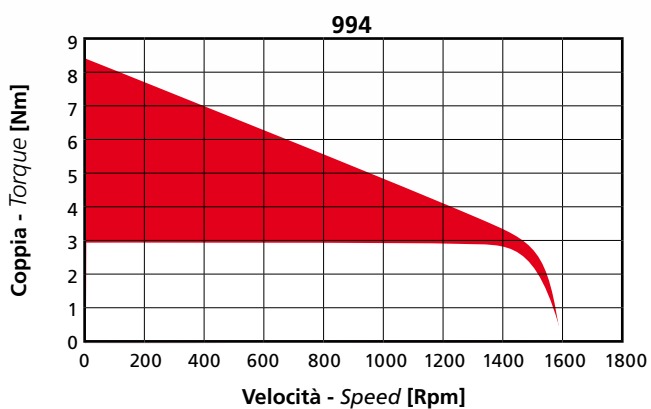
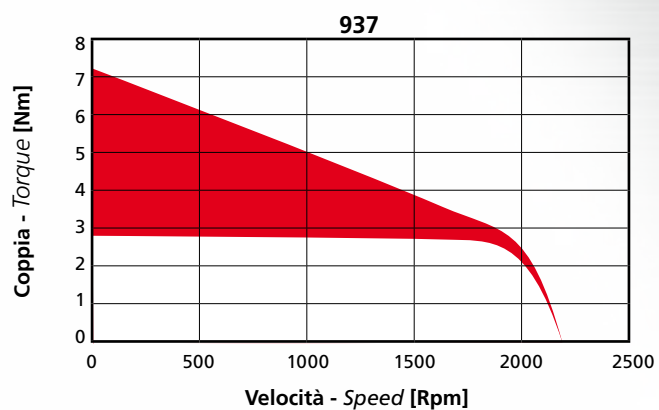
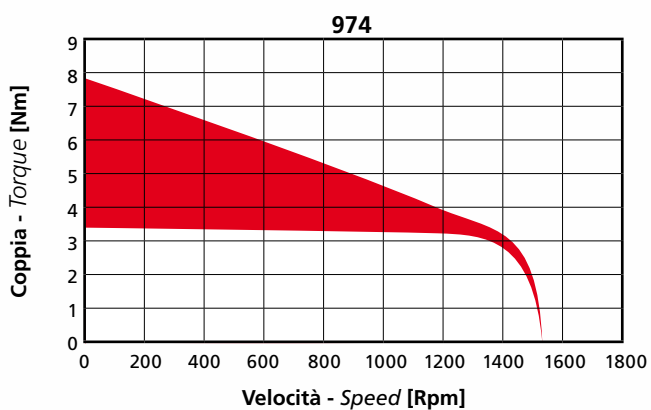

■ S2 -30'

■ S3



Serie 75 PK

75 PK Series

CARATTERISTICHE GENERALI - GENERAL CHARACTERISTICS

Tipo Type	75PK					
Tensione Nominale Rated Voltage	V	12	12	12	24	24
Velocità Nominale Rated Speed	Rpm	1300	1800	2600	1700	2800
Potenza Nominale Rated Power	W	290	418	572	463	674
Codice di Avvolgimento Winding Code		080	050	809	020	989

DATI ELETTRICI - ELECTRICAL DATA

Coppia Nominale (*) Rated Torque (*)	Nm	2,2	2,2	2,1	2,6	2,3
Corrente Nominale Rated Current	A	31,0	47,0	60,0	23,0	33,0
Coppia di Picco allo Spunto (*) Start Peak Torque (*)	Nm	6,6	6,3	6,3	7,8	6,9
Corrente di Picco Start Peak Current	A	93	141	180	69	99
Resistenza Totale Total Resistance	Ω	0,08	0,04	0,03	0,15	0,07
Induttanza Inductance	mH	0,17	0,08	0,04	0,37	0,16
Costante di Coppia Torque Constant	Nm/A	0,07	0,04	0,04	0,11	0,07
Costante di Tensione Voltage Constant	V/K Rpm	8,57	4,00	4,29	12,00	7,87
Costante di Tempo Elettrica Electrical Time Constant	ms	2,27	2,00	1,40	2,45	2,29

DATI MECCANICI - MECHANICAL DATA

Momento di Inerzia Moment of Inertia	Kg-m ²	2,70E-04				
Massa Mass	Kg	6,8				
Massimo Carico Radiale Maximum Radial Load	N	380				
Massimo Carico Assiale Maximum Axial Load	N	110				

CARATTERISTICHE TERMICHE - THERMAL CHARACTERISTICS

Temperatura di Funzionamento Rated Temperature	°C	0 ÷ 40				
Classe di Isolamento Type of Insulation		F				
Grado di Protezione Level of Protection		IP44				
Montaggio Mounting		In Aria / Free Still Air				

(*) Dati rilevati a temperatura ambiente di 25°C e con temperatura massima del collettore pari a 115 °C.

(*) The data was obtained at a room temperature of 25 °C with 115 °C on the commutator.

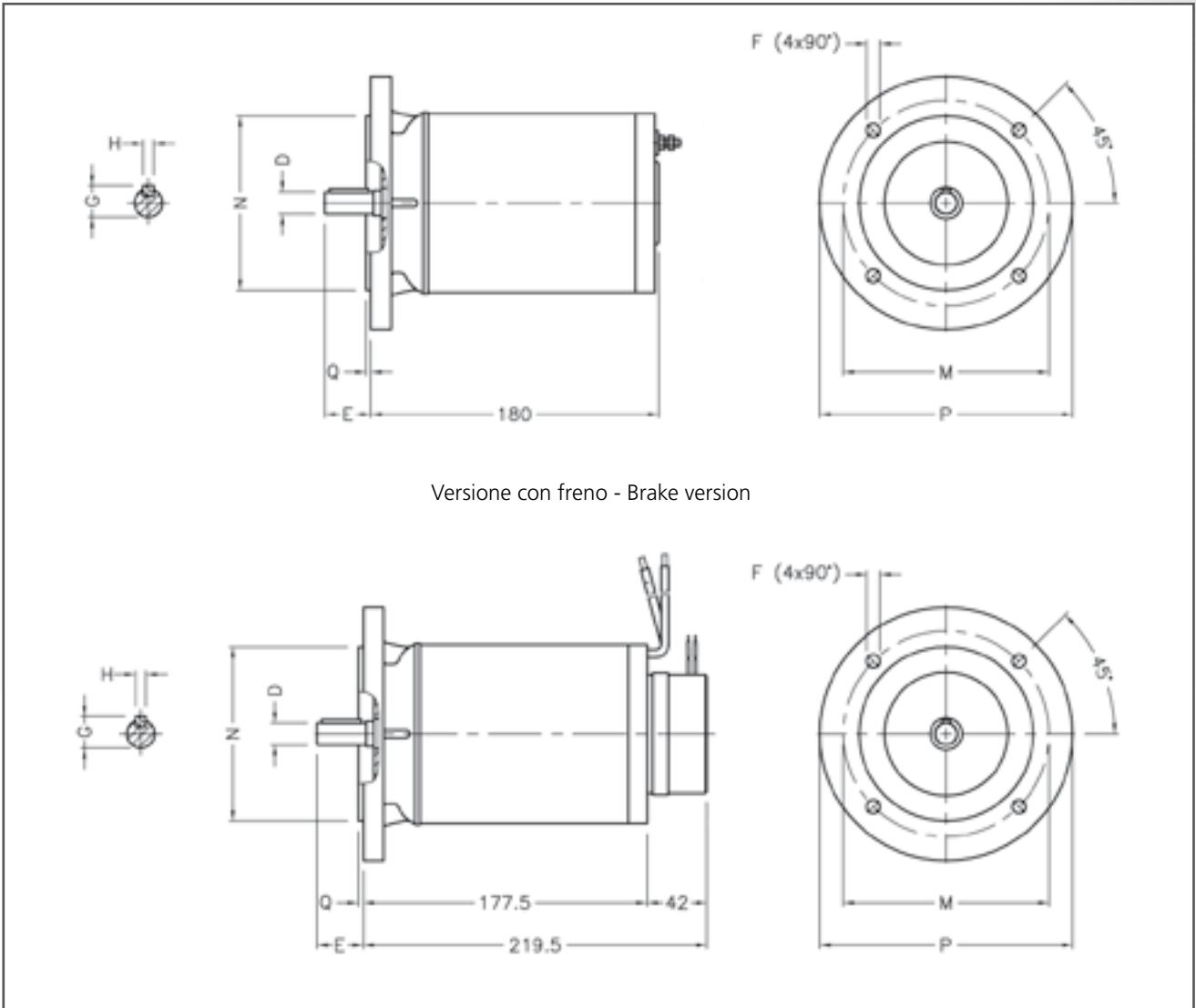

DIMENSIONI - DIMENSIONS

VERSIONE / Type		D _{H6}	E	F	G	H	M	N _{H7}	P	Q
B5	PAM63	11	23	9	12.5	4	115	95	140	3
	PAM71	14	30	9	16	5	130	110	160	3



Caratteristiche coppia-velocità

Torque-speed characteristics

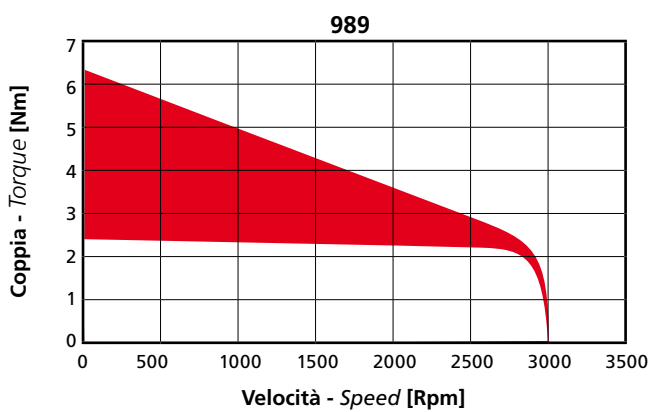
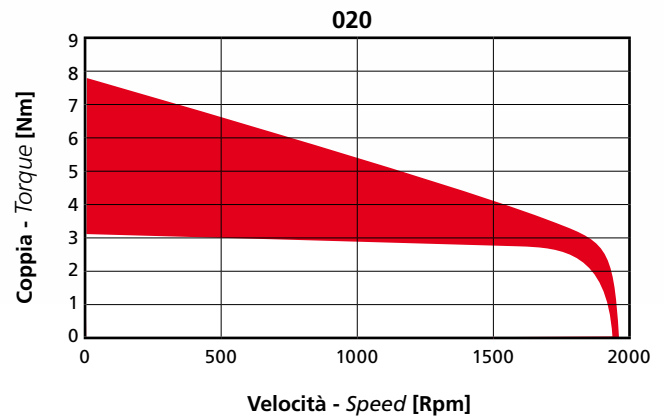
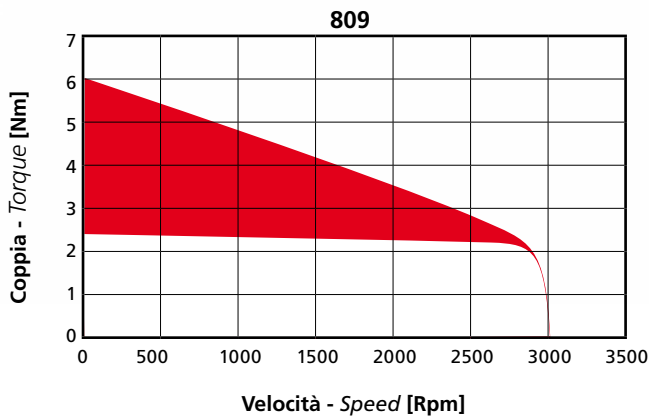
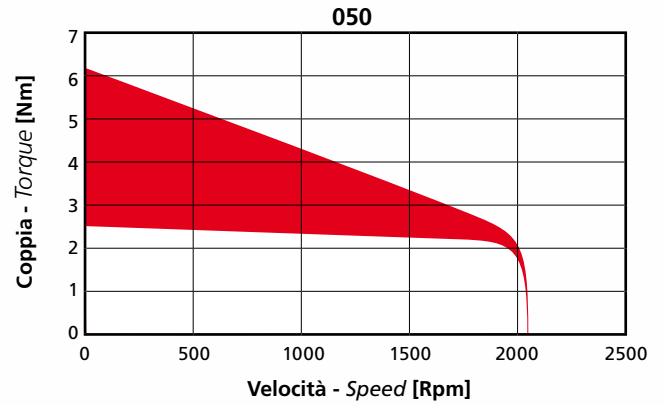
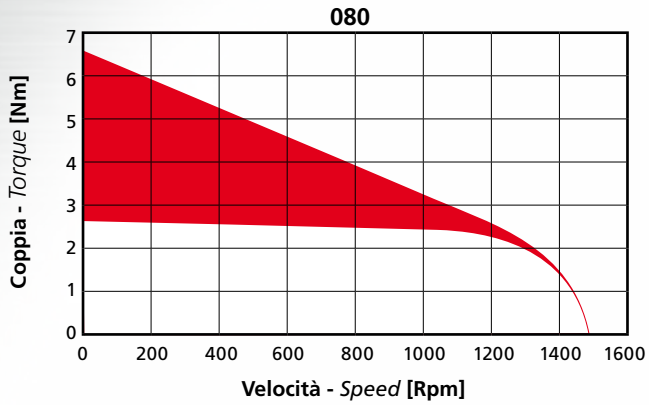

■ S2 -30'

■ S3

Serie 75 PX

75 PX Series



CARATTERISTICHE GENERALI - GENERAL CHARACTERISTICS

Tipo Type	75 PX					
Tensione Nominale Rated Voltage	V	12	24	24	24	24
Velocità Nominale Rated Speed	Rpm	1400	1600	2050	2450	2700
Potenza Nominale Rated Power	W	530	620	780	870	1000
Codice di Avvolgimento Winding Code		995	987	053	983	985

DATI ELETTRICI - ELECTRICAL DATA

Coppia Nominale (*) Rated Torque (*)	Nm	3,6	3,7	3,6	3,5	3,4
Corrente Nominale Rated Current	A	55	31	37	43	48
Coppia di Picco allo Spunto (*) Start Peak Torque (*)	Nm	10,8	11,1	10,9	10,5	10,2
Corrente di Picco Start Peak Current	A	165	93	111	129	144
Resistenza Totale Total Resistance	Ω	0,05	0,23	0,13	0,11	0,06
Induttanza Inductance	mH	0,07	0,12	0,10	0,08	0,07
Costante di Coppia Torque Constant	Nm/A	0,07	0,12	0,10	0,08	0,07
Costante di Tensione Voltage Constant	V/K Rpm	7,06	12,63	10,00	8,90	8,28
Costante di Tempo Elettrica Electrical Time Constant	ms	1,40	0,94	1,22	1,18	1,64

DATI MECCANICI - Mechanical Data

Momento di Inerzia Moment of Inertia	Kg·m ²	3,70 E-04				
Massa Mass	Kg	8,1				
Massimo Carico Radiale Maximum Radial Load	N	380				
Massimo Carico Assiale Maximum Axial Load	N	110				

CARATTERISTICHE TERMICHE - Thermal Characteristics

Temperatura di Funzionamento Rated Temperature	°C	0 ÷ 40				
Classe di Isolamento Type of Insulation		F				
Grado di Protezione Level of Protection		IP44				
Montaggio Mounting		In Aria / Free Still Air				

(*) Dati rilevati a temperatura ambiente di 25°C e con temperatura massima del collettore pari a 115 °C.

(*) The data was obtained at a room temperature of 25 °C with 115 °C on the commutator.

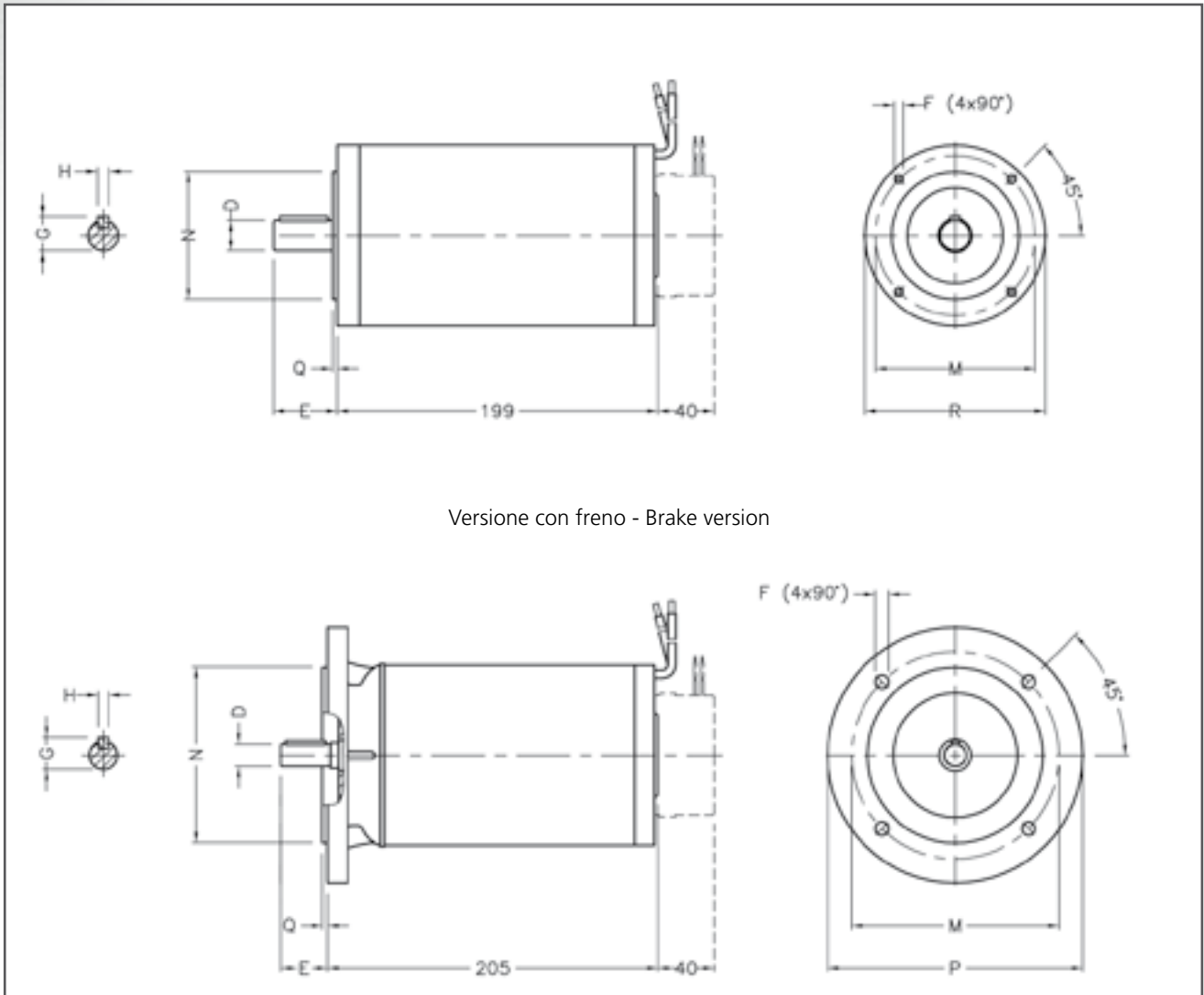

DIMENSIONI - DIMENSIONS

VERSIONE / Type		D _{H6}	E	F	G	H	M	N _{H7}	P	Q	R
B14	PAM71	14	30	M6	16	5	85	70	-	2.5	114
	PAM80	19	40	M6	21.5	6	100	80	-	3	114
B5	PAM71	14	30	9	16	5	130	110	160	3	-

Caratteristiche coppia-velocità

Torque-speed characteristics

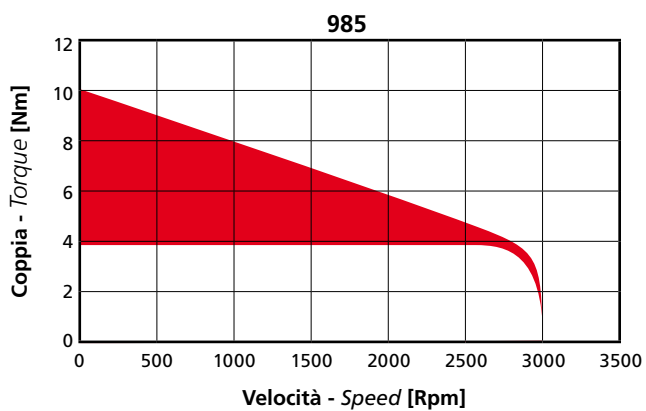
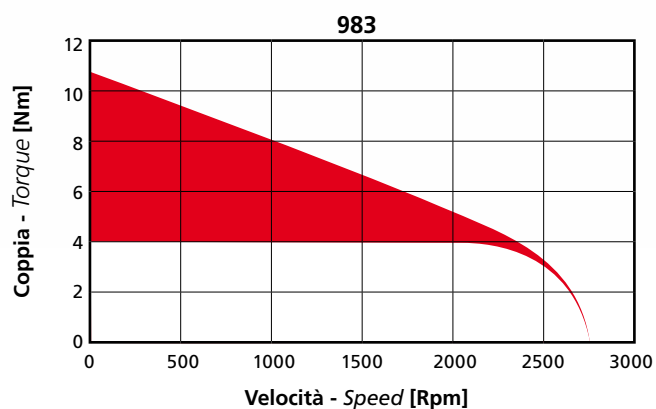
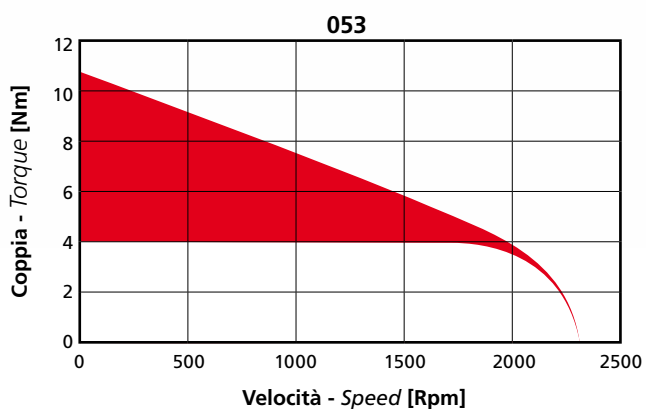
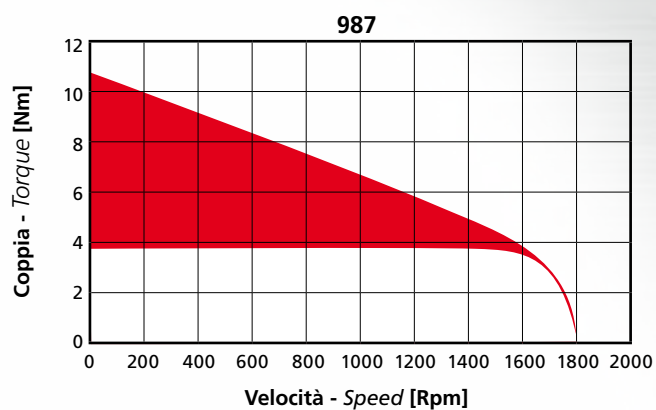
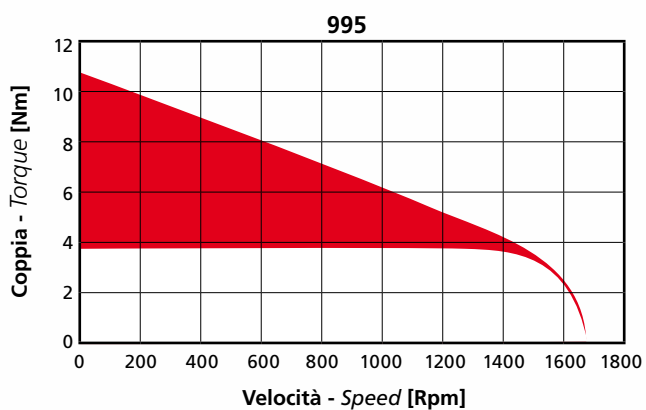



Serie 75 PQ

75 PQ Series

CARATTERISTICHE GENERALI - GENERAL CHARACTERISTICS

Tipo Type	75 PQ				
Tensione Nominale Rated Voltage	V	12	24	24	24
Velocità Nominale Rated Speed	Rpm	1500	1500	2000	3300
Potenza Nominale Rated Power	W	800	930	1150	1350
Codice di Avvolgimento Winding Code		643	641	653	674

DATI ELETTRICI - ELECTRICAL DATA

Coppia Nominale (*) Rated Torque (*)	Nm	5,2	6	5,6	4
Corrente Nominale Rated Current	A	83	50	60	65
Coppia di Picco allo Spunto (*) Start Peak Torque (*)	Nm	15,6	18,0	16,8	12,0
Corrente di Picco Start Peak Torque	A	249	150	180	195
Resistenza Totale Total Resistance	Ω	0,035	0,082	0,055	0,04
Induttanza Inductance	mH	0,05	0,2	0,1	0,06
Costante di Coppia Torque Constant	Nm/A	0,06	0,12	0,09	0,06
Costante di Tensione Voltage Constant	V/K Rpm	6,6	13,3	11,4	7,4
Costante di Tempo Elettrica Electrical Time Constant	ms	1,43	2,44	1,82	1,50

DATI MECCANICI - MECHANICAL DATA

Momento di Inerzia Moment of Inertia	Kg·m ²	3,70 E-04			
Massa Mass	Kg	13,2			
Massimo Carico Radiale Maximum Radial Load	N	400			
Massimo Carico Assiale Maximum Axial Load	N	130			

CARATTERISTICHE TERMICHE - THERMAL CHARACTERISTICS

Temperatura di Funzionamento Rated Temperature	°C	0 ÷ 40			
Classe di Isolamento Type of Insulation		F			
Grado di Protezione Level of Protection		IP44			
Montaggio Mounting		In Aria / Free Still Air			

(*) Dati rilevati a temperatura ambiente di 25°C e con temperatura massima del collettore pari a 115 °C.

(*) The data was obtained at a room temperature of 25 °C with 115 °C on the commutator.

Versione B14 - B14 version

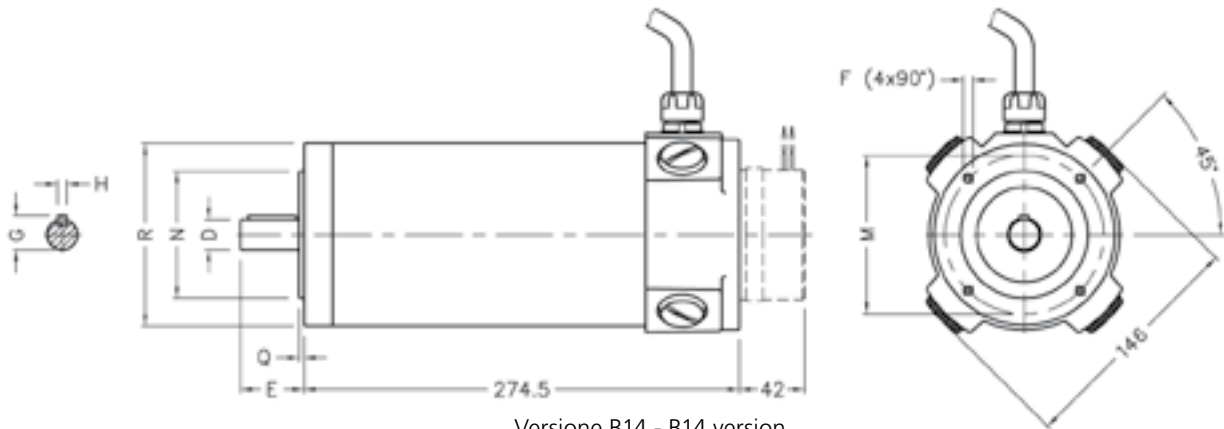

Versione B14 - B14 version

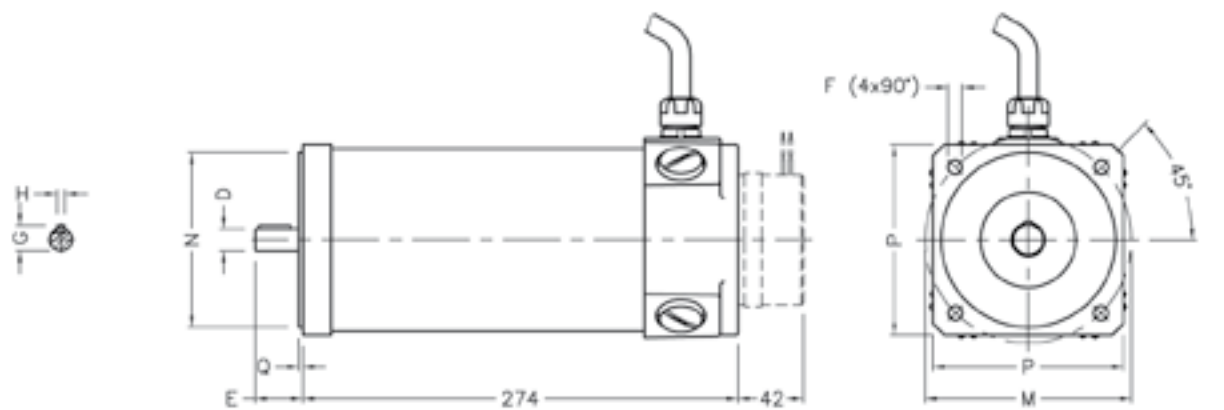

Versione ventilata VQ - Ventilated version VQ
Disponibile sia in B14 che B5 - Available in B14 and B5

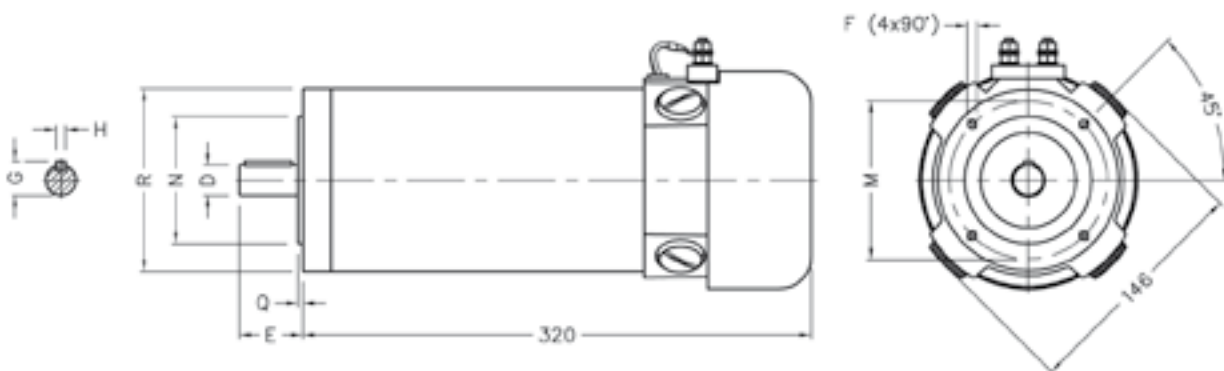

DIMENSIONI - DIMENSIONS

VERSIONE / Type	DH6	E	F	G	H	M	NH7	P	Q	R	
B14	PAM71	14	30	M6	16	5	85	70	-	2.5	114
	PAM80	19	40	M6	21.5	6	100	80	-	3	120
B5	PAM71	14	30	9	16	5	130	110	120	3	-
	PAM80	19	40	11.5	21.5	6	165	130	140	3	-
	PAM90	24	50	11.5	27	8	165	130	140	3	-

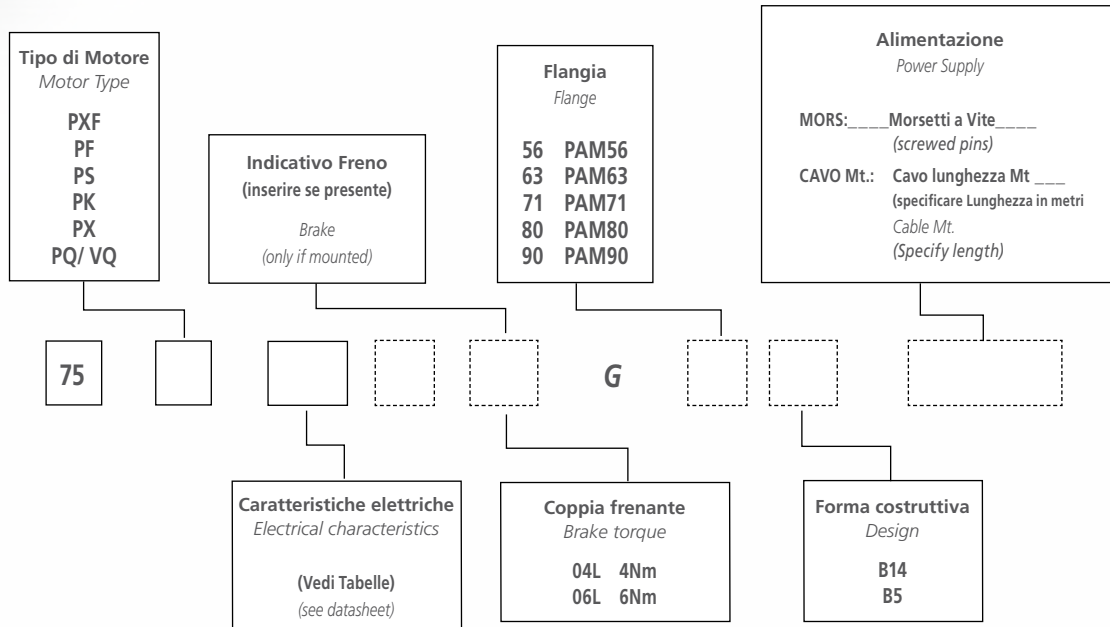

Esempio di designazione

75 PX 937 G80 B14 MORS

Questa designazione definisce un motore con le seguenti caratteristiche:

- Albero \varnothing 14 mm
- Grandezza PX
- Codice avvolgimento elettrico 937
- Flange PAM80
- Flangiature in forma B14
- Alimentazione tramite morsetti a vite

Sono disponibili esecuzioni personalizzate, per le quali contattare la nostra rete vendita.

Purchasing example

75 PX 937 G80 B14 MORS

This code represents the following motor:

- shaft diameter 14 mm
- PX size
- Winding code 937
- Flange PAM 80
- B14 Design
- Power supply by screwed pins

Contact our commercial office for non-standard versions



Siboni S.r.l. si riserva tutti i diritti di proprietà intellettuale del presente documento. È vietata la copia e la diffusione anche parziale, senza previa autorizzazione scritta.

Siboni S.r.l. si riserva il diritto di apportare modifiche senza preavviso.
Sostituisce tutte le versioni precedenti con revisione inferiore.

Siboni S.r.l. reserves the rights to the intellectual property of this document. The disclosure and copying of it, even in part, is expressly forbidden without prior written consent.

*Siboni S.r.l. reserves the right to modify the products without prior notice.
This version replaces all previous versions with a lower revision.*

MOTORS

ITA - ENG

11 - 2018



SIBONI
MOTORS AND SOLUTIONS

www.siboni.it