

Double Rockers

**AD-P /
AD-PV**
for flange
fixation

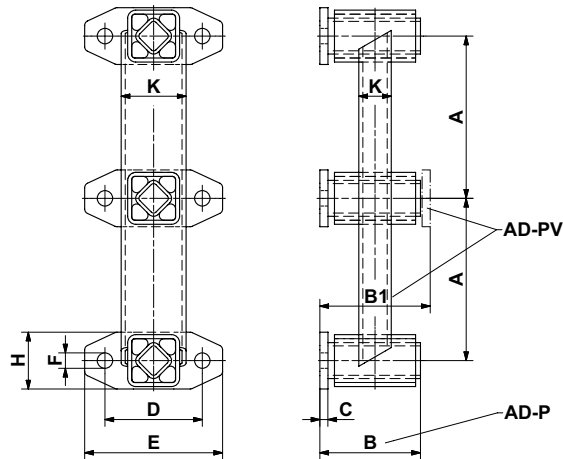

Type AD-PV with inverted flange

Art. No.	Type	G [N]		c _d [N/mm]	A	B	B1	C	D	E	øF	H	K	Weight [kg]	Material structure
		K=2	K=3												
07 111 001	AD-P 18	150	120	23	100	62	-	5	60	85	9.5	35	40 x 20	1.2	Steel welded constructions, ROSTA blue painted
07 121 001	AD-PV 18					-	68								
07 111 002	AD-P 27	300	240	31	120	73	-	5	80	110	11.5	45	55 x 34	2.6	
07 121 002	AD-PV 27					-	80								
07 111 003	AD-P 38	600	500	45	160	95	-	6	100	140	14	60	70 x 50	5.0	
07 121 003	AD-PV 38					-	104								
07 111 004	AD-P 45	1'200	1'000	50	200	120	-	8	130	180	18	70	80 x 40	8.5	
07 121 004	AD-PV 45					-	132								
07 111 005	AD-P 50	1'800	1'500	56	250	145	-	10	140	190	18	80	90 x 50	12.9	
07 121 005	AD-PV 50					-	160								

AD-C
for frictional
center connection

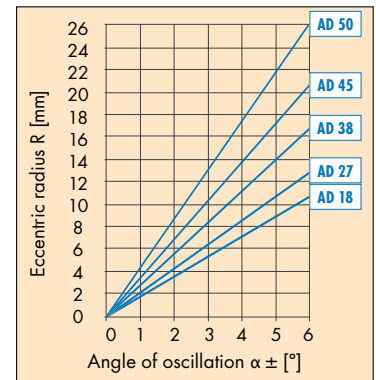
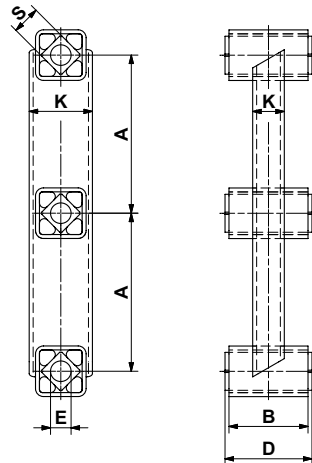

Art. No.	Type	G [N]		c _d [N/mm]	A	B	D _{-0.3} ⁰	øE	K	□S	Weight [kg]	Material structure	
		K=2	K=3									Inner square	Housing
07 101 001	AD-C 18	150	120	23	100	50	55	13 _{-0.2} ⁰	40x20	18	0.8	Light metal profile	Steel welded construction, ROSTA blue painted
07 101 002	AD-C 27	300	240	31	120	60	65	16 _{+0.3} ^{+0.5}	55x34	27	1.8		
07 101 003	AD-C 38	600	500	45	160	80	90	20 _{+0.2} ^{+0.5}	70x50	38	4.1		
07 101 004	AD-C 45	1'200	1'000	50	200	100	110	24 _{+0.2} ^{+0.5}	80x40	45	6.1		

G = max. load in N per rocker, by different K consult chapter 5 on page 2.24.

c_d = dynamic spring value by oscillation angles $\alpha \pm 5^\circ$ in speed range of $n_s = 300-600 \text{ min}^{-1}$

Further basic information and calculations on pages 2.22-2.24.

Selection table for guided systems (crank driven)

				
		One mass shaker "brute-force" system	One mass shaker "natural frequency" system	Two mass shaker "fast-runner" system with reaction force-compensation
	AU Page 2.25	Single Rocker with adjustable length. Models with right-hand and left-hand threads. 7 sizes up to 5'000 N per rocker suspension.		
	AS-P AS-C Page 2.26	Single Rocker with decided center distance. 6 sizes up to 2'500 N for flange fixation. 6 sizes up to 2'500 N for central fixation.		
	AD-P AD-C Page 2.27			Double Rocker with decided center distance. 5 sizes up to 2'500 N for flange fixation. 4 sizes up to 1'600 N for central fixation.
	AR Page 2.28	Single rocker and double rocker with adjustable length, connection of the AR elements using round pipe. Two mass shakers with design feasibility of two-directional conveying. 2 sizes up to 800 N per rocker suspension.		
	ST Page 2.29	Drive Head for crank drive transmission in shaker conveyors. Models with right-hand and left-hand threads. 9 sizes up to 27'000 N per drive head.		
	DO-A Page 2.30	Spring Accumulator with high dynamic spring value for feeder systems running close to resonance frequency. A spring accumulator consists of 2 DO-A elements. 5 sizes up to dynamic spring value of 320 N/mm.		

Notes regarding some special shaker systems:

- For free oscillating systems on pages 2.16–2.19
- For guided systems on pages 2.31 – 2.33
- For gyratory sifters on page 2.34



Technology of crank shaft driven shaker conveyors

Introduction

Oscillating shaker conveyors with crank shaft drive are widely used for the transportation and selection of bulk material. A shaker conveyor consists of a heavy and (infinitely) stiff designed shaker and/or screening trough, which is supported by several pairs of guiding rocker arms. The rocker arms are also connected with the lower base frame which is anchored in the building foundation by means of tie bolts. The eccentric shaft transmitting the oscillations to the trough is always driven by elastic belt drive to compensate the hits by the dead centers of the crank shaft drive. A driving rod with an elastic drive head connects the crank drive with the base frame of the trough and transmits the required oscillations for the transport of the bulk material on the feeder. According to the length, stiffness and weight of the shaker trough several pairs of supporting and guiding rocker arms are required between base frame and conveyor.

Relatively **slow** acting oscillating conveyors are usually designed as positive movement systems ("brute-force" systems) transmitting the high reaction forces of the crank reverse motion into the building foundation. Faster running shaker conveyors with crank shaft drive are therefore usually designed as two mass systems with direct compensation of the reaction forces by the counter-mass hanging at the lower end of so said double rocker arms directly underneath the trough mass ("fast-runner" systems).

To achieve a very "smooth" course of motions on **fast** acting shaker conveyors based on one or two masses the installation of additional **spring accumulators** offering an actuation of the shaker system close by the resonance frequency ("natural frequency" systems) is recommended. These pre-loaded spring accumulators compensate the hard hits of the crank shaft drive at the dead centers and are heavily supporting the eccentric trough motion with their high dynamic stiffness.

One mass shaker conveyor systems without spring accumulators

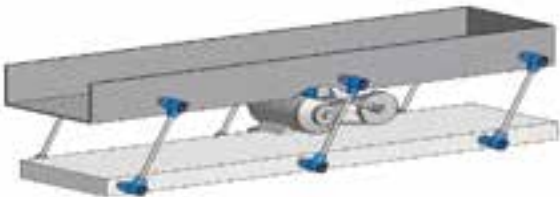
Design	Characteristics	ROSTA elements
 <p>"brute-force" system as basic version</p>	<p>acceleration: 1.1 to 1.7 g-forces</p> <p>conveying speed: 6 to 15 m/min</p> <p>trough lengths: max. 12 to 15 meters</p>	<p>oscillating mountings: AU, AS-P, AS-C, AR</p> <p>drive heads: ST</p>

The "brute-force" shaker conveyor system is widely used in the processing industries due to its constructive simplicity and cost efficient design method. It characterizes by a massive feeding trough mounted on several pairs of guiding rocker arms connected with a ground frame and driven by a crank shaft system. The relatively low costs for the design and construction of this feeding system are favouring this standard shaker for the use in many processing operations where rather low material speeds are fully adequate. Too high speeds and too long strokes would generate in this one mass system too high shocks by the change in direction of the crank shaft drive. Therefore, accelerations of >1,7 g-forces are not applicable with this "brute-force" shaker.

To avoid high material fatigue stress on the trough structure, the relevant design should feature heavy stiffening ribs and border strips to make the feeding channel more or less "infinitely" stiff. One mass shaker conveyors have to be bolted down on the foundations by means of tie anchors.

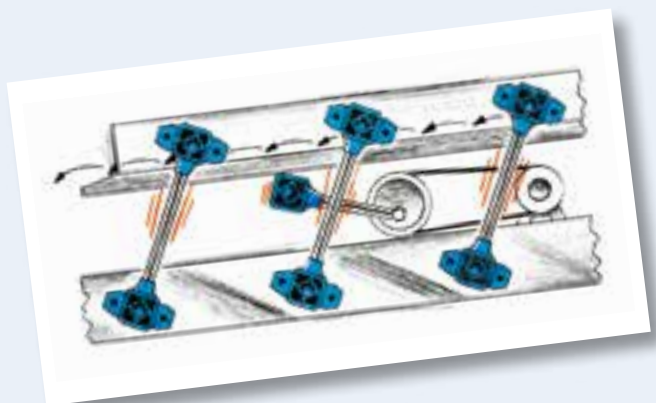

One mass shaker conveyor systems equipped with spring accumulators

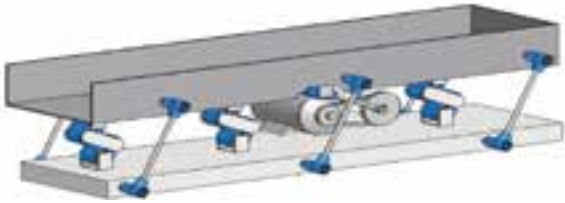
Design	Characteristics	ROSTA elements
 <p>"natural frequency" system offering smooth course</p>	<p>acceleration: 1.1 to 2.2 g-forces</p> <p>conveying speed: 6 to 22 m/min</p> <p>trough lengths: up to 20 meters</p>	<p>oscillating mountings: AU, AS-P, AS-C, AR</p> <p>drive heads: ST</p> <p>spring accumulators: DO-A elements</p>

These "natural frequency" feeding system generally shows the same constructive design like the "brute-force" shaker, but is disposed with additional spring accumulator sets installed between trough structure and ground frame in order to reduce the hard hits by the change in direction of the crank shaft drive. Furthermore, due to the high dynamic stiffness of the spring accumulator sets, the course of motions of the trough becomes harmonic, energy-saving and gentle avoiding material stress and early fatigue cracks on the structure. This system runs very silent due to the permanent, bidirectional spring action support at the stroke ends. The max. acceleration of this one mass system should not exceed 2.2 g-forces. The quantity and size of the required spring accumulators depends on the trough weight and the relevant rpm's of the crank shaft drive.

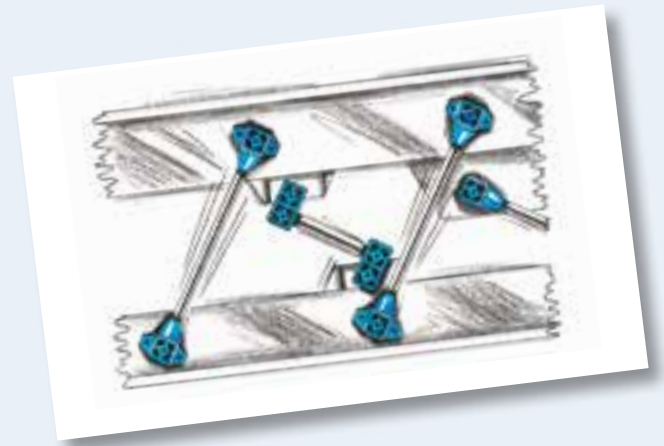

Two mass shaker conveyor systems with direct reaction force-compensation

Design	Characteristics	ROSTA elements
 <p>"fast-runner" system offering high capacities</p>	<p>acceleration: 1.5 to 5.0 g-forces</p> <p>conveying speed: 10 to 45 m/min</p> <p>trough lengths: up to 25 meters</p>	<p>oscillating mountings: AD-P, AD-C, AR</p> <p>drive heads: ST</p> <p>spring accumulators: additional DO-A elements</p>

This system is the "fast-runner" among the crank shaft driven shaker conveyors offering a very high material throughput. The lower counter-mass frame, directly connected with the feeding trough by means of ROSTA double rocker arms, fully compensates the resulting inertia forces of the mass 1 (trough) provided that its overall weight is identical with the trough weight. The upper shaker trough and also the counter-mass frame (or trough) offer a **procedural** field of applications. Both are feeding bulk material in the same direction; e.g. adding a sieve fraction in the upper trough bottom the small particles are sorted out and drop on the lower counter-mass or counter-trough being also shaken to the discharge-end of the machine.

For the most part, these two mass high-speed shaker conveyors are designed as smooth running "natural frequency" systems. Adding a quantitatively sufficient number of double rocker arms between trough, machine frame and counter-mass, the resulting

high dynamic stiffness of the elastic suspensions keeps the shaker machine running close to the natural frequency of the rocker arms. Otherwise, also by installing some additional DO-A spring accumulators between machine frame and trough or between machine frame and counter-mass a natural frequency acting of the system can be attained.

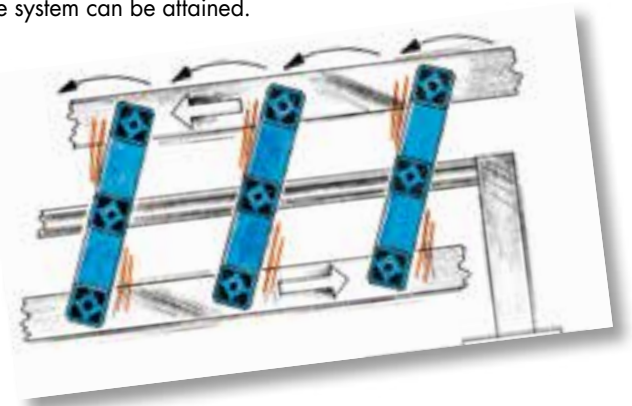

Technology

1. One mass systems without spring accumulators: Calculation



	Subject	Symbol	Example	Unit
Length, weight	Trough length	L	2.5	m
	Weight empty trough	m ₀	200	kg
	Weight of feeding material		50	kg
	Material coupling factor 50% *	m _m	25	kg
	Weight of oscillating mass *	m = m ₀ + m _m	225	kg
Drive parameter	Eccentric radius	R	12	mm
	Stroke	sw = 2 · R	24	mm
	Rpm on trough	n _s	340	min ⁻¹
	Gravity acceleration	g	9.81	m/s ²
	Oscillating machine factor	K	1.6	
	Acceleration	a = K · g	1.6	g
	Total spring value of system	c _t	285	N/mm
Rocker arms	Distance between rockers max.	L _{max}	1.5	m
	Quantity of rockers	z	6	
	Load per rocker	G	368	N
	Selection osc. elements (e. g.)		12x AU 27	
	Selection ROSTA-elements: AU, AR, AS-P, AS-C			
Drive	Center distance of elements	A	200	mm
	Acceleration force	F	3423	N
	Selection drive head		1x ST 45	
Spring value of natural frequency shaker	Drive capacity approx.	P	1.0	kW
	Dynamic torque	M _d	2.6	Nm/°
	Dynamic spring value per rocker	c _d	7.4	N/mm
	Dynamic spring value of all rockers	z · c _d	44.7	N/mm
	Resonant ability factor	i	0.16	

- * the following factors have to be considered by the definition of the material coupling:
- high coupling factor or sticking of wet and humid material
 - possible stemming of the trough

2. One mass system with spring accumulators: Calculation

Calculation analog chapter 1 with following additions:

Spring accumulators	Quantity	z _s	2	
	Dynamic spring value per item	c _s	100	N/mm
	Dynamic spring value of all items	z _s · c _s	200	N/mm
	Resonant ability factor	i _s	0.86	
	Selection of accumulators		2x cons. of 2x DO-A 45 x 80	



www.rosta.com

Calculation formulas

Oscillating machine factor

$$K = \frac{\left(\frac{2\pi}{60} \cdot n_s\right)^2 \cdot R}{g \cdot 1000} = \frac{n_s^2 \cdot R}{894'500} [-]$$

Total spring value of system

$$c_t = m \cdot \left(\frac{2\pi}{60} \cdot n_s\right)^2 \cdot 0.001 [N/mm]$$

Minimum quantity of rockers

$$z = \left(\frac{L}{L_{max}} + 1\right) \cdot 2 [-]$$

Load per rocker

$$G = \frac{m \cdot g}{z} [N]$$

Acceleration force (ST selection)

$$F = m \cdot R \cdot \left(\frac{2\pi}{60} \cdot n_s\right)^2 \cdot 0.001 = c_t \cdot R [N]$$

Drive capacity approx.

$$P = \frac{F \cdot R \cdot n_s}{9550 \cdot 1000 \cdot \sqrt{2}} [kW]$$

Dynamic spring value per rocker

$$c_d = \frac{M_{d, 360} \cdot 1000}{A^2 \cdot \pi} [N/mm]$$

Resonant ability factor

$$i = \frac{z \cdot c_d}{c_t} [-]$$

By a resonant ability factor $i \geq 0,8$ the system is usually titled "natural frequency shaker".

Resonant ability factor with accumulators

$$i_s = \frac{z \cdot c_d + z_s \cdot c_s}{c_t} [-]$$

By a resonant ability factor $i_s \geq 0.8$ the system is usually titled "natural frequency shaker".

Technology

3. One mass shaker conveyor systems: Installation instructions

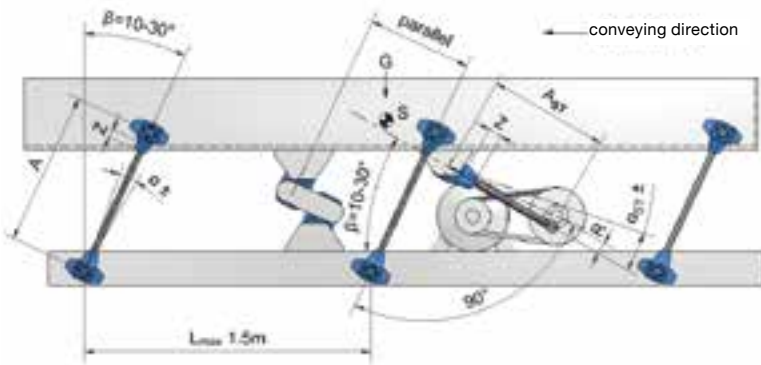

Distance between rockers L_{max} :

- Usually, the distance between the rocker arms on the trough along-side is up to 1.5 meters, depending on the stiffness of the trough.
- By trough widths >1.5 m we do recommend to provide the trough bottom side with a third, central row of rocker arms for stability reasons.

Mounting position drive head ST:

For one mass shaker systems it is recommendable to position the drive head slightly ahead of the center of gravity of the trough, towards the discharge end.

Rocker mounting angle β :

According to the relevant processing function of the shaker conveyor, the rocker arms are positioned at mounting angles between 10° to 30° in relation to the perpendicular line. (The ideal combination of fast conveying speed with high material throw is given by a rocker inclination angle of 30° .) The power input position of the drive-rod from the eccentric drive should stay at right angles to the rocker arms, this orthogonal positioning offers a harmonic course of the drive system.

Angle of oscillation α :

The machine parameters, angle of oscillation and revolutions should be determined in the admissible area of operations (see chapter 5).

Screw quality:

The screw quality should be grade 8.8 secured by the required tightening moment.

Depth of thread engagement Z:

The depth of engagement should be at least $1.5 \times$ the thread nominal width.

4. Average material speed on shakers v_m

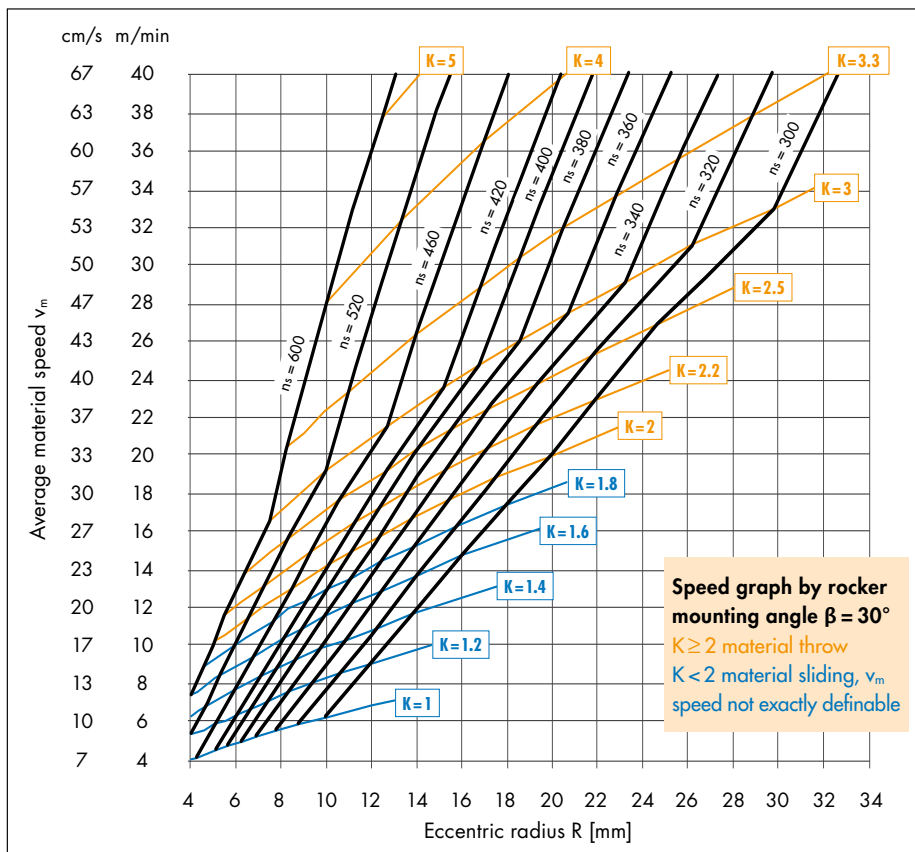

Main influence factors

- layer height of material
- property trough bottom (slip-resistance)
- mounting angle β of the rockers
- feeding capability of the material depending on size, form and humidity of the grains, e.g. very dry and fine grained material is submitted to slippage factors up to 30%.

Example: One mass system with eccentric drive

Out of the intersection point $R = 12$ mm and the revolutions $n_s = 340$ min^{-1} is resulting a theoretical material speed of $v_m = 12$ m/min or 20 cm/sec.

By acceleration factors $K > 2$ and rocker mounting angles of $\beta = 30^\circ$ (to the perpendicular line) the vertical acceleration is getting bigger than $1g$, therefore the material starts lifting from the trough bottom = material throw.

Technology

5. Maximum rocker load G , revolutions n_s and angle of oscillation α

Size (e.g. AU 15)	max. load capacity per rocker [N]				max. revolutions n_s [min ⁻¹]*	
	K < 2	K = 2	K = 3	K = 4	$\alpha \pm 5^\circ$	$\alpha \pm 6^\circ$
15	100	75	60	50	640	480
18	200	150	120	100	600	450
27	400	300	240	200	560	420
38	800	600	500	400	530	390
45	1'600	1'200	1'000	800	500	360
50	2'500	1'800	1'500	1'200	470	340
60	5'000	3'600	3'000	2'400	440	320

The angle of oscillation α of each oscillating component (rockers accumulators and drive head) has to be settled within the permissible range (n_s and α).

Calculation oscillation angle for rockers

Eccentric radius R [mm]
Center distance A [mm]
Oscillation angle $\alpha \pm [^\circ]$

$$\alpha = \arctan\left(\frac{R}{A}\right) [^\circ]$$

Please contact ROSTA for the permissible load indications by higher accelerations and for rocker elements offering higher load capacities. Usually are the revolutions n_s between 300 to 600 min⁻¹ and the oscillation angles max. $\pm 6^\circ$.

* basics: "permissible frequencies" in the Technology part of the ROSTA catalogue.

6. Two mass shaker systems with direct reaction force-compensation

- Maximum acceleration forces of approx. 5 g, shaker lengths up to 25 meters
- Equipped with ROSTA double rockers **AD-P**, **AD-C** and/or made out of **AR** elements
- Ideal compensation when $m_1 = m_2$
- Element selection analogue chapter 1, but with load of the two masses:
Actuated mass (+ material coupling of feeding mass) m_1 [kg]
Driven mass (+ material coupling of feeding mass) m_2 [kg]
Total oscillating mass $m = m_1 + m_2$ [kg]

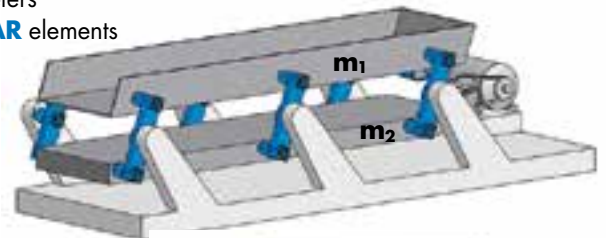

Dynamic spring value c_d per double rocker $c_d = \frac{3 \cdot M_d \cdot 360 \cdot 1000}{2 \cdot A^2 \cdot \pi}$ [N/mm]

- Calculation of c_i and F based on the total mass (m_1 and m_2)
- Power input from eccentric drive with **ST arbitrary** on m_1 or m_2 at **any point** alongside m_1 or m_2
- On demand, special double rocker arms with varying center distances A are available as "customized rockers"

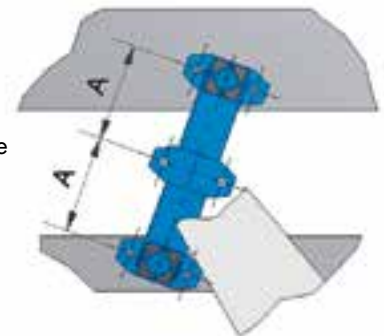

The 9 installation steps for a two mass system with double rocker arms:

1. All fixation holes for the rockers in trough, counter-mass and machine frame have to be drilled very accurately previous the final machine assembling.
2. Installation of the middle elements of the rocker arms on the central machine frame, all inclination angles duly adjusted (e.g. 30°), tightening of the screws with required fastening torque.
3. Lifting of the counter-mass with accurate horizontal alignment until the bores in the counter-mass frame stay congruent with the bore holes of the lower element. Jamming of the counter-mass with e.g. wooden chocks.
4. Tightening of the fixation screws on counter-mass with required fastening torque.
5. Inserting of the feeding trough into machine frame structure. Accurate horizontal alignment until the bores in the trough stay congruent with the bore holes of the upper element. Jamming of the trough with e.g. wooden chocks.
6. Tightening of the fixation screws on trough with required fastening torque.
7. Installation of the driving rod with drive head ST in "neutral" position i.e. eccentric drive should stay in between the two stroke ends. Length adjustment of the driving rod and tightening of the counternuts.
8. Removal of the jamming chocks under counter-mass and trough.
9. Test start of the shaker conveyor.