

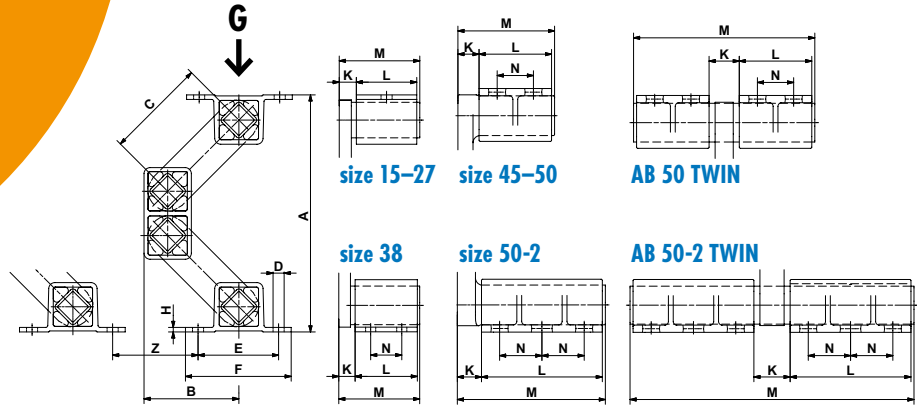

Oscillating Mountings

Type AB (standard blue)

Type ABI (stainless steel)



Oscillating Mountings

| Art. No. | Type | Load capacity Gmin. – Gmax. [N] | A un- loaded | A* max. load | B un- loaded | B* max. load | C | D | E | F | H | K | L | M | N | Weight [kg] |
|------------|--------------|---------------------------------------|--------------------|--------------------|--------------------|--------------------|-----|-------|-----|-----|-----|----|-----|-----|----|----------------|
| 07 051 056 | AB 15 | 50 – 160 | 168 | 114 | 70 | 88 | 80 | ∅7 | 50 | 65 | 3 | 10 | 40 | 52 | - | 0.5 |
| 07 171 107 | ABI 15 | 70 – 180 | | | | | | 7x10 | | | | | | | | 0.9 |
| 07 051 057 | AB 18 | 120 – 350 | 208 | 146 | 88 | 109 | 100 | ∅9 | 60 | 80 | 3.5 | 14 | 50 | 67 | - | 1.2 |
| 07 171 114 | ABI 18 | | | | | | | 9x15 | | | | | | | | 1.7 |
| 07 051 058 | AB 27 | 250 – 800 | 235 | 170 | 94 | 116 | 100 | ∅11 | 80 | 105 | 4.5 | 17 | 60 | 80 | - | 2.2 |
| 07 171 109 | ABI 27 | | | | | | | 11x20 | | | | | | | | 3.3 |
| 07 051 059 | AB 38 | 600 – 1'600 | 305 | 225 | 120 | 147 | 125 | ∅13 | 100 | 125 | 6 | 21 | 80 | 104 | 40 | 5.1 |
| 07 171 110 | ABI 38 | | | | | | | 13x20 | | | | | | | | 7.6 |
| 07 051 054 | AB 45 | 1'200 – 3'000 | 353 | 257 | 141 | 172 | 140 | 13x26 | 115 | 145 | 8 | 28 | 100 | 132 | 58 | 11.5 |
| 07 171 111 | ABI 45 | | | | 137 | 168 | | | | | | | | | | 13.5 |
| 07 051 061 | AB 50 | 2'500 – 6'000 | 380 | 277 | 150 | 184 | 150 | 17x27 | 130 | 170 | 12 | 35 | 120 | 160 | 60 | 19.1 |
| 07 171 112 | ABI 50 | | | | | | | | | | | | | | | 21.9 |
| 07 051 055 | AB 50-2 | 4'200 – 10'000 | 380 | 277 | 150 | 184 | 150 | 17x27 | 130 | 170 | 12 | 40 | 200 | 245 | 70 | 32.2 |
| 07 171 113 | ABI 50-2 | | | | | | | | | | | | | | | 35.4 |
| 07 051 008 | AB 50 TWIN | 5'000 – 12'000 | 380 | 277 | 150 | 184 | 150 | 17x27 | 130 | 170 | 12 | 50 | 120 | 300 | 60 | 35.0 |
| 07 051 009 | AB 50-2 TWIN | 8'400 – 20'000 | 380 | 277 | 150 | 184 | 150 | 17x27 | 130 | 170 | 12 | 60 | 200 | 470 | 70 | 54.0 |

| Art. No. | Type | Natural frequency Gmin. – Gmax. [Hz] | Z | Dynamic spring value | | Capacity limits by different rpm | | | | | | Light metal profile | Steel welded construction | Nodular cast iron | ROSTA blue painted | Stainless steel casing |
|------------|--------------|--|-----|-----------------------|-------------------------|--|---------------|--|---------------|---|---------------|---------------------|---------------------------|-------------------|--------------------|------------------------|
| | | | | cd vertical [N/mm] | cd horizontal [N/mm] | 720 min ⁻¹ sw max. [mm] | K max. [-] | 960 min ⁻¹ sw max. [mm] | K max. [-] | 1440 min ⁻¹ sw max. [mm] | K max. [-] | | | | | |
| 07 051 056 | AB 15 | 4.0 – 2.8 | 65 | 10 | 6 | 14 | 4.1 | 12 | 6.2 | 8 | 9.3 | x | x | x | | |
| 07 171 107 | ABI 15 | | | | | | | | | | | | | | | x |
| 07 051 057 | AB 18 | 3.7 – 2.6 | 80 | 20 | 14 | 17 | 4.9 | 15 | 7.7 | 8 | 9.3 | x | x | x | | |
| 07 171 114 | ABI 18 | | | | | | | | | | | | | | | x |
| 07 051 058 | AB 27 | 3.7 – 2.7 | 80 | 40 | 25 | 17 | 4.9 | 14 | 7.2 | 8 | 9.3 | x | x | x | | |
| 07 171 109 | ABI 27 | | | | | | | | | | | | | | | x |
| 07 051 059 | AB 38 | 3.0 – 2.4 | 100 | 60 | 30 | 20 | 5.8 | 17 | 8.8 | 8 | 9.3 | x | x | x | | |
| 07 171 110 | ABI 38 | | | | | | | | | | | | | | | x |
| 07 051 054 | AB 45 | 2.8 – 2.3 | 115 | 100 | 50 | 21 | 6.1 | 18 | 9.3 | 8 | 9.3 | x | x | x | x | |
| 07 171 111 | ABI 45 | | | | | | | | | | | | | | | x |
| 07 051 061 | AB 50 | 2.4 – 2.1 | 140 | 190 | 85 | 22 | 6.4 | 18 | 9.3 | 8 | 9.3 | | | x | x | |
| 07 171 112 | ABI 50 | | | | | | | | | | | | | | | x |
| 07 051 055 | AB 50-2 | 2.4 – 2.1 | 140 | 320 | 140 | 22 | 6.4 | 18 | 9.3 | 8 | 9.3 | | | x | x | |
| 07 171 113 | ABI 50-2 | | | | | | | | | | | | | | | x |
| 07 051 008 | AB 50 TWIN | 2.4 – 2.1 | 140 | 380 | 170 | 22 | 6.4 | 18 | 9.3 | 8 | 9.3 | x | x | x | | |
| 07 051 009 | AB 50-2 TWIN | 2.4 – 2.1 | 140 | 380 | 170 | 22 | 6.4 | 18 | 9.3 | 8 | 9.3 | x | x | x | | |

Values in nominal load range at 960 min⁻¹ and sw of 8 mm
Acceleration > 9.3 g is not recommended







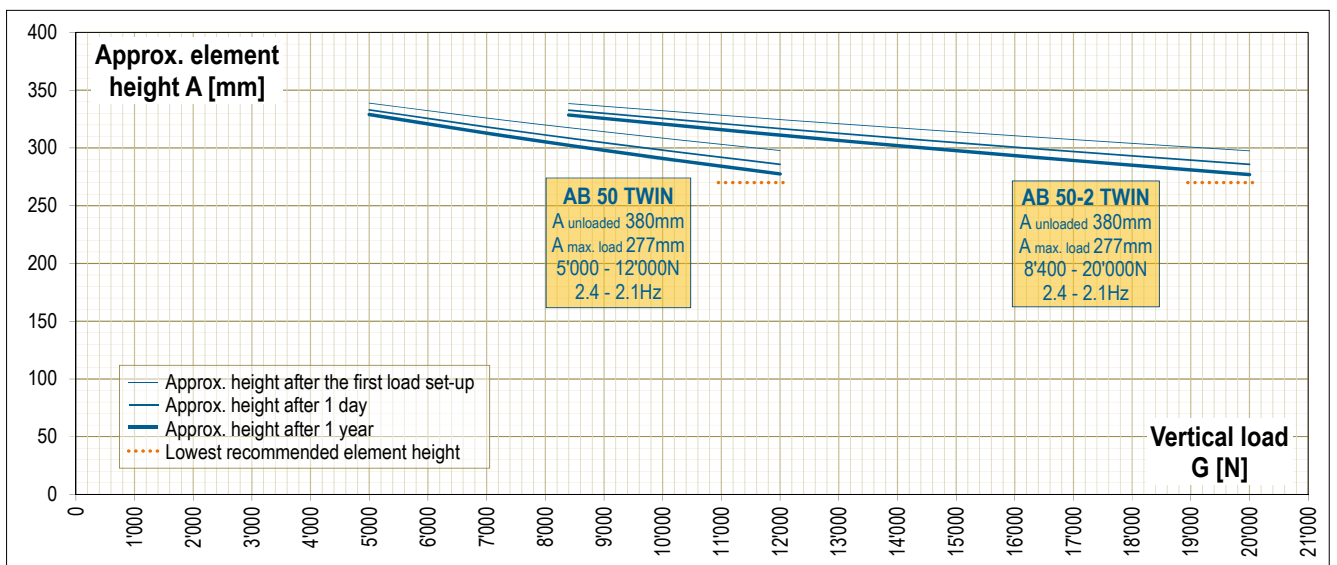
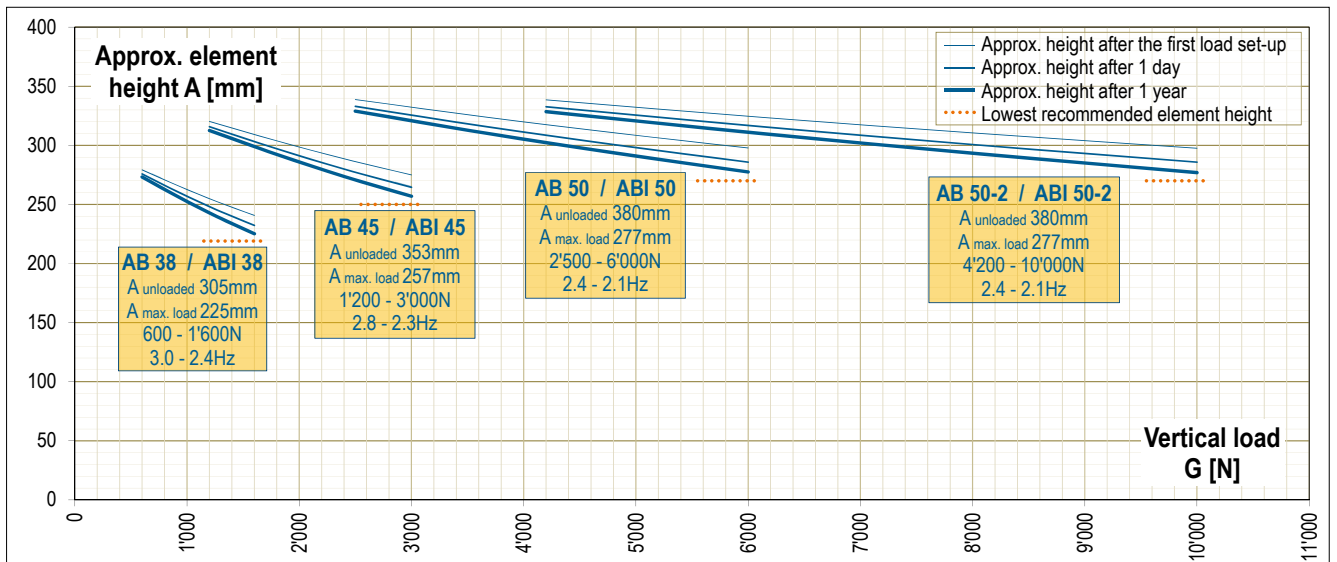
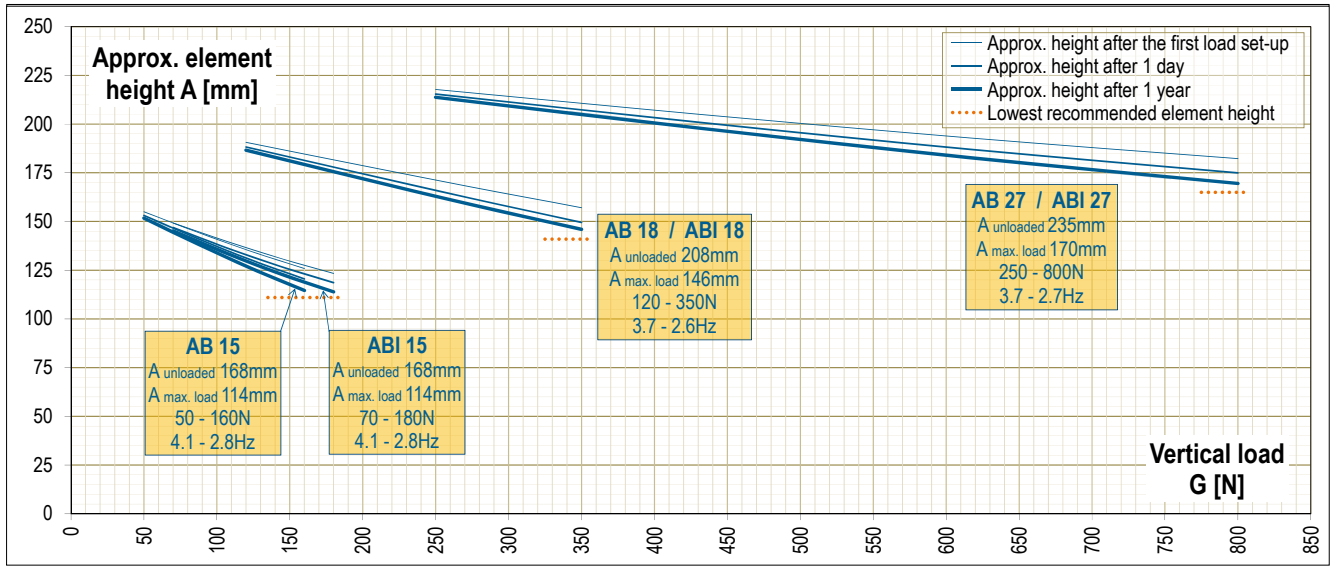

Material structure

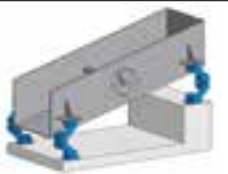
* compression load Gmax. and cold flow compensation (after approx. 1 year).





Element heights and cold flow behaviour AB and ABI



Selection table for free oscillating systems (with unbalanced excitation)

| | |  |  |  |  |
|---|---|---|--|--|---|
| | | One mass system circular motion screen | One mass system linear motion screen | Two mass system with counterframe | One mass system linear motion screen hanging |
|  | AB ABI Page 2.10 | Oscillating Mounting – universal mounting. High vibration isolation and low residual force transmission. Natural frequencies approx. 2–3 Hz. 9 sizes from 50 N to 20'000 N per element. | | | |
|  | AB-HD ABI-HD Page 2.12 | Oscillating Mounting for impact loading and high production peaks. (Heavy Duty) Natural frequencies approx. 2.5–4 Hz. 8 sizes from 150 N to 14'000 N per element. | | | |
|  | AB-D Page 2.14 | | Oscillating Mounting in compact design. Optimal in two mass systems as counterframe mounting. Natural frequencies approx. 3–4.5 Hz. 7 sizes from 500 N to 16'000 N per AB-D. | | |
|  | HS Page 2.15 | | | | Oscillating Mounting for hanging systems. Natural frequencies approx. 3–4 Hz. 5 sizes from 500 N to 14'000 N per HS. |

Selection table for gyratory sifters

| | | | | |
|---|---------------------------|---|--|---|
|  | AK Page 2.36 | Universal Joint for the support or suspension of positive drive or freely oscillating gyratory sifting machines. 10 sizes up to 40'000 N per AK. | Gyratory sifter upright staying | Gyratory sifter hanging |
|  | AV Page 2.38 | Single Joint specially designed with large rubber volume for the suspension of gyratory sifting machines. Models with right-hand and left-hand threads. 5 sizes up to 16'000 N per AV. |  |  |

Technology of free oscillating systems with unbalanced excitation

Introduction

Free oscillating systems are either activated in using exciters, unbalanced motors or unbalanced shafts.

The oscillation amplitude, type of vibration and the direction of vibration of the screen are determined by the dimensioning and arrangement of these actuators. The excitation force, the angle of inclination of the excitation, the inclination of the screen-box and the position of the center of gravity determine the resulting oscillation amplitude of the device. The oscillation amplitude, and thereby the conveying speed of the machine, can be optimized by augmenting these.

ROSTA spring suspensions support the desired oscillation movement of the screen machine. Through their shape and function, they help to achieve a purely linear conveyor motion without unwanted lateral tumbling.

These ideal spring suspensions harmonically support the running of the vibrating screen. Because of their high spring deflection capacity, they offer a good detuning of the excitation frequency with a very low natural frequency, which guarantees a high isolation effect with regard to the machine substructure. The ROSTA mounts effectively dissipate the large residual force peaks at start-up and shut-down, when passing through the natural frequency of the suspension.



Circular motion screens



Circular motion screens or circular vibrators are normally excited by unbalanced weights that create a circular rotating oscillation of the screening frame. Relatively low accelerations of the screened material are achieved with this form of excitement. Circular vibrators thereby normally work with a screening frame inclination of 15° to 30° , so that an adequate material throughput is ensured.

It is recommended to mount circular vibratory screens of this kind on ROSTA type AB or AB-HD oscillating mountings. Experience has shown that the positioning of the AB suspensions under circular vibrators should be a mirror-inverted of each other, which, with the above-mentioned frame inclination, will counteract the tendency of the shifting of the center of gravity. If the suspension of the screening frame requires two supporting suspensions per brace support for reasons of capacity, these should also be preferably arranged in mirror-inverted manner for the above-mentioned reason.

Linear motion screens

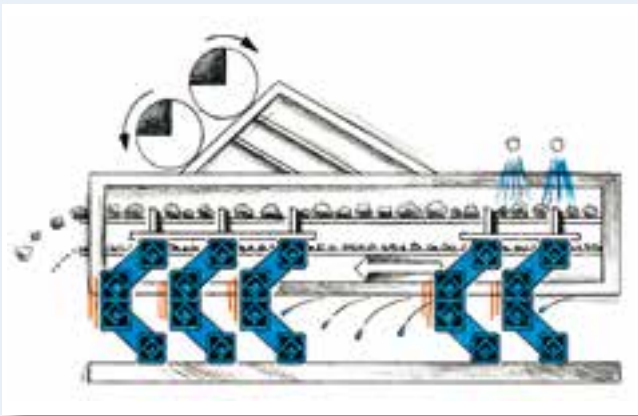

Linear motion screens or linear vibrators are normally excited by two unbalanced motors or by means of linear exciters, as well as through double unbalanced shafts (Eliptex), which generate a linear or slightly elliptical oscillation of the screening frame. Depending on the inclination positioning of the exciter, the angle of throw of the screened product can be adapted to the desired form of processing. A very high acceleration of the screened product, i.e. a higher material throughput, is achieved with linear vibrating screens. The screening frame of the linear vibrator is normally in the horizontal position.

Linear vibrating screens are preferably mounted on ROSTA oscillating mountings type AB or AB-HD. Depending on the positioning of the exciter on the screening frame, the feed-end: discharge-end load distribution can be different. The feed-end side is normally lighter, as the exciters are positioned close to the discharge-end and thereby pull the material through the screening frame; in many cases, the feed-end: discharge-end distribution is thereby 40% to 60%. In the interest of an even suspension, it is thereby recommended to mount the screening frame on six or more ROSTA oscillating mountings. All oscillating mountings should stand in the same direction, with the "knee" pointing in the discharge-end direction.

Linear motion screens with counterframe

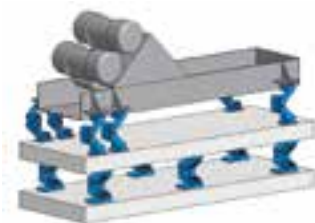

If, due to the demands of the process, large screens are mounted at a very high position in a building or in a purely steel construction, the transmission of the residual forces of a single-mass machine can set the

entire structure into unwanted vibrations. Or if a new and more powerful machine is mounted in an existing building, the residual force transmission could be too high for the older building. The residual force transmission is drastically reduced through the mounting of a counterframe under the screen, with only a negligible loss of oscillation amplitude (compensation movement of the counterframe reduces the oscillation amplitude).

ROSTA also has the ideal supports for the suspension of counterframes, the very compact mountings type AB-D.

Discharge chutes hanging under silos and bunkers

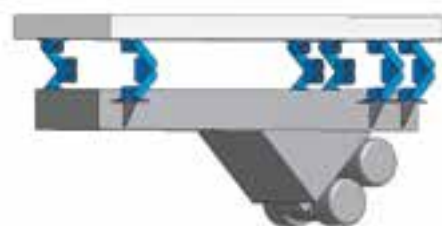

Discharge chutes under silos are normally supported by means of complicated yoke constructions and are suspended on pressure springs. With its HS suspensions (HS = hanging screen), ROSTA offers the possibility of the direct, cost-effective suspension of the discharge unit on silos and bunkers. The geometry of the HS suspensions has been designed to accommodate tensile loads.

Technology

Design layout and evaluation

| Subject | Symbol | • Example | Unit |
|--|----------------------------|-----------------|------------------|
| Mass of the empty channel and drive | m_0 | 680 | kg |
| Products on the channel | | 200 | kg |
| of which approx. 50% coupling* | | 100 | kg |
| Total vibrating mass* | m | 780 | kg |
| Mass distribution: feed end | % feed end | 33 | % |
| discharge end | % discharge end | 67 | % |
| Acceleration due to gravity | g | 9.81 | m/s ² |
| Load per corner feed end | $F_{\text{feed end}}$ | 1263 | N |
| Load per corner discharge end | $F_{\text{discharge end}}$ | 2563 | N |
| • Element choice in example | | 6x AB 38 | |
| Working torque of both drives | AM | 600 | kgcm |
| Oscillating stroke empty channel | sw_0 | 8.8 | mm |
| Oscillating stroke in operation | sw | 7.7 | mm |
| Motor revolutions | n_s | 960 | rpm |
| Centrifugal force of both drives | F_z | 30'319 | N |
| Oscillating machine factor | K | 4.0 | |
| Machine acceleration | $a = K \cdot g$ | 4.0 | g |
| • Natural frequency suspensions | | fe | 2.7 Hz |
| Degree of isolation | W | 97 | % |

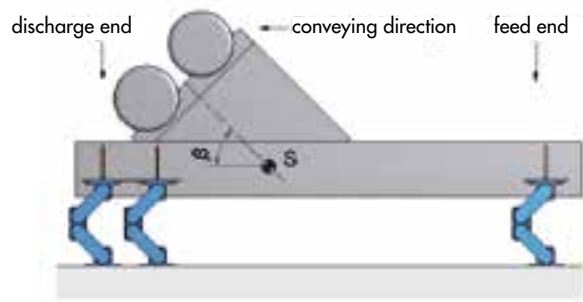

Calculation formulas

Loading per corner

$$F_{\text{feed-end}} = \frac{m \cdot g \cdot \% \text{ feed-end}}{2 \cdot 100} \quad F_{\text{discharge-end}} = \frac{m \cdot g \cdot \% \text{ discharge-end}}{2 \cdot 100} \quad [N]$$

Oscillating stroke (Amplitude peak to peak)

$$sw_0 = \frac{AM}{m_0} \cdot 10 \quad sw = \frac{AM}{m} \cdot 10 \quad [mm]$$

Centrifugal force

$$F_z = \frac{\left(\frac{2\pi}{60} \cdot n_s\right)^2 \cdot AM \cdot 10}{2 \cdot 1000} = \frac{n_s^2 \cdot AM}{18'240} \quad [N]$$

Oscillating machine factor

$$K = \frac{\left(\frac{2\pi}{60} \cdot n_s\right)^2 \cdot sw}{2 \cdot g \cdot 1000} = \frac{n_s^2 \cdot sw}{1'789'000} \quad [-]$$

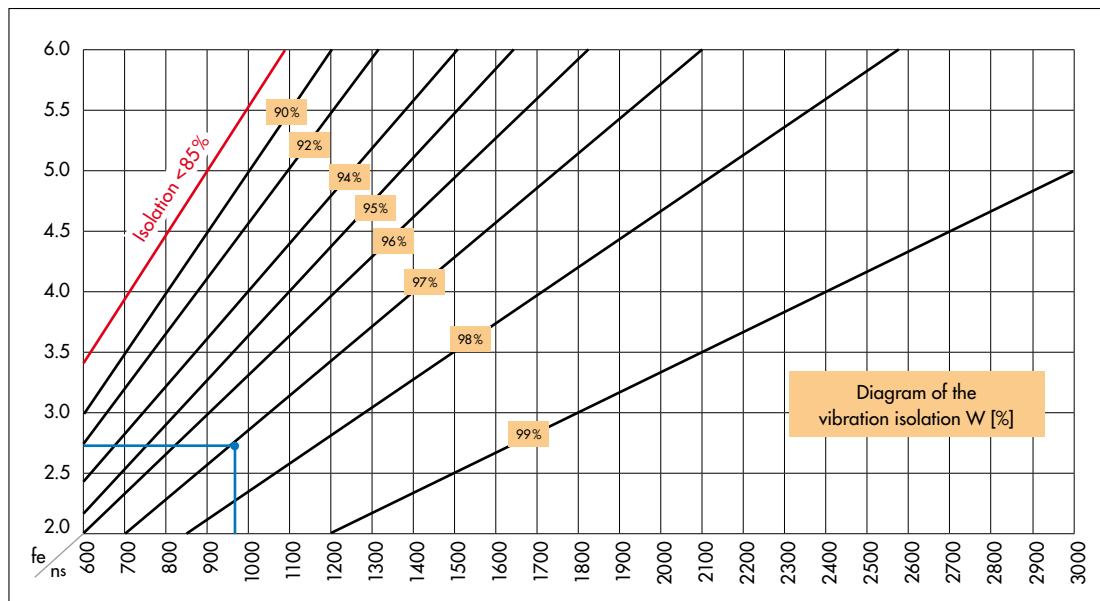

Vibration isolation

$$W = 100 - \frac{100}{\left(\frac{n_s}{60 \cdot fe}\right)^2 - 1} \quad [%]$$

• Example:

The proportion of the relationship between exciter frequency 16 Hz (960 rpm) and mount frequency 2.7 Hz is offering a degree of isolation of 97%.

* The following has to be observed for the determination of the coupling effect and material flow:

- High coupling or sticking of humid bulk material
- Channel running full
- Fully stacked screen deck with humid material
- Weight distribution with and without conveyed material
- Centrifugal force does not run through the center of gravity (channel full or empty)
- Sudden impact loading occurs
- Subsequent additions to the screen structure (e.g. additional screening deck)

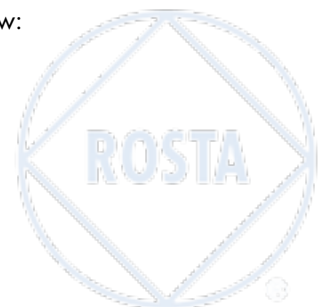

Technology

Determination of the average material conveying speed v_m

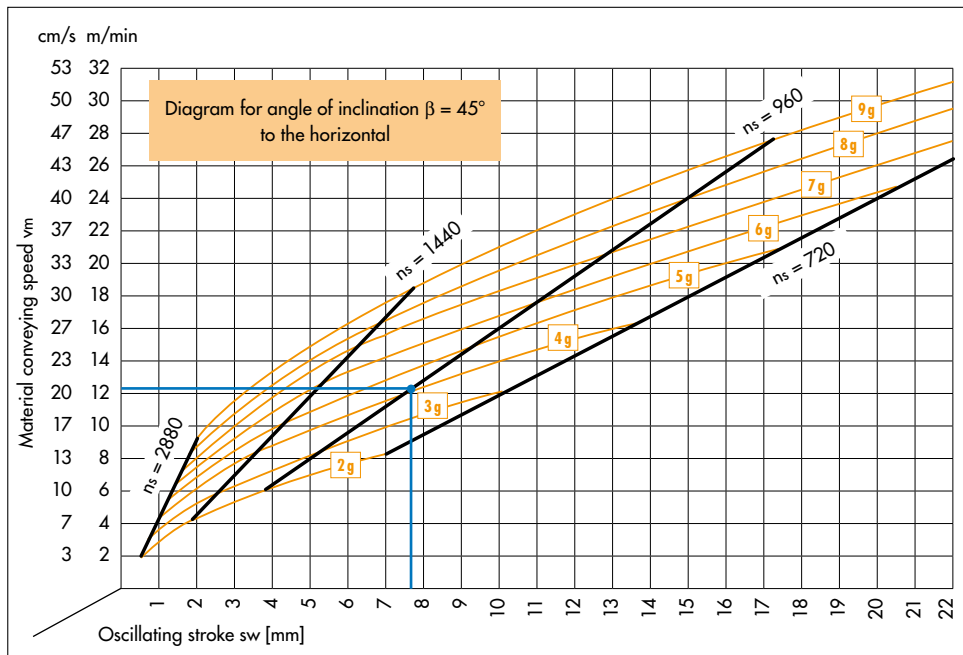

Main influencing factors:

- Conveying ability of the material
- Height of the bulk goods
- Screen box inclination
- Position of unbalanced motors
- Position of the center of gravity

The material speed on circular motion screens does vary, due to differing screen-box inclination angles.

• Example:

The horizontal line out of the intercept point of stroke (7.7 mm) and motor revolutions (960 rpm) is indicating an average theoretical speed of 12.3 m/min or 20.5 cm/sec.

Resonance amplification and continuous running

At the screen start-up and run-out the suspension elements are passing through the resonance frequency. By the resulting amplitude superelevation the four rubber suspensions in the AB mountings do generate a high level of damping which is absorbing the remaining energy after only a few strokes. The screen box stops its motion within seconds.

Laboratory measurements of a typical development of the residual forces on a ROSTA screen suspension:

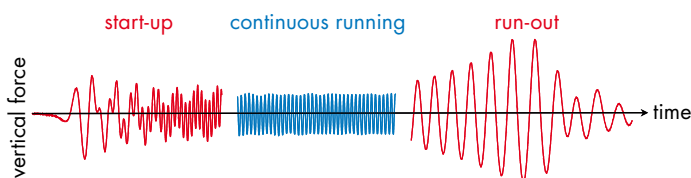

Alignment of the elements

If the suspensions for linear motion screens are arranged as shown on page 2.7, a harmonic, noiseless oscillation of the screen will result. The rocker arm fixed to the screen carries out the greater part of the oscillations. The rocker arm fixed to the substructure remains virtually stationary and ensures a low natural frequency, and thereby also a good vibration isolation. The mounting axis has to be arranged to be at right angles (90°) to the conveying axis, with maximum tolerance of $\pm 1^\circ$.

